

Area Weight Balance

EAR Series

Model EAR-300

Instruction Manual



Contents

1	Warranty and Liability	3
1.1	Notices within the Operating Instructions	3
1.2	Responsibilities of the Operating Company	3
1.3	Responsibilities of the Personnel	3
1.4	Informal Safety Measures	4
1.5	Training of the Personnel	4
1.6	Intended Use	4
1.7	Dangers in Handling the Device	4
1.8	Copyright	4
1.9	Declaration of Conformity, RoHS II and WEEE Registration	4
2	Specifications	5
2.1	Delivery Includes	5
2.2	Unpacking and Assembly	5
3	Initial Setup and Operating Procedure	6
3.0	Notices Before Starting Measurement	6
3.1	Operating Elements	6
3.1.1	Display Details	6
3.1.2	Aligning the Instrument	7
3.2	Connecting the AC Adapter	7
3.2.1	Switch-On	7
3.2.2	Switch-Off	7
3.3	Settings	8
3.3.1	Function Settings	8
3.3.2	Measuring Mode Selection	10
3.3.3	Zero Setting (ZERO)	10
3.4	Measuring Procedure	10
3.4.1	Standard Measuring Procedure	10
3.4.2	Measuring Procedure with Container (tare subtractive weighing)	11
3.4.3	Error Messages	12
3.5	Calibration of the Instrument	12
4	Service and Maintenance	14
5	Cleaning	14
6	Correspondence	14
7	Repairs	14

1 Warranty and Liability

In principle, the supply of the device is subject to our "General Conditions of Sale and Delivery." These have been provided to the operating company on conclusion of the contract, at the latest.

Warranty:

- SCHMIDT area weight balances are warranted for 12 months.

Parts subject to wear, electronic components and measuring springs are not covered by the warranty. No warranty or liability will be accepted for bodily injury or property damage resulting from one or several of the following causes:

- Misuse or abuse of the device.
- Improper mounting, commissioning, operation and maintenance of the device (e.g. verification interval).
- Operation of the device if any safeguards are defective or if any safety and protection precautions are not properly installed or not operative.
- Failure to comply with the notices in the Operating Instructions regarding transport, storage, mounting, commissioning, operation, maintenance and setup of the device.
- Any unauthorized structural alteration of the device.
- Insufficient inspection of device components that are subject to wear.
- Opening the device or improper repair work.
- Disasters caused by the effects of foreign objects or by force majeure.

1.1 Notices within the Operating Instructions

The fundamental prerequisite for the safe handling of this device and its troublefree operation is the knowledge of the basic safety notices and safety instructions.

These Operating Instructions contain the most important notices for the safe operation of the device.

These Operating Instructions, in particular the safety notices, must be observed by any person who works with the device. In addition, the local valid rules and regulations for the prevention of accidents must be complied with.

The representations within the Operating Instructions are not true to scale.

The dimensions given are not binding.

General indications of direction, such as FRONT, REAR, RIGHT, LEFT apply when viewing the front of the device.

1.2 Responsibilities of the Operating Company

In compliance with the EC Directive 89/655/EEC, the operating company agrees to only permit persons to work with the device who:

- are familiar with the basic regulations on industrial safety and accident prevention and who have been trained in handling the device.
- have read and understood the chapter on safety and the warning notices in these Operating Instructions and have confirmed this with their signatures.
- are examined regularly on their safe and conscientious working method.

1.3 Responsibilities of the Personnel

All persons who work with the device agree to perform the following duties before starting work:

- to observe the basic regulations on industrial safety and accident prevention.
- to read the chapter on safety and the warning notices in these Operating Instructions and to confirm with their signatures that they have understood them.

1.4 Informal Safety Measures

The Operating Instructions must always be kept on hand where the device is operated. Apart from the Operating Instructions, the general and local valid regulations on accident prevention and environmental protection must be provided and complied with.

1.5 Training of the Personnel

Only trained and instructed personnel is permitted to work with the device. The responsibilities of the personnel must be clearly defined for mounting, commissioning, operation, setup, maintenance, and repair. Trainees may only work with the device under the supervision of experienced personnel.

1.6 Intended Use

The device is intended exclusively to be used as a balance. Any other use or any use exceeding this intention will be regarded as misuse. Under no circumstances shall HANS SCHMIDT & Co GmbH be held liable for damage resulting from misuse.

The intended use also includes:

- Complying with all notices included in the Operating Instructions and observing all inspection and maintenance works.

1.7 Dangers in Handling the Device

The device was designed according to the state of the art and the approved safety standards. Nevertheless, its use may cause serious or fatal injury to the user or third persons, and/or an impairment of the device or of other material assets.

The device may only be applied:

- For its intended use in a faultless condition with regard to the safety requirements.
- Malfunctions that could impair safety must be remedied immediately.
- Personal protective equipment must be used according to the EC Directive 89/686/EEC.



The device must not be operated in potential explosive areas and must not come into contact with aggressive substances.

1.8 Copyright

The copyright on these Operating Instructions remains with the company HANS SCHMIDT & Co GmbH.

These Operating Instructions are intended for the operating company and its personnel only. They contain instructions and notices that may only be reproduced on the prior written permission of

HANS SCHMIDT & Co GmbH

and under indication of the complete reference data.

Violations will be prosecuted.

1.9 Declaration of Conformity, RoHs II and WEEE Registration

In compliance with the EU Directives 2014/30/EU and 2011/65/EU



HANS SCHMIDT & CO GmbH is registered in compliance with the German Electrical and Electronic Equipment Act (ElektroG) under WEEE Reg. No. DE 48092317.

2 Specifications

Capacity (weight mode):	300 g
Capacity (area weight mode):	30 000 g/m ²
Sample size:	100 cm ²
Resolution (weight mode):	0.01 g
Resolution (area weight mode):	1g/m ²
Accuracy (weight mode):	± 0.01 g
Accuracy (area weight mode):	± 1 g/m ²
Platform size (mm):	120 ø
Power supply:	Rechargeable battery DC 9 V/500 mA 12 h continuous use, 10 h charging time
AC adapter:	100 - 240 V AC - 50/60 Hz
Temperature range:	15 - 40° C
Air humidity:	85% RH, max.
Weight (net / gross):	Approx. 1.7 kg / 2.7 kg
Dimensions (mm):	211 L x 185 W x 59 H

2.1 Delivery Includes

Balance
1 AC adapter, 100 - 240 V
1 Calibration weight 200 g
1 Operating Instructions
Test certificate not available.

2.2 Unpacking and Assembly

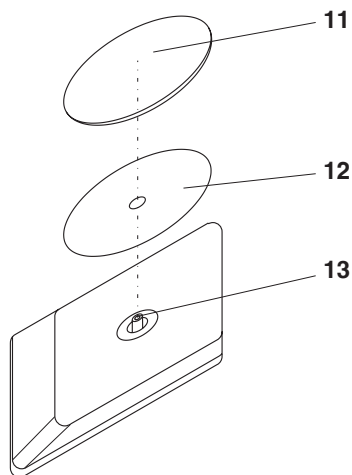

- Unpack the EAR-300.
- Inspect the EAR-300 for any shipping damage. Should you find any damage, immediately notify the vendor. Notices of defect must be filed immediately, in writing, at the latest within 7 days on receipt of the goods.

Assembly:

- Remove the rubber cap from the weighing shaft
- Carefully press the support plate **12** onto the weighing shaft **13**.
- Mount the support plate with the hexagon socket screw by using the hex-wrench with max. 0.2 Nm.
- Place the sample platform **11** on the support plate.

Removal:

- To remove the sample platform **11** and the support plate **12** proceed in the reverse order.



The support plate must be removed for transport to avoid damage of the balance.

3 Initial Setup and Operating Procedure

3.0 Notices Before Starting Measurement

Have you read and understood the Operating Instructions, in particular Chapter 1 “Basic Safety Notices”? You are not permitted to operate the device before doing so. Before working with the device you must put on your personal protective clothing, if necessary. For example, eye protectors, gloves, etc. The ID plate with the serial number is provided on the back side of the instrument and the CE mark as well.

3.1 Operating Elements



fig. 3.1

1	Platform	Sample measuring plate
2	Charge LED	Lights up while charging
3	Display	See Chapter 3.1.1
4	Off button	Switches the balance On
5	Mode button	Toggles between “g” and “g/m ² ”
6	Tare key	For determining the net weight with the packaging on
7	Base feet	4 adjustable feet at the bottom of the instrument
8	On/Zero key	For switching on and zero setting of the balance
9	Bubbel level	For horizontal alignment of the balance
10	Connector	For connecting the AC adapter

3.1.1 Display Details

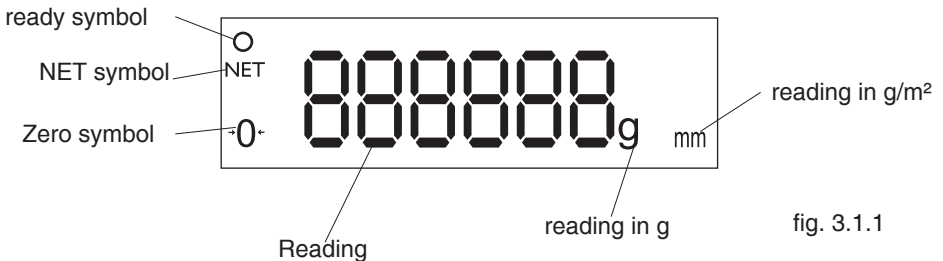
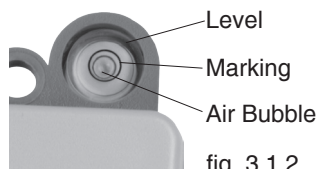

fig. 3.1.1

3.1.2 Aligning the Instrument

Before switching on the instrument, the balance must be set up in such a way that it is exactly horizontal. This means: The air bubble of the level must be precisely in the middle of the marking. The instrument is provided with four setscrews on the bottom for horizontal alignment.



3.2 Connecting the AC Adapter

The instrument features a rechargeable battery. Besides battery operation, it can also be run using the supplied AC adapter.

When the battery is low, the display indicates .



Before connecting the AC adapter, check the supply voltage.

Claims for warranty or liability will not be accepted for AC adapters from other manufacturers.

The built-in battery is also recharged when the instrument is on. An empty battery needs to be charged for at least 10 hours. If you have not used the instrument for a longer time, you will need to recharge the battery to make full use of the battery capacity.

In the case of continuous use with the AC adapter connected and a fully charged battery, you must disconnect the AC adapter after work to prevent overloading and thus damage to the battery.

To connect the AC adapter:

- Plug in the AC adapter cable at the power connector.

Polarity of the connector





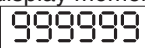

fig. 3.2

3.2.1 Switch-On

Requirements:

- AC adapter connected or battery charged.

- Press the  button.

The display momentarily shows  and then counts from  down to . The display then indicates the instrument model  followed by .

Once complete, the zero point is set automatically (auto zero) and the balance is ready to measure. Zero setting can also be carried out manually if you have enabled the corresponding function as described in Chapter 3.3.1.



After switching on the instrument, allow approx. 30 minutes for thermal stabilization

3.2.2 Switch-Off

Auto power off:

- The instrument switches off automatically after a certain time of non-use. The timeout can be set as described in Chapter 3.3.1. Three warning tones are issued before the unit powers off. The switch-off procedure cannot be canceled.

Manual switch-off:

- Press the  button.



When the battery is being charged, the charge LED will remain on until the battery has been fully charged.

3.3 Settings

3.3.1 Function Settings

General information:

The settings for:

- Zero setting (auto zero)
- Timeout
- Display backlight
- Calibration weight

of the balance can be changed in the following way.

Requirement:

Instrument switched off as described in Chapter 3.2.2.

Zero setting:

- Press and hold the  button and switch on the instrument with the  button.

The display shows .

- By pressing the  button, you can now choose between

Manual  zero setting

Automatic  zero setting

No function .

The default setting is  automatic zero setting.

- You can now either return to the measuring mode by pressing the  button five times

or

Press the  button once to set the

Timeout:

- By pressing the  button, you can now choose between

No power off 

Power off after 5 min. 

Power off after 10 min. 

Power off after 20 min. 

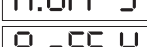
Power off after 30 min. 

of non-use.
The default setting is  power off after 20 min.

- You can now either return to the measuring mode by pressing the  button four times

or

Press the  button once to set the

3.3.1 Function Settings (Cont.)

Display Backlight:

- By pressing the  button, you can now choose between

No backlight 

Permanent backlight 

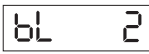
Backlight while weighing  .

The default setting is  backlight while weighing.

- You can now either return to the measuring mode by pressing the  button three times

or

Press the  button once to set the

Calibration Weight:

- By pressing the  button, you can now choose between

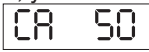
Calibration weight 50 g 

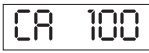
Calibration weight 100 g 

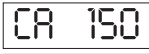
Calibration weight 150 g 

Calibration weight 200 g 

Calibration weight 300 g 

The default setting is  calibration weight 200 g

- Press the  button.

The display shows  .

- Press the  button.

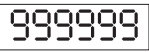
The display counts from  down to  .

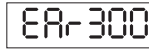
The display then indicates the instrument model 

followed by  .



The settings you last made remain stored in the EAR memory even after the instrument is switched off.

3.3.2 Measuring Mode Selection

You can change the measuring mode from grams per square meter (g/m^2) to grams (g).

Example:

- The instrument is set to g/m^2 .
The display shows g and mm.

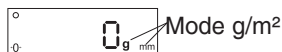

- Press the  button.
The instrument switches from g/m^2 to grams.

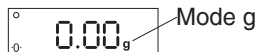



- Press the  button.
The instrument is reset to the zero point (auto zero).
The display shows the selected measuring mode.

3.3.3 Zero Setting (ZERO)

After selecting the measuring mode, you have to set the instrument to zero.

To carry out zero setting:

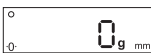
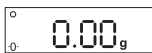
- Press the  button.

The display shows according to the mode  or ,
the  symbol appears left below in the display.

3.4 Measuring Procedure

3.4.1 Standard Measuring Procedure

Requirements:

- Instrument switched on as described in chapter 3.2.1.
Function settings selected as required, as described in chapters 3.3.1 and 3.3.2.
The ready symbol is displayed.
- Zero setting (auto zero) carried out as described in chapter 3.3.3.

Ready symbol



To measure the process material:

- Place the sample to be measured on the platform.



The READY symbol must be shown on the display to ensure that the display indicates correct readings.

- Before starting the next measurement, make sure that the ready symbol is displayed.

3.4.2 Measuring Procedure with Container (tare subtractive weighing)

The available measuring range of the instrument can be reduced by the tare weight.
For example:

Measuring range	300 g
Minus tare (container etc.)	50 g
Remaining measuring range	250 g

Requirements:



- Instrument switched on as described in chapter 3.2.1.
Function settings selected as required, as described in chapters 3.3.1 and 3.3.2.
The ready symbol is displayed.
- Zero setting (auto zero) carried out as described in chapter 3.3.3.

Ready symbol



To measure with the tare function:

- Place the container on the platform.

- Press the  button, the display shows .
NET appears under the ready symbol.
The tare has been subtracted from the measuring range.



The ready symbol must be shown on the display to ensure that the display indicates correct readings.

To leave the tare function:

- Remove the container from the platform and press the  button.

The display shows .

- Press the  button.

The instrument is reset to the zero point (auto zero).

3.4.3 Error Messages

Overload:

The display shows .

The weight on the platform exceeds the measuring range.

Underload:

The display shows .

The platform has not been placed on the instrument.

Remedy:

- Place the platform on the support plate.

Zero setting not possible:

The switch-on procedure of the instrument is interrupted.

The display shows .

The platform is not placed on the balance or a weight greater than 20 % of the measuring range has been placed on the platform.

3.5 Calibration of the Instrument

The balance is supplied with a 200 g calibration weight for recalibrating the instrument on site or checking the measurement accuracy.

Requirement:

Instrument switched off as described in chapter 3.2.2.

The calibration weight is adjusted according chapter 3.3.1

There is no sample or container on the platform.

To calibrate the instrument:

- Press the  button.

The display shows .

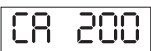
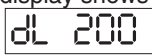

- Press the  button for 3 seconds

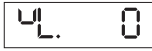

- The display shows momentarily the adjusted calibration weight  and than  is flashing.

- Place the calibration weight on the platform.

- Wait until the display has stabilized and shows .

- Remove the calibration weight from the platform.

After the calibration has occurred the display shows momentarily  and than .

If the calibration occurs not with the adjusted calibration weight, the display shows momentarily  and than .

3.5 Calibration of the Instrument (Cont.)

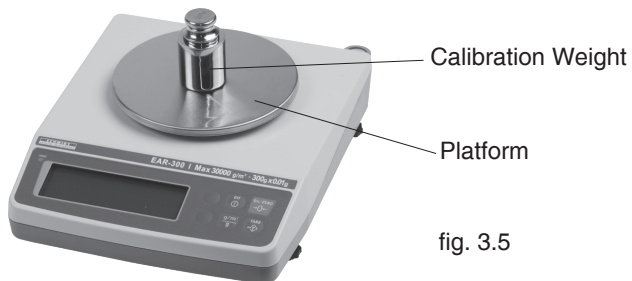

Do not subject the instrument to shock or vibration during calibration.

Press the keys gently and not too quickly in succession.

4 Service and Maintenance

The instrument is easy to maintain. Depending on operating time and load, the instrument should be checked according to the locally valid regulations and conditions (as described in Chapter 3.5). The use of other test methods than the procedure described in Chapter 3.5 may cause deviating measuring results.

5 Cleaning

For cleaning the unit, do not use any



AGGRESSIVE SOLVENTS

such as trichloroethylene or similar chemicals.



NO WARRANTY OR LIABILITY

shall be accepted for damage resulting from improper cleaning.

6 Correspondence

Should you have any questions regarding the instrument or Operating Instructions, or their use, please indicate above all the following details which are given on the ID plate:

- 1.) Model
- 2.) Serial number

7 Repairs

Shipping instructions:

We kindly ask for return free of charge for us, if possible by airmail parcel. All occurring charges, if any (such as freight, customs clearance, duty etc.), will be billed to customer. For return from foreign countries, we ask you to include a proforma invoice with a low value for customs clearance only, e.g. 50 Euro, each and to advise the shipment in advance by fax or eMail.



To avoid unnecessary follow-up questions, and the resulting loss of time or possible misunderstandings, please return the instrument with a detailed fault description to our service department.