

TENSION SENSORS

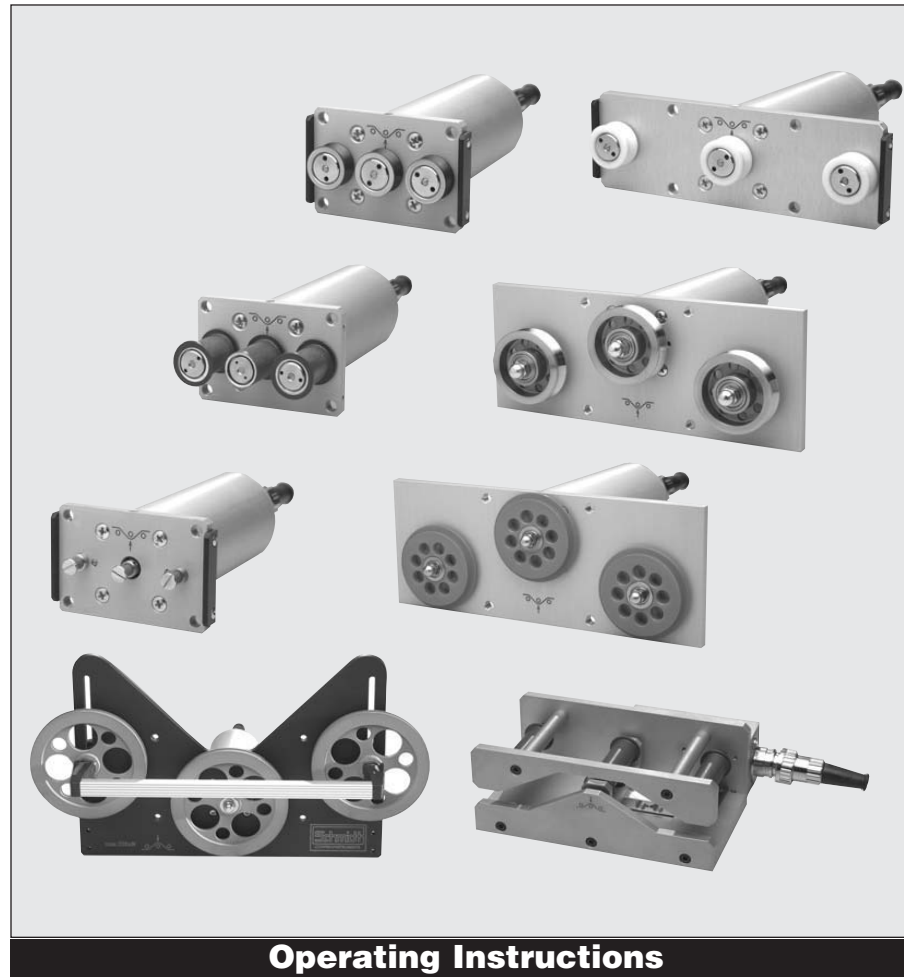

6.0 WARRANTY

ELECTROMATIC Equipment Co., Inc. (ELECTROMATIC) warrants to the original purchaser that this product is of merchantable quality and confirms in kind and quality with the descriptions and specifications thereof. Product failure or malfunction arising out of any defect in workmanship or material in the product existing at the time of delivery thereof which manifests itself within one year from the sale of such product, shall be remedied by repair or replacement of such product, at ELECTROMATIC's option, except where unauthorized repair, disassembly, tampering, abuse or misapplication has taken place, as determined by ELECTROMATIC. All returns for warranty or non-warranty repairs and/or replacement must be authorized by ELECTROMATIC, in advance, with all repacking and shipping expenses to the address below to be borne by the purchaser.

THE FOREGOING WARRANTY IS IN LIEU OF ALL OTHER WARRANTIES, EXPRESSED OR IMPLIED, INCLUDING BUT NOT LIMITED TO, THE WARRANTY OF MERCHANTABILITY AND FITNESS FOR ANY PARTICULAR PURPOSE OR APPLICATION. ELECTROMATIC SHALL NOT BE RESPONSIBLE NOR LIABLE FOR ANY CONSEQUENTIAL DAMAGE, OF ANY KIND OR NATURE, RESULTING FROM THE USE OF SUPPLIED EQUIPMENT, WHETHER SUCH DAMAGE OCCURS OR IS DISCOVERED BEFORE, UPON OR AFTER REPLACEMENT OR REPAIR, AND WHETHER OR NOT SUCH DAMAGE IS CAUSED BY MANUFACTURER'S OR SUPPLIER'S NEGLIGENCE WITHIN ONE YEAR FROM INVOICE DATE.

Some State jurisdictions or States do not allow the exclusion or limitation of incidental or consequential damages, so the above limitation may not apply to you. The duration of any implied warranty, including, without limitation, fitness for any particular purpose and merchantability with respect to this product, is limited to the duration of the foregoing warranty. Some states do not allow limitations on how long an implied warranty lasts but, notwithstanding, this warranty, in the absence of such limitations, shall extend for one year from the date of invoice.

ELECTROMATIC Equipment Co., Inc.
600 Oakland Ave. Cedarhurst, NY 11516—USA
Tel: 1-800-645-4330/ Tel: 516-295-4300/ Fax: 516-295-4399

TABLE OF CONTENTS

1.0	Introduction	2
1.1	Upacking	
1.2	Optional Accessories	
2.0	Operation	3
2.1	First Installation	
2.2	Internal Sensor Calibration	
2.3	ZERO Adjustment	
2.4	GAIN Adjustment	
2.5	Checking The Adjustment	
3.0	Specifications	7
4.0	Pin Assignments	7
5.0	Appendix: Available Models	8
5.1	TE Models	
5.2	TP Models	
5.3	TE-24 Models	
5.4	TE-22 Models	
5.5	TF Models	
5.6	TERX Models	
5.7	BTMS Models	
6.0	Warranty	12

Every precaution has been taken in the preparation of this manual. Electromatic Equipment Co., Inc., assumes no responsibility for errors or omissions. Neither is any liability assumed for damages resulting from the use of information contained herein. Any brand or product names mentioned herein are used for identification purposes only, and are trademarks or registered trademarks of their respective holders.

1.0 INTRODUCTION

These Operating Instructions refer to Model TE sensor; they are also applicable to the following models:

TP, TE-24, TE-22, TF, TERX, BTMS

1.1 Unpacking

When the sensor is delivered without a display and data analysis unit:

- 1 Diode connector, 8-pin
- 1 Operating Instructions

Unpack the instrument and inspect it for any shipping damage. Notices of defect must be filed immediately, at the latest within 10 days on receipt of the goods.

1.2 Optional Accessories

Option DC: Analog output 0 - 10 V DC

Option MA: Analog output 4 - 20 mA

5.6 TERX Models

Model	Tension Ranges cN	*Measuring Head Width mm	Roller Widths
TERX-100	0 - 100	60	7, 10, 15, 20
TERX-200	0 - 200	60	7, 10, 15, 20
TERX-500	0 - 500	60	7, 10, 15, 20
TERX-1000	0 - 1000	60	7, 10, 15, 20
TERX-2000	0 - 2000	120	7, 10, 15, 20



TERX guide rollers:

Guide Rollers	Line Speed m/min max.	Roller Material
Standard	1000	Hardcoated aluminium (Exception: 7 mm rollers are made of nickel-plated steel)

5.7 BTMS Models

Model	Tension Ranges cN	Roller Widths
BTMS-1000	0 - 1000	30, 36, 41, 50, 100
BTMS-2000	0 - 2000	30, 36, 41, 50, 100
BTMS-5000	0 - 5000	10, 15, 20, 30, 36, 41, 50, 100
BTMS-10K	0 - 10 daN	10, 15, 20, 30, 36, 41, 50, 100
BTMS-20K	0 - 20 daN	10, 15, 20, 30, 36, 41, 50, 100
BTMS-50K	0 - 50 daN	10, 15, 20, 30, 36, 41, 50, 100



BTMS guide rollers:

Guide Rollers	Line Speed m/min max.	Roller Material
Standard	1000	Hardcoated aluminium

5.4 TE-22 Models

Model	Tension Ranges cN	*Measuring Head Width mm	**FACTORY Calibration Material
TE-22-50	0 - 50	150	PA: 0.12 mm Ø
TE-22-100	0 - 120	150	PA: 0.12 mm Ø
TE-22-200	0 - 200	150	PA: 0.12 mm Ø
TE-22-500	0 - 400	150	PA: 0.20 mm Ø
TE-22-1000	0 - 1000	15	PA: 0.30 mm Ø



TSL guide rollers:

V-grooved	Line Speed m/min max.	Roller Material
Standard	4000	Hardcoated aluminium (Nr. R12021)
Option T	4000	Plastic (PVC reed) (Same dimension as standard roller)

5.5 TF Models

Model	Tension Ranges cN	*Measuring Head Width mm	**FACTORY Calibration Material
TF-100	0 - 120	270	PA: 0.12 mm Ø
TF-200	0 - 200	270	PA: 0.12 mm Ø
TF-500	0 - 400	270	PA: 0.20 mm Ø
TF-1000	0 - 100	270	PA: 0.30 mm Ø
TF-2000	0 - 200	270	PA: 0.50 mm Ø
TF-5000	0 - 500	270	PA: 0.80 mm Ø

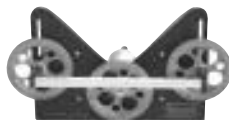

TSF guide rollers:

V-grooved	Line Speed m/min max.	Roller Material
Standard	5000	Hardcoated aluminium (Nr. R12045)

2.0 OPERATION



WARNING

The device must not be operated in explosion hazard areas and must not come into contact with aggressive substances.

To avoid damage, do not move the center roller by hand.

Tensions that exceed the tension range of the device by more than 100% may cause a permanent deformation of the measuring spring and must be avoided under any circumstances.

2.1 First Installation

1. Install the sensor at the desired measuring location.
2. Connect the sensor with the supplied or existing display unit. The pin assignment of the 8-pin connector located on the rear side of the sensor is described in section 4.0.
3. If the material path is other than vertical or if the process material deviates significantly from the factory calibration material, you have to carry out zero and gain adjustment, as described in [section 2.3](#) and [2.4](#), before first installation.
3. Wait approx. 10 minutes for the sensor to warm up.
4. Thread the process material through the measuring rollers, following the thread acquisition symbol on the front of the sensor.

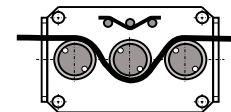

2.2 Internal Sensor Calibration

General Notes:

If the sensor was delivered together with a display unit, ZERO and GAIN adjustment should only be performed on the supplied display unit.

All tension meters are calibrated with standard materials—such as polyamide-monofilament (PA)—according to the factory procedure; the material path is vertical (Model BTMS horizontal).

Any difference in process material size and rigidity from the standard material may cause a deviation of the accuracy.

In 95% of all industrial applications the factory calibration has been proven to provide the best results and is used for comparative purposes.

If required, you can operate the sensors with a material path other than vertical.

If the process material differ significantly in size, rigidity and shape we recommend special calibration using customer material. In the case of a material path other than vertical or special calibration using customer material you have to carry out static zero and gain adjustment once again as described in [Chapters 3.2.1](#) and [3.2.2](#).

2.3 ZERO Adjustment

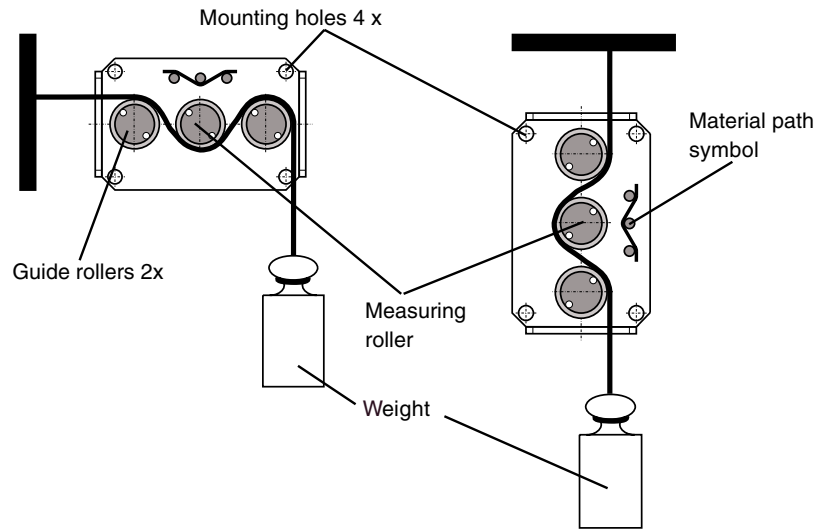

1. Install the sensor at the measuring locations in the desired measuring position, using the provided mounting holes.
2. Remove the countersunk head screws (M2.5) ZERO and GAIN on the rear side of the sensor.
3. Wait approx. 10 minutes for the measuring head to warm up.
4. Thread the process material through the measuring rollers, following the thread acquisition symbol on the front of the sensor.

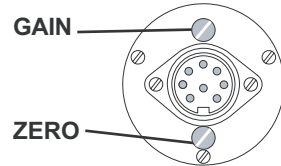

WARNING When threading the process material through the rollers, follow the material acquisition symbol on the front of the sensor. If force is applied to the middle sensing roller in the incorrect direction, damage could result.

- NOTE:** Since zero and gain adjustments are always performed statically the display values may differ under dynamic load.
5. Suspend a weight that corresponds to, for example, 10% of the tension range from the measured material (see diagram above).
 6. Connect a voltmeter to pins 1 and 7 of the connector provided on the rear side of the sensor. See section 4.0

5.2 TP Models

Model	Tension Ranges cN	*Measuring Head Width mm	**FACTORY Calibration Material
TP-50	0 - 50	64	PA: 0.12 mm Ø
TP-100	0 - 120	64	PA: 0.12 mm Ø
TP-200	0 - 200	64	PA: 0.12 mm Ø
TP-500	0 - 400	64	PA: 0.20 mm Ø



TP guide pins:

Guide Pins	Line Speed m/min max.	Pin Material
Standard	6000	Oxide ceramic 4 mm Ø (Nr. R12056)

5.3 TE-24 Models

Model	Tension Ranges cN	*Measuring Head Width mm	**FACTORY Calibration Material
TE-24-1000	0 - 1000	150	PA: 0.30 mm Ø
TE-24-2000	0 - 2000	150	PA: 0.50 mm Ø
TE-24-5000	0 - 5000	150	PA: 0.80 mm Ø
TE-24-10K	0 - 10 daN	200	PA: 1.00 mm Ø
TE-24-20K	0 - 20 daN	200	PA: 1.50 mm Ø
TE-24-50K	0 - 50 daN	200	Steelrope 1.50 mm Ø (7 x 7 x 0.20)



TE-24 guide rollers:

V-grooved	Line Speed max. m/min	Roller Material
Standard	4000	Hardened steel roller (Nr. R10006)
U-grooved Option R1	4000	Hardened steel roller (Radius R5)

5.0 APPENDIX: AVAILABLE MODELS

In addition to the standard specifications listed below, the following custom modifications are also available:

- Special tension ranges
- Customized roller dimensions
- Special calibration using customer supplied material

5.1 TE Models

Model	Tension Ranges cN	*Measuring Head Width mm	**FACTORY Calibration Material
TE-50	0 - 50	64	PA: 0.12 mm Ø
TE-100	0 - 100	64	PA: 0.12 mm Ø
TE-200	0 - 200	64	PA: 0.12 mm Ø
TE-500	0 - 500	64	PA: 0.20 mm Ø
TE-1000	0 - 1000	64	PA: 0.30 mm Ø
TE-2000	0 - 2000	124	PA: 0.50 mm Ø
TE-5000	0 - 5000	124	PA: 0.80 mm Ø
TE-10K	0 - 10 daN	124	PA: 1.00 mm Ø
TE-20K	0 - 20 daN	224	PA: 1.50 mm Ø
TE-50K	0 - 50 daN	224	Steel rope: 1.50 mm Ø (7 x 7 x 0.20)



TE Guide Rollers

V-grooved	Line Speed m/min max.	Roller Material
Standard	2000	Hardcoated aluminium (Nr. R10008)
Option K	3500	Hardcoated aluminium
Option H	5000	Plasma-coated aluminium (for Model TE-100 and higher ranges)
Option T	1000	Plastic (POM) black
Option W	1000	Nickel-plated steel
Option ST	1000	Hardened steel
Option B	1000	Steel tempred, especially for measuring Tyrecord
Option CE	1000	Ceramic
Asymmetrical groove ASY	1000	Hardcoated aluminium (for Model TE-100 and higher ranges)
U-grooved Option U	2000	Hardcoated aluminium

7. Insert a screw driver (with a point width of up to 1.9 mm) into the now accessible ZERO opening of the housing and adjust the potentiometer until the connected voltmeter shows a measured voltage of, for example:

Sensor Model TS -200:

Weight 20 cN = Display 0.100 V for the TS standard version

or

Weight 20 cN = Display 1.00 V for the TS version with 10 V output signal.



Do not tilt the screwdriver as this may damage the potentiometer.

WARNING

2.4 GAIN Adjustment

Requirement: ZERO adjustment (section 2.3) must be carried out first.

1. Thread the process material through the measuring rollers, following the thread acquisition symbol on the front of the sensor.
2. Suspend a weight that corresponds to, for example, 95% of the tension range from the measured material (see diagram on page 4).
3. Insert a screw driver (with a point width of up to 1,9 mm) into the now accessible GAIN opening of the housing (see diagram on page 4) and adjust the potentiometer until the connected voltmeter shows a measured voltage of, for example:

Sensor Model TS-200:

Weight 190 cN = Display .950 V for the TS standard version

or

Weight 190 cN = Display 9.50 V for the TS version with 10 V output signal.

4. Check the adjustment with a fresh portion of the process material and repeat the adjustments if required, following the direction in section 2.3 and 2.4.
5. Screw in the countersunk head screws ZERO and GAIN on the rear side of the sensor.

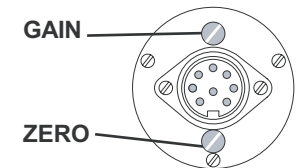

2.5 Checking the Adjustment

For general information, refer to section 2.2.

Requirements:

1. The sensors must be installed at the measuring location. Connect the sensor with the supplied or existing display unit.

NOTE: The pin assignment of the 8-pin connector located on the rear side of the sensor is described in section 4.0. Wait approx. 10 minutes for the sensor to warm up.

Checking procedure:

1. Thread the process material through the measuring rollers, following the red marking on the front of the sensor.

 **WARNING** When threading the process material through the rollers, follow the material acquisition symbol on the front of the sensor. If force is applied to the middle sensing roller in the incorrect direction, damage could result.

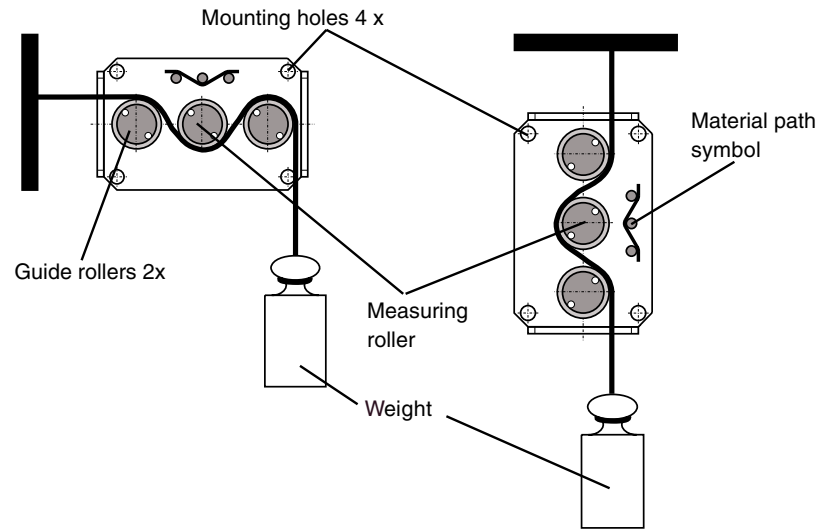

2. Suspend a weight that corresponds to the tension to be measured (pay attention to the correct unit of measure) from the measured material, vertically, as shown above. (Always use a fresh portion of the material to be measured.)
3. The tension value on the connected display unit should be equal to the value of the suspended weight. If this procedure shows a deviation beyond the allowable tolerance and a reliable operation is no longer allowed, the instrument has to be readjusted, following the directions in sections 2.3 and 2.4

3.0 SPECIFICATIONS

Calibration

According to factory procedure Suitable for 95% of applications. PA = Polyamide Monofilament. If the material to be measured differs significantly from the factory calibration material in diameter, rigidity, shape, etc., we recommend calibration using customer material. For this purpose, a material sample of at least 5 m should be supplied. International unit for tension force: 1 cN = 1.02 g = 0.01 N 1 daN = 1.02 kg = 10 N

Accuracy

Remainder of range and other calibration material

For 10% to 100% of range: $\pm 1\%$ full scale

$\pm 3\%$ full scale or better

Overload protection

100% of range

Measuring principle

Strain gauge bridge

Measuring roller deflection

0.5 mm, max.

Natural frequency of measuring spring

Approx. 500 Hz, depending on tension range

Signal processing

Analog

Temperature coefficient

Zero point: less than $\pm 0.05\%$ full scale / °C

Output signal

Option DC

Option MA

0 - 1 V DC Impedance: > 5 kOhm (standard) Option

0 - 10 V DC

4 - 20 mA

Damping (f g)

Standard: approx. 30 Hz (other values on request)

Temperature range

10 - 45 °C Air humidity: 85% RH, max.

Power supply

Standard: 12 to 18 V DC (21mA) (regulated)

Housing

Aluminium

4.0 PIN ASSIGNMENTS

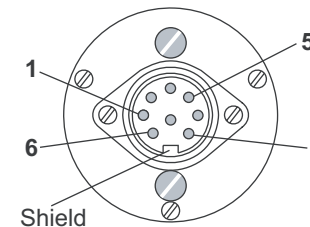

Pin No.	Signal	Description
1	GND	Ground - analog signal
2		Not assigned
3		Not assigned
4		Not assigned
5	+12 to 24 VDC regulated	Supply voltage
6	GND	Ground - analog signal
7	0-1 VDC	
8		Not assigned