

Selecting the nominal load

The maximum force applied to the sensor's bearing journal is the factor used to select the nominal measurement force capacities of the transducer. These maximum forces are the product of the maximum tensile force encountered, the reversing system geometry and the idler pulley's own weight.

The expressions used here are:

- F_{EM} = Effective measurement force applied to the transducer
- = Point marking the measurement axis of the sensor
- F_G = Weight of the idler pulley due to the force of gravity
- F_K = Components in the reversing pulley's weight
- F_N = Sensor's nominal measurement force
- F_R = Force resulting from tensile force load and angle of contact
- F_Z = Tensile force load
- α = Angle of contact at the reversing pulley
- β = Included angle between the sensor measurement axis and the force vector
- μ = Included angle between the sensor measurement axis and the vertical

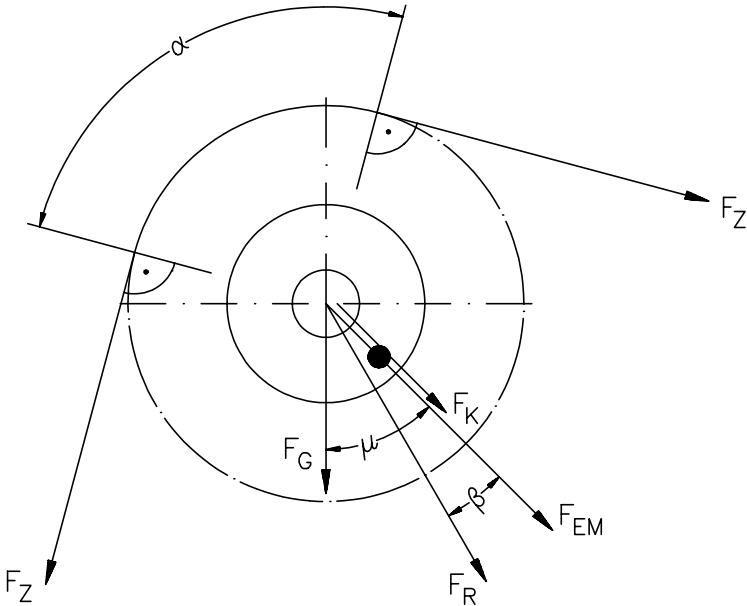

Fig. 1:
Forces acting on the sensor bearing journal

Calculating the nominal load

The resultant force F_R is calculated on the basis of the tensile force F_Z and the angle of contact α :

$$F_R = 2 \cdot F_Z \cdot \sin \alpha/2$$

An angle of contact of between 20 and 180° is recommended to achieve satisfactory measurement precision.

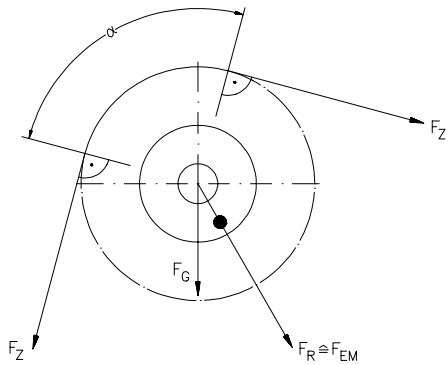

Fig. 2:
Measurement axis and force vector are congruent

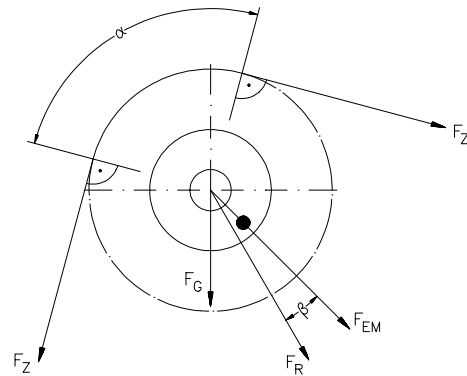

Fig. 3:
Measurement axis deviates from the force vector

The resultant force F_R is equivalent to the effective measurement load F_{EM} only when the measurement system axis of the sensor is exactly congruent to the force vector determined by the reversing system geometry (**Fig. 2**). This provision is satisfied in the normal installation situation.

If the sensor's measurement axis deviates from the force vector, then the effective measurement force F_{EM} is calculated on the basis of the resultant force F_R and the deviation angle β (**Fig. 3**).

$$F_{EM} = F_R \cdot \cos \beta$$

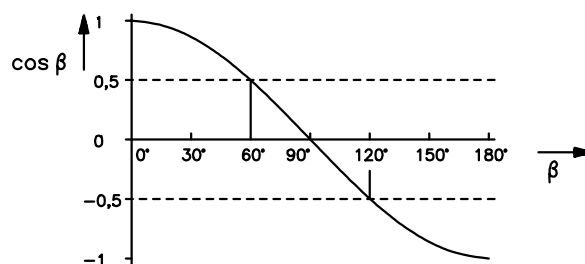

Fig. 4:
Curve for $\cos \beta$

As can be seen from the illustration (**Fig. 4**) the effective measurement load can be matched to the nominal measurement force in such a way that it is even possible to measure tensile forces for which the resultant F_R is greater than the sensor's nominal measurement force F_N .

When exploiting this phenomenon it is necessary to ensure that, if at all possible, the value does not fall below $\cos \beta = 0,5$ ($\Rightarrow \beta = 60^\circ$).

When selecting the nominal measurement force it is necessary to take into account the weight F_G of the idler pulley, particularly when working with small nominal forces (**Fig. 5**).

The F_K components which are effective along the sensor's measurement axis are added to the vertical weight forces F_G , taking the signs (i.e. the force directions) into account to determine the effective measurement load F_{EM} .

$$F_K = F_G \cdot \cos \mu$$

At a deviation angle of $\mu = 90^\circ$ the factor $\cos \mu$ goes towards zero and no component F_K appears in the sensor measurement axis (**Fig. 6**). It is possible to make good use of the phenomenon if, for instance, due to an unfavourable ratio between the effective measurement force F_{EM} and the pulley weight F_G the useful width of the output signal range and thus the resolution would be reduced.

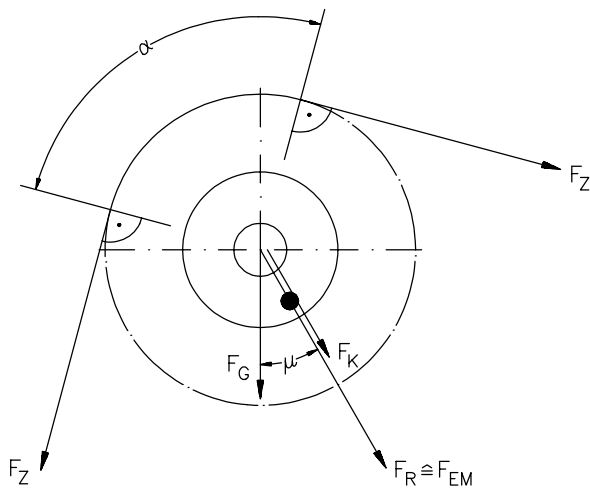

Fig. 5:
 F_{EM} and F_K are cumulative

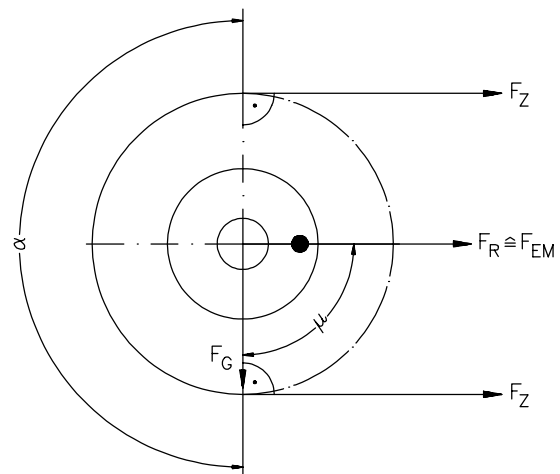

Fig. 6:
 $\cos \mu = 90^\circ \Rightarrow F_K = 0$

The sum of the effective measurement load F_{EM} and the F_K components may not exceed the sensor's nominal force.

$$F_{EM} + F_K < F_N$$

The sensor signal generated in response to the weight of the reversing pulley is neutralized electronically by the zero point balancing feature in the measurement amplifier, so that the signal for the effective measured force will always be available for use as the output magnitude or displayed value.