



Handheld Digital Tachometer Non-contact type  
with Dual Non-Contact, Contact Operation

# DT-2100

## Instruction Manual



Thank you for purchasing Nidec-Shimpo's Handheld High-Performance Digital Tachometer DT-2100. For instructions on how to use this product properly and optimally for a long period of time, please be sure to read this manual thoroughly before use.

- Enables measurement of a rotating body at a distance using integral laser beam
- Maximum of 1000 data point storage
- The organic light emitting display (OLED) allows enhanced viewing, even in dark locations
- Selectable meter or graphic display modes
- High accuracy measurement capability of +/-0.006%
- PC communication through USB with available software

Non-contact type digital tachometers are used to perform measurement by applying the supplied reflection tape to the rotating body of the object to be measured, and projecting the laser beam (red) to the tape. In addition, they can be used for contact type measurement by attaching the supplied contact adapter.

■ Inspection result certificate

We skip issuance of the inspection result certificate for this product. However, at the time of factory shipment total shipment inspection has been completed, and we have strictly confirmed that there is no error in measurement accuracy and operation. Your understanding is appreciated.

Before operation, maintenance and inspection, please carefully read this instruction manual and follow it for proper use.

After carefully reading this manual, be sure to store it in a safe and convenient place for easy reference.

## Safety Requirements

Be sure to observe

Before operation, maintenance and inspection, please carefully read this instruction manual and follow it for proper use. Start using only after you have read about the equipment's functions, safety information and precautions.

This instruction manual provides three grades of safety warnings: "Danger", "Warning" and "Caution". Each of them is an important description related to safety. Be sure to follow them.

- Danger** This indicates the possibility of fire, severe injury, and even death if a user disregards the instruction and operates the unit improperly.
- Warning** This indicates the possibility of severe injuries if a user operates the unit improperly.
- Caution** This indicates the possibility of minor injury or damage if a user operates the unit improperly.

● Limited Warranty

- We are not responsible for damages resulting from negligence through failure to follow the instructions set out in this manual.
- We are not responsible for damages resulting from earthquake and/or fire unrelated to us, actions by third parties, or any other accidents, intentional or through customer negligence, as well as from accidents caused by misuse or improper use under abnormal conditions.
- For information regarding assurance provisions, please read the attached warranty certificate.

**Warning**

- Do not look into the laser beam
- Do not point the laser beam at people
- Do not allow usage by children
- Do not contact the laser beam irradiation port with a rotating body  
If the unit comes into contact with a rotating body, damage may result to the laser.
- Do not measure using wet or oily hands, or with loosely fitted clothing.  
If hands slip during measurement, fingers or part of the hand may get caught in the rotating equipment.

**Caution**

- Be careful around installed reflective tape.**  
The reflection tape may come loose during high-speed rotation.

## INDEX

1. Part Names and Functions	2
2. Measurement Method	4
3. Measurement Display Description	6
4. Graph Display	8
5. Memory Function	9
5-1. Memory mode details	9
5-2. Memory registration in the memory group	10
6. Various Settings	11
6-1. Contents selection	11
6-2. Memory data display	11
6-3. User settings	15
6-4. System settings	22
7. Battery Replacement	34
8. Dimensional Drawing	34
9. Specifications	35

# 1. Part Names and Functions

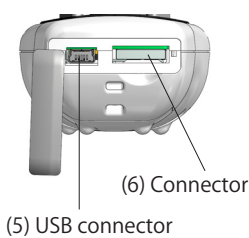
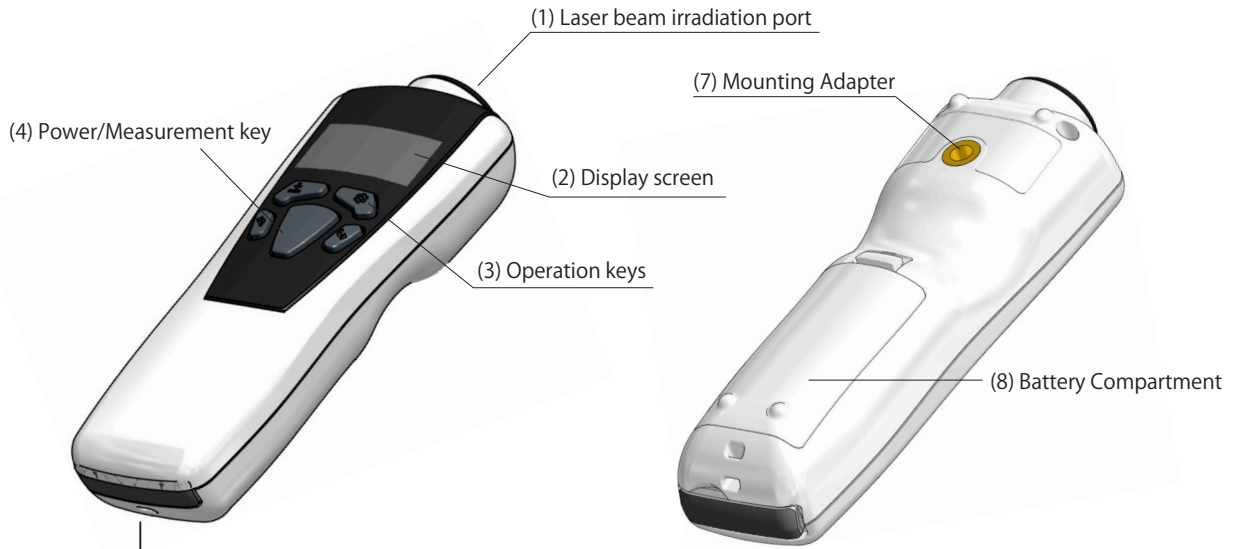

Parts name	Functions
(1) Laser beam irradiation port	Apply the reflection tape to the rotating body of the object to be measured. Project the laser beam (red) to the tape and measure the rotation speed.
(2) Display screen	Displays the measurement value.
(3) Operation keys 1 to 4	Used to change setting or store memory data.
(4) Power/Measurement key	Press this key to turn the power ON. The power will be turned OFF when no operation has been performed for a certain period of time. (Auto off function)
(5) USB connector	Power can be supplied through the USB connector. Also, connecting the unit to a PC enables communications using using the available software. (Sold separately)
(6) Connector	For internal production usage only
(7) Mounting Adapter	Allows unit to be mounted with its x/x ? threaded connection on tripod
(8) Battery Compartment	Uses two AA dry cell batteries

## ■ Operation keys and power/measurement key details

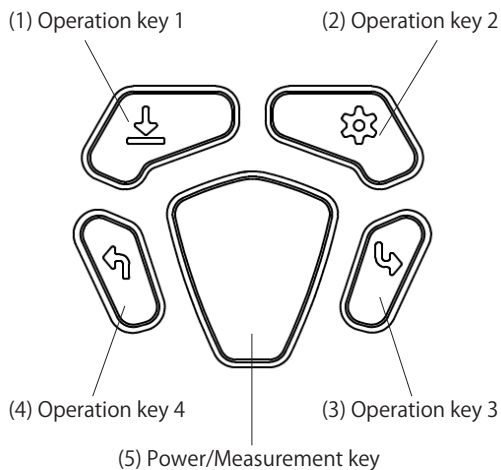

Parts name	Mode	Function
(1) Operation key 1	• Measurement mode (measurement standby, during measurement)	Used to store the memory data.
	• Set mode	Used to select the item.
	• Memory data display mode	Used to select the item.
(2) Operation key 2	• Measurement mode (measurement standby, during measurement)	Used to display memory data, and configure various settings.
	• Set mode	Used to select the item.
	• Memory data display mode	Used to select the item.
(3) Operation key 3	• Measurement mode (measurement standby, during measurement)	Used to switch the measurement display.
	• Set mode	Used as the enter key.
	• Memory data display mode	Used as the enter key.
(4) Operation key 4	• Measurement mode (measurement standby, during measurement)	Used to return the measurement display to the normal display.
	• Set mode	Used as the cancel key.
	• Memory data display mode	Used as the cancel key.
(5) Power/Measurement key	• When the power is OFF	Used to turn the power ON.
	• Measurement mode	Used to perform measurement.

## ■ Display screen details

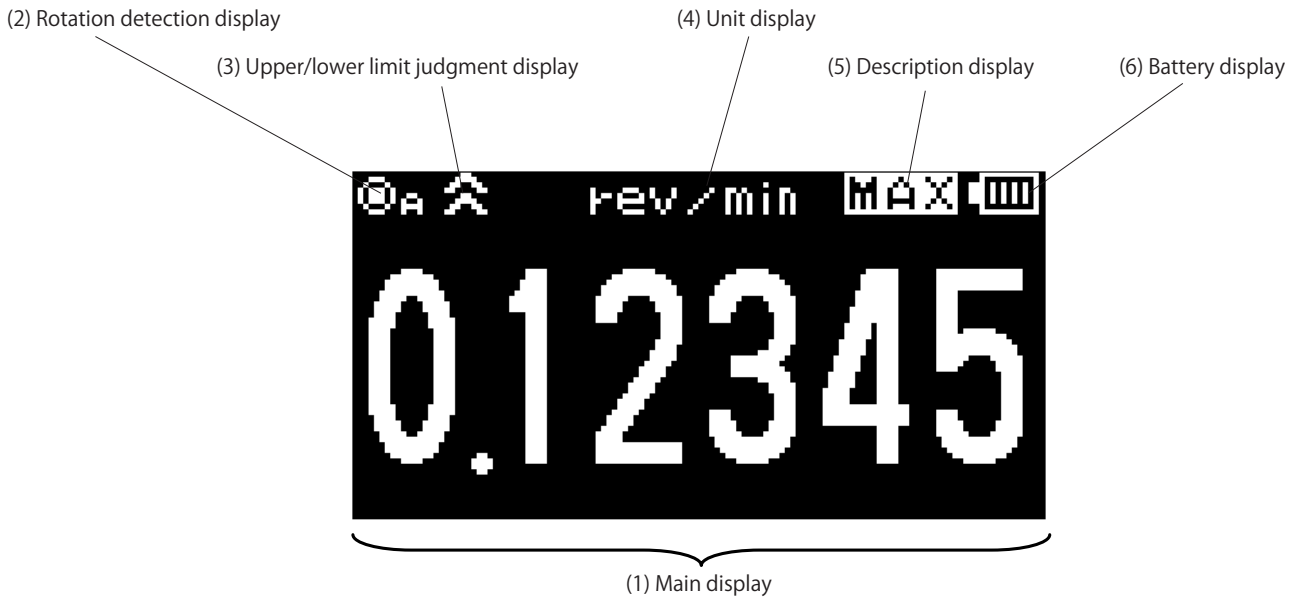

Key name	
(1) Main display	Displays the measurement value.
(2) Rotation detection display	Blinks during measurement. "A" is displayed when the contact adapter has been attached.
(3) Upper/lower limit judgment display	Displays judgment results of the display value according to the comparator setting.
(4) Unit display	Displays the current set unit.
(5) Description display	Displays description for the measurement value currently indicated.
(6) Battery display	Displays the remaining battery level. Blinks when the remaining battery level becomes close to 0. Also, the following mark is displayed when the power is supplied through the USB cable.

\*For screen protection, the display becomes dark when no operation has been performed for 10 seconds.  
Also, the display is turned OFF when no operation has been performed for 1 minute.

## ■ OVER display

When the measured value exceeds the display range, "- - - -" is displayed.  
Also, when it exceeds the measurement range, "OVER" is indicated in the unit display, and it blinks.

\*When "OVER" is indicated, the measurement accuracy is not guaranteed.

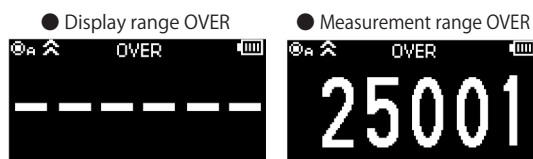

## 2. Measurement Method

### ■ Non-contact measurement

- 1 Apply the reflection tape to the object to be measured

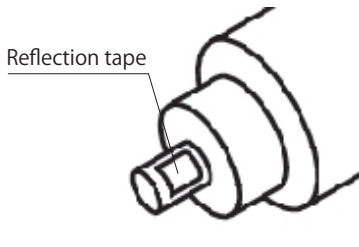

Apply the supplied reflection tape to the rotating body of the object to be measured.

- Do not apply to a rotating body smaller than the reflection tape.
- If the rotating body is glossy, apply black tape, or paint it black and apply the reflection tape.
- Before applying the reflection tape, wipe off water/oil on the attachment surface of the rotating body, and apply the tape without any irregularities.

- 2 Point the laser beam irradiation port to the object to be measured



Point the laser beam irradiation port to the reflection tape applied to the rotating body.

- Keep a distance of 50 to 4000 mm (2 in. to 13 ft.) between the reflection tape and irradiation port.

- 3 Press the power/measurement key to start measurement

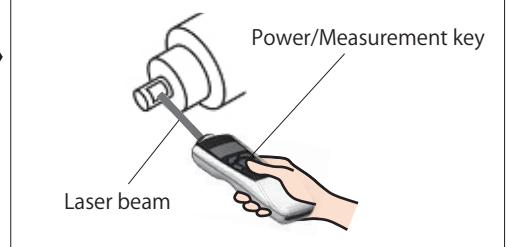

Press the power/measurement key, and start measurement.

- When the rotating body is static, the value "0" is displayed.
- When the rotating body rotates, the actual measurement data is displayed every display update cycle.

- 4 Power OFF when no operation has been performed for a certain period of time (Auto off function)

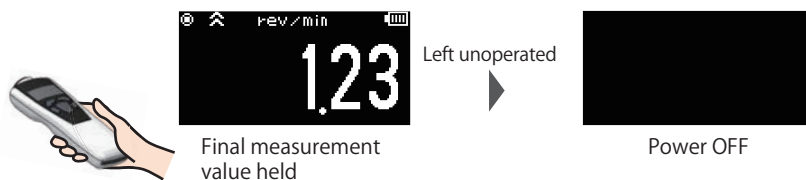

After measurement ends, the power is turned OFF when no operation has been performed for a certain period of time.

- The period of time until the power goes OFF can be set in "Auto off" in the system settings.
- When performing communication using the optional USB cable, the auto off function is disabled.

\*When the speed and distance units are selected in the unit setting, be sure to select "3. SET\_SYSTEM" in contents selection, and set the distance value per pulse in the "9. DIST/PULS" setting.

### ■ Precautions on measurement and handling

- ⊘ Never look into the laser beam. Failure to follow this could result in injury to the eyes.
- ⊘ Do not point the laser beam at people.
- ⊘ Do not allow usage by children.

## Contact measurement

Attaching the optional contact adapter enables measurement in the contact mode.

**1** Attach the contact adapter



**2** Select the appropriate contact fitting and attach.

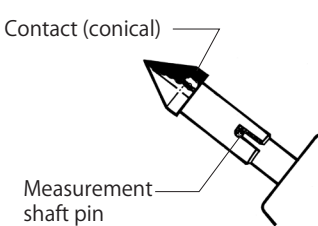

**3** In the "5. CONTACT" setting of "3. SET\_SYSTEM" in contents selection, change to "1. Contact" or "4. Contact (Low)".\*



For rotation speed measurement, attach the conical or funnel contact.

- When the object to be measured has a concave shaft, attach the conical contact.
- When the object to be measured has a conical shaft, attach the funnel contact.

\*When attaching the contact, securely fit the measurement shaft pin into the contact groove.

**4** Put the contact on the object to be measured

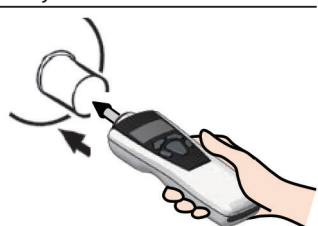

Carefully put the contact on the center of the rotating body of the object to be measured.

**5** Press the power/measurement key, and start measurement

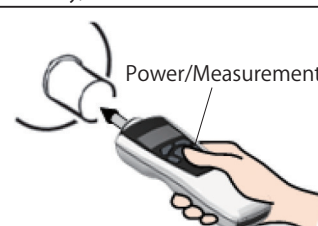

Press the power/measurement key, and start measurement.

\*Select "4. Contact (Low)" when using the optional contact adapter for low speed.

## When using the speed measurement wheel

**1** Attach the speed measurement wheel to the measurement shaft

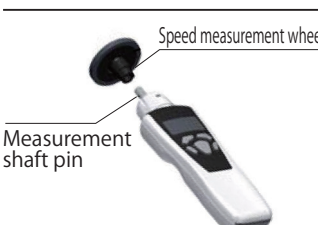

**2** Put the speed measurement wheel on the object to be measured

Carefully put the speed measurement wheel on the object to be measured (belt part, etc.).

**3** Press the power/measurement key, and start measurement



Refer to the above (rotation speed measurement)



Note) When attaching the wheel, securely fit the measurement shaft pin into the wheel groove.

\*The auto off function works similarly as in the case of non-contact measurement.

\*When performing the non-contact measurement again after contact measurement ends, be sure to select "3. SET\_SYSTEM" in contents selection, and set to "1. Contact" in the "5. CONTACT" setting.

\*When using the speed measurement wheel, in the "8. DIAMETER" setting of "3. SET\_SYSTEM" in contents selection, set the diameter value of the peripheral speed foil. When using the supplied speed measurement wheel (circumference of 6 inches), use it with the default value (diameter value of 48.5104 mm).

## Precautions on measurement and handling

-  Before measurement, securely fit the contact adapter to the contact. Also, during measurement, carefully put the contact on the rotating body of the object to be measured.
-  When attaching the speed measurement wheel for measurement, align it along the object to be measured, and do not push the wheel with excessive force. Also, for safety measurement, use with a speed of 300m/min (500cm/s, 18000m/h, ~ 18km/h, 197inch/s) or less.
-  When measuring a high-speed rotating body using the conical or funnel contact over a long period of time, note that the convex and concave portions of the contact may produce high heat.

### 3. Measurement Display Description

Press the operation key 3 in the measurement mode. The measurement value description to be displayed is switched. The types of the measurement value to be displayed are as follows:

Display	Description	
Normal	Description	Displays the measurement value corresponding to the selected unit.
	Display update	Updates every display update cycle.
Maximum value (Inactive during distance and manual measurement)	<b>MAX</b>	
	Description	Displays the maximum value from measurement start to end. This value is reset when the next measurement starts.
Minimum value (Inactive during distance and manual measurement)	<b>MIN</b>	
	Description	Displays the minimum value from measurement start to end. This value is reset when the next measurement starts, or the auto zero function is performed.
Average value (Inactive during distance and manual measurement)	<b>AVE</b>	
	Description	Displays the average value within the "GRAPH_TIME" specified in the system settings.
Acceleration rate (Inactive during distance and manual measurement)	<b>ACC</b>	
	Description	Displays the acceleration rate within the "GRAPH_TIME" specified in the system settings.
Prescale	<b>PRE</b>	
	Description	Displays the measurement value when "PRESCALE" is enabled. This feature is selected in the system settings. When "PRESCALE" is not specified, this is not displayed.
Prescale maximum value (Inactive during distance and manual measurement)	<b>RMAX</b>	
	Description	Displays the maximum value among the measurement values when "PRESCALE" is enabled. This value is reset when the next measurement starts.
Prescale minimum value (Inactive during distance and manual measurement)	<b>RMIN</b>	
	Description	Displays the minimum value among the measurement values when "PRESCALE" is enabled. This value is reset when the next measurement starts.
Prescale average value (Inactive during distance and manual measurement)	<b>RAVE</b>	
	Description	Displays the average value within the "GRAPH_TIME" specified in the system settings, among the measurement values when "PRESCALE" is enabled.
Prescale acceleration rate (Inactive during distance and manual measurement)	<b>RACC</b>	
	Description	Displays the acceleration rate within the "GRAPH_TIME" specified in the system settings, among the measurement values when "PRESCALE" is enabled.
	Description	Displays the measurement value when "PRESCALE" is enabled. This feature is selected in the system settings. When "PRESCALE" is not specified, this is not displayed.
	Display update	Updates every display update cycle.
Prescale maximum value (Inactive during distance and manual measurement)	<b>RMAX</b>	
	Description	Displays the maximum value among the measurement values when "PRESCALE" is enabled. This value is reset when the next measurement starts.
Prescale minimum value (Inactive during distance and manual measurement)	<b>RMIN</b>	
	Description	Displays the minimum value among the measurement values when "PRESCALE" is enabled. This value is reset when the next measurement starts.
Prescale average value (Inactive during distance and manual measurement)	<b>RAVE</b>	
	Description	Displays the average value within the "GRAPH_TIME" specified in the system settings, among the measurement values when "PRESCALE" is enabled.
Prescale acceleration rate (Inactive during distance and manual measurement)	<b>RACC</b>	
	Description	Displays the acceleration rate within the "GRAPH_TIME" specified in the system settings, among the measurement values when "PRESCALE" is enabled.
	Description	Displays the measurement value when "PRESCALE" is enabled. This feature is selected in the system settings. When "PRESCALE" is not specified, this is not displayed.
	Display update	Updates every "GRAPH_TIME".
Acceleration rate (Inactive during distance and manual measurement)	<b>ACC</b>	
	Description	Displays the acceleration rate within the "GRAPH_TIME" specified in the system settings.
Prescale	<b>PRE</b>	
	Description	Displays the measurement value when "PRESCALE" is enabled. This feature is selected in the system settings. When "PRESCALE" is not specified, this is not displayed.
Prescale maximum value (Inactive during distance and manual measurement)	<b>RMAX</b>	
	Description	Displays the maximum value among the measurement values when "PRESCALE" is enabled. This value is reset when the next measurement starts.
Prescale minimum value (Inactive during distance and manual measurement)	<b>RMIN</b>	
	Description	Displays the minimum value among the measurement values when "PRESCALE" is enabled. This value is reset when the next measurement starts.
Prescale average value (Inactive during distance and manual measurement)	<b>RAVE</b>	
	Description	Displays the average value within the "GRAPH_TIME" specified in the system settings, among the measurement values when "PRESCALE" is enabled.
Prescale acceleration rate (Inactive during distance and manual measurement)	<b>RACC</b>	
	Description	Displays the acceleration rate within the "GRAPH_TIME" specified in the system settings, among the measurement values when "PRESCALE" is enabled.
	Description	Displays the measurement value when "PRESCALE" is enabled. This feature is selected in the system settings. When "PRESCALE" is not specified, this is not displayed.
	Display update	Updates every "GRAPH_TIME".

#### ■ About calculation of the maximum value (MAX) and minimum value (MIN)

- As shown in the figure below, the instrument sets the measurement value when measurement starts with initial values of MAX<sub>0</sub> and MIN<sub>0</sub>. It then compares them to new measurement values every sampling cycle. New updated maximum and minimum values are created and displayed if they exceed (for MAX<sub>0</sub>) or are below (for MIN<sub>0</sub>). (Updates in the order of MAX<sub>0</sub> → MAX<sub>1</sub> → MAX<sub>2</sub>)
- The maximum and minimum values are reset when measurement starts.

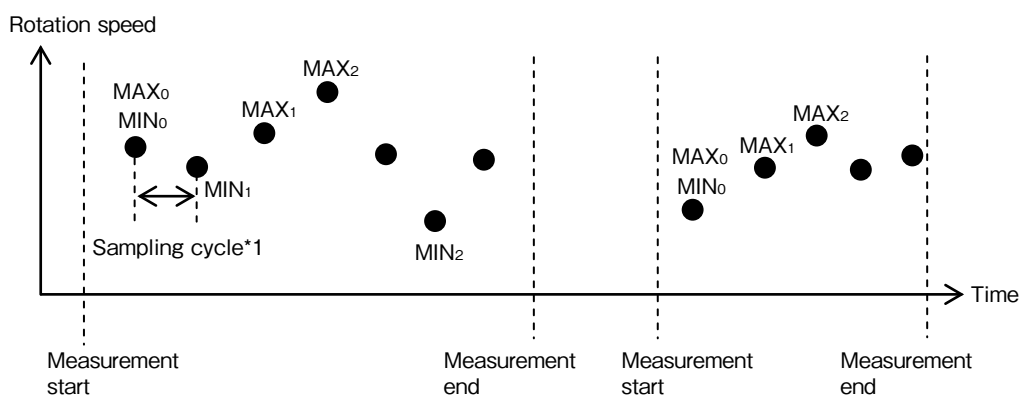

## ■ About calculation of the average value (AVE)

The average value is displayed by averaging the measurement values in the corresponding cycle every average value update cycle.

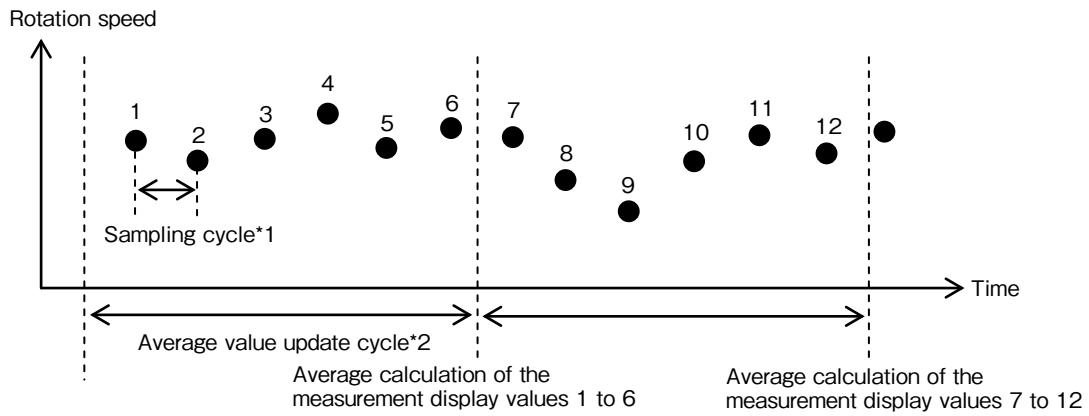

## ■ About calculation of the acceleration rate (ACC)

The acceleration rate is calculated based on  $v_0$  and  $v_1$  in the corresponding cycle every acceleration rate update cycle.

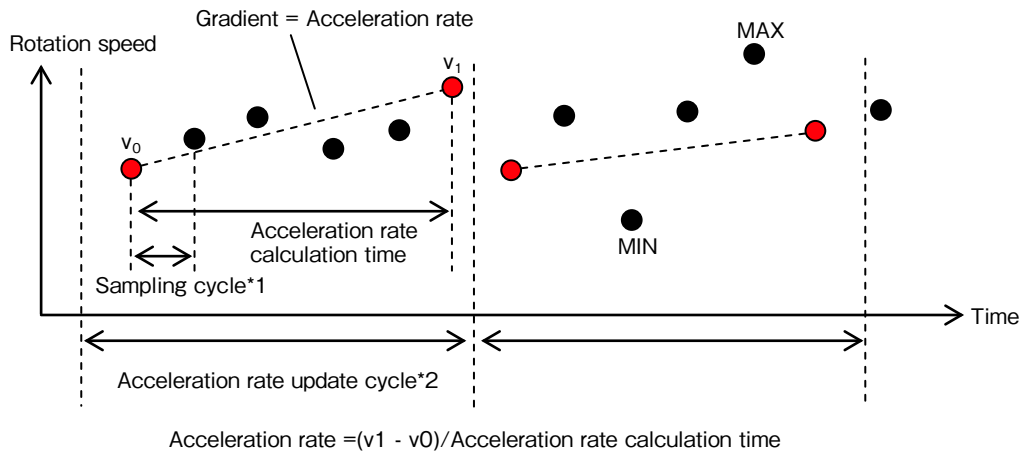

\*1 The sampling cycle is "DISP\_CYCLE" in the system settings.

\*2 The average value update cycle and acceleration rate update cycle are "3-2 Graph time" in the system settings.

\*The acceleration rate is displayed up to 5 digits, and when the speed is decreased, it is displayed as a negative value.

\*Minus value of the acceleration value cannot be displayed in the graph.



## 4. Graph Display

Using the "4. GRAPH\_DISP" setting of "2. SET\_USER" in contents selection enables the graph to be indicated on the display.

### (1) Graph\_1 (Line graph)

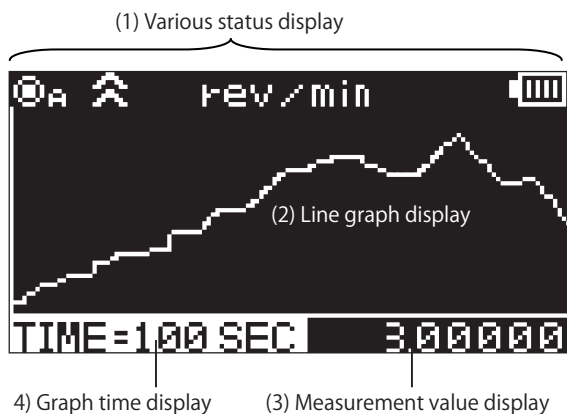

Parts name	Operation
(1) Various status display	Same as in the normal display
(2) Line graph display	Displays the line graph for the measurement value. Depending on selection one of the below will equal the graph values: Maximum value on the vertical axis: Graph maximum value setting Minimum value on the vertical axis: Graph minimum value setting Horizontal axis: Graph time setting value Graph flow: Graph flow setting value
(3) Measurement value display	Displays the current measurement value Can switch among MAX, MIN, AVE, and ACC
(4) Graph time display	Displays the graph time setting value

\*Update cycle: Every display update cycle

### (2) Graph\_2 (Gauge Mode)

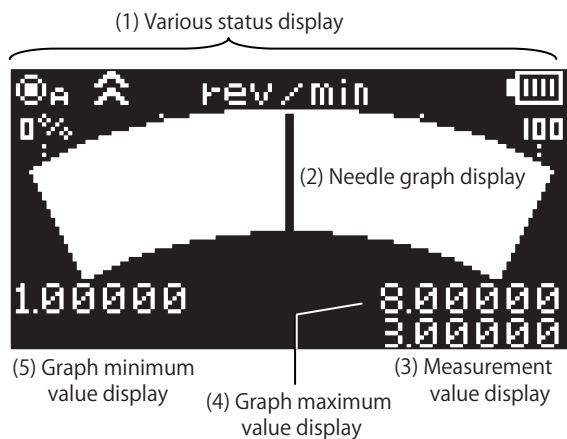

Parts name	Operation
(1) Various status display	Same as in the normal display
(2) Gauge Display	Displays the needle graph for the measurement value. Depending on selection one of the below will equal the gauge values: Graph maximum value: Graph maximum value setting Graph minimum value: Graph minimum value setting
(3) Measurement value display	Displays the current measurement value Can switch among MAX, MIN, AVE, and ACC
(4) Graph maximum value display	Displays the graph maximum value setting
(5) Graph minimum value display	Displays the graph minimum value setting

\*Update cycle: Every display update cycle

### (3) Graph\_3 (Bar graph)

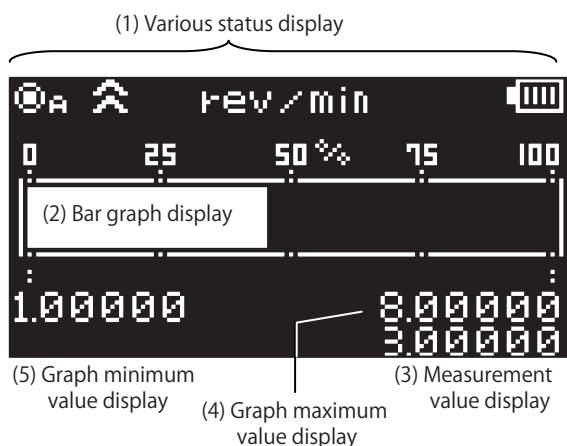

Parts name	Operation
(1) Various status display	Same as in the normal display
(2) Bar graph display	Displays the bar graph for the measurement value. Depending on selection one of the below will equal the gauge values: Graph maximum value: Graph maximum value setting Graph minimum value: Graph minimum value setting
(3) Measurement value display	Displays the current measurement value Can switch among MAX, MIN, AVE, and ACC
(4) Graph maximum value display	Displays the graph maximum value setting
(5) Graph minimum value display	Displays the graph minimum value setting

\*Update cycle: Every display update cycle

## 5. Memory Function

The measurement value can be registered and stored in the memory during measurement.

The stored data can be displayed in contents selection "1. DATA".

Registration contents and methods depend on the memory mode.

Set the memory mode in the "2. MEMORY\_MODE" of "2. SET\_USER" in contents selection.

### 5-1 Memory mode details

#### (1) Continuous memory mode

- In the continuous memory mode, the measurement value continues to be registered in the memory every display update cycle.
- The number of memory sets that can be registered in the continuous memory is up to 1000.
- For the continuous memory, the value description to be registered in the memory depends on the measurement display description.

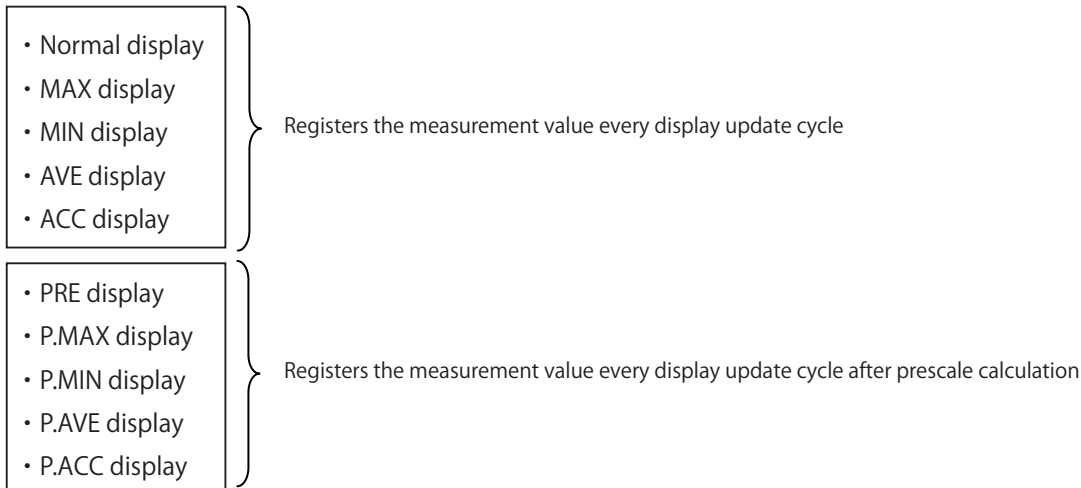

#### ● Memory registration operation

- Press the Operation key 1 once during measurement to start memory registration. Press it again to end memory registration.
- When turning measurement OFF, or switching to the contents selection mode during memory registration, memory registration ends at that moment.
- The unit and "Gr ○ \_ □□□□" are alternately displayed in the unit display part during memory registration.  
(○ shows the number of memory groups, and □ shows the number of memory points currently registered: 0001 to 1000)

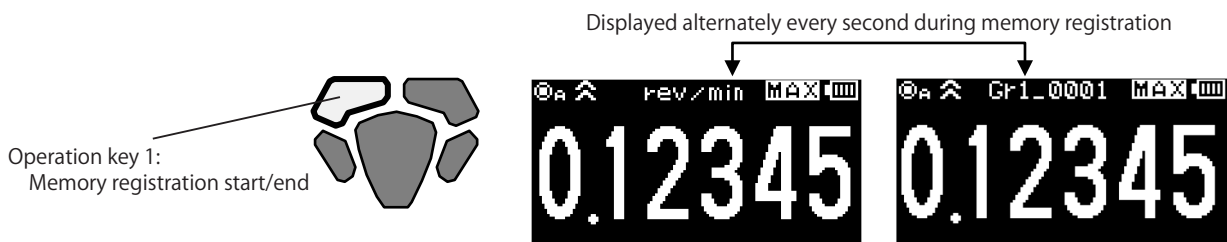

\*The continuous memory mode can be used only when one of the units from "rev/min" to "miles/h" is selected in the unit setting.

#### (2) Each memory mode

- In the each memory mode, only one set of the measurement value currently displayed is registered in the memory.
- The number of data points that can be registered in the each memory is up to 100.

#### ● Memory registration operation

- Press the operation key 1 once during measurement to register the display value at that moment in the memory.
- "Gr ○ \_ □□□□" is displayed for 1 second in the unit display part during memory registration.  
(○ shows the number of memory groups, and □ shows the number of memory sets currently registered: 001 to 100)



### (3) Statistics memory mode

- In the statistics memory mode, only the statistics data for the measurement value every display update cycle from memory registration start to end is registered in the memory.
- The number of data points that can be registered in the statistics memory is up to 100.

#### ● Memory registration operation

- Press the operation key 1 once during measurement to start memory registration, and press it again to end memory registration.
- When turning measurement OFF, or switching to the contents selection mode during memory registration, memory registration ends at that moment.
- The unit and "Gr ○ □□□□" are alternately displayed in the unit display part during memory registration.  
(○ shows the number of memory groups, and □ shows the number of memory sets currently registered: 001 to 100)

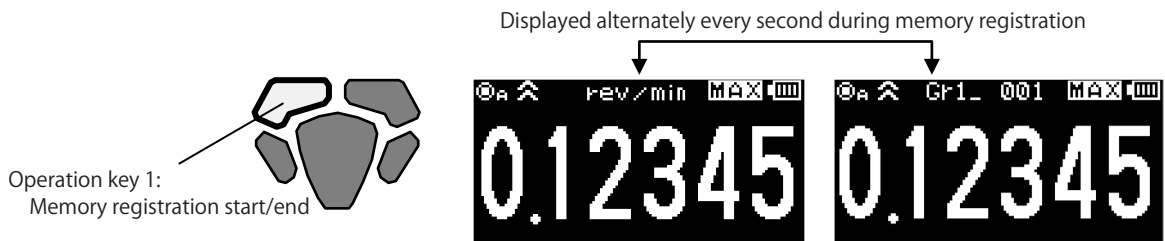

- \*In the statistics memory mode, the statistics data in a single registration is calculated from the measurement value for up to 100 times of display update. When the display update frequency exceeds 100 in a single registration, memory registration automatically ends.
- \*The statistics memory mode can be used only when one of the units from "rev/min" to "miles/h" is selected in the unit setting.

### 5-2. Memory registration in the memory group

- Start memory registration from the start memory group (that has been set in "3. START\_MEM" of "2. SET\_USER" in contents selection).
- When the number of memory groups reaches the number of memory sets in each group (that has been set in "4. MEM\_GROUP" of "3. SET\_SYSTEM" in contents selection), the memory group switches to the next one.
- When the number of memory sets exceeds the total number of memory sets for all memory groups, "FULL" is displayed in the unit display part. In this case, additional memory cannot be registered.

Example: When the start memory group is set to memory group 2

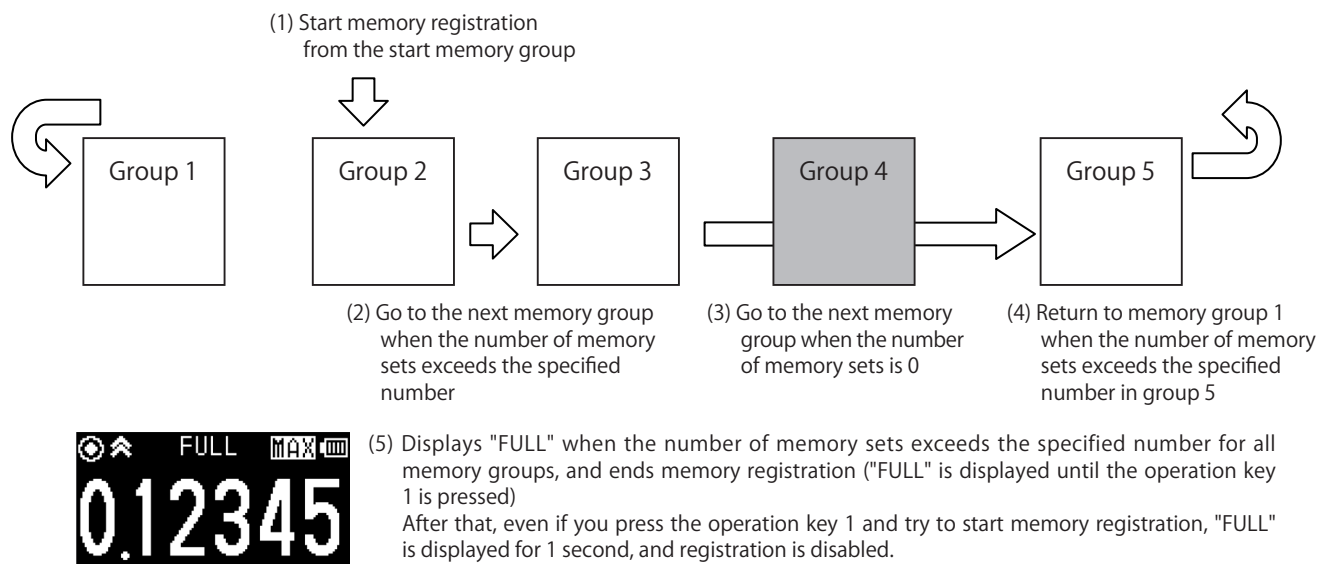

## 6. Various Settings

### 6-1. Contents selection

Press the operation key 2 in the measurement mode to switch the display to the contents selection mode.

English

[SET_CONTENTS]	
1. DATA	
2. SET_USER	
3. SET_SYSTEM	

Japanese

[選択してください]	
1. メモリ表示	
2. ユーザー設定	
3. システム設定	

Operation key	Operation
Operation key 1	Select the upper item Press and hold for 1 second to move continuously
Operation key 2	Select the lower item Press and hold for 1 second to move continuously
Operation key 3	Go to the selected item
Operation key 4	Return to the measurement mode

Item		Description
English	Japanese	
1	DATA	Go to the memory display
2	SET_USER	Go to the user settings
3	SET_SYSTEM	Go to the system settings

### 6-2. Memory data display

The memory data registered for each group can be checked in contents selection "1. DATA".

#### (1) Operation flow

Display the memory data according to the following operation.

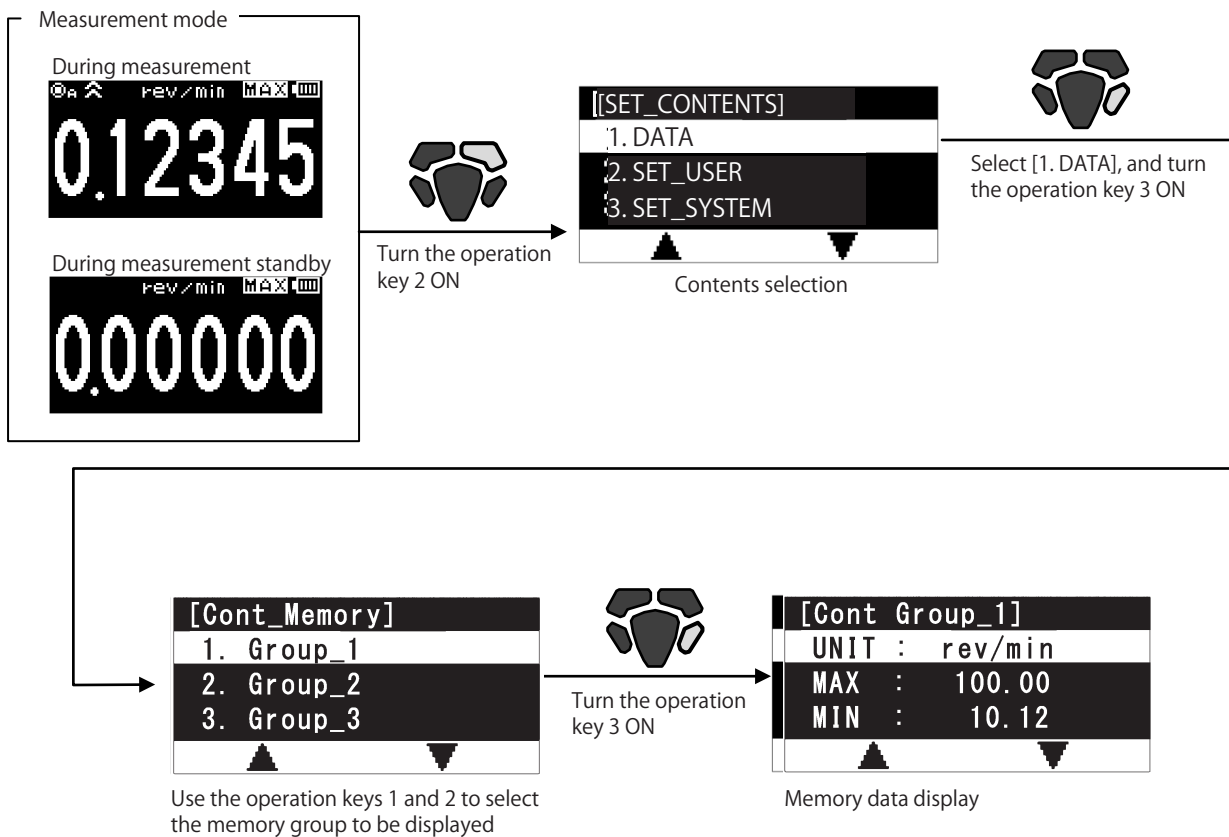

## (2) Memory data display/details

### ● Continuous memory display

Select "1. DATA" in contents selection to display the memory group selection screen.

#### (1) Memory group selection

Select the memory group you want to display.

English

[Cont_Memory]
1. Group_1
2. Group_2
3. Group_3
▲ ▼

Japanese

[連続メモリ]
1. グループ_1
2. グループ_2
3. グループ_3
▲ ▼

Operation key	Operation
Operation key 1	Select the upper item Press and hold for 1 second to move continuously
Operation key 2	Select the lower item Press and hold for 1 second to move continuously
Operation key 3	Go to memory description display
Operation key 4	Return to contents selection

Item		Description
English	Japanese	
1. Group_1	グループ_1	Displays memory group 1
2. Group_2	グループ_2	Displays memory group 2
3. Group_3	グループ_3	Displays memory group 3
4. Group_4	グループ_4	Displays memory group 4
5. Group_5	グループ_5	Displays memory group 5



#### (2) Memory data display

Select the memory group in (1), and press the operation key 3 to display the memory data for the selected memory group.

Use the operation keys 1 and 2 to change the display line.

English

[Cont_Group_1]
UNIT : rev/min
MAX : 100.0
MIN : 10.12
▲ ▼

Japanese

[連続メモリ グループ 1]
UNIT : rev/min
MAX : 100.0
MIN : 10.12
▲ ▼

Operation key	Operation
Operation key 1	Select the upper item Press and hold for 1 second to move continuously
Operation key 2	Select the lower item Press and hold for 1 second to move continuously
Operation key 3	Enabled when CLEAR is selected Go to memory clear
Operation key 4	Return to memory group selection

Display item	Description
UNIT :	Unit
MAX :	Maximum value
MIN :	Minimum value
AVE :	Average
SD :	Standard deviation
1 blank line	
1: ~	Displays the memory registration value
1000 :	for 1 to 1000 sets (max.)
CLEAR	Go to memory clear

#### (3) Memory clear

While the memory data is displayed, the "CLEAR" column is displayed in the last line of the data.

Select the "CLEAR" column, and press the operation key 3 to display the memory clear screen below.

Registration description in the memory group currently displayed can be cleared as necessary.

English

Data Clear?
1. No
2. Yes
▲ ▼

Japanese

消去しますか?
1. いいえ
2. はい
▲ ▼

Operation key	Operation
Operation key 1	Select the upper item Press and hold for 1 second to move continuously
Operation key 2	Select the lower item Press and hold for 1 second to move continuously
Operation key 3	Execute clear/Return to the continuous memory display without executing clear
Operation key 4	Return to the continuous memory display

Item		Description
English	Japanese	
1	No	Does not clear, and returns to the continuous memory display
2	Yes	Clears the continuous memory description

## ● Each memory display

Select "1. DATA" in contents selection to display the memory group selection screen.

### (1) Memory group selection

Select the memory group you want to display.

[Each_Memory]	
1. Group_1	
2. Group_2	
3. Group_3	

[単独メモリ]	
1. グループ_1	
2. グループ_2	
3. グループ_3	

Operation key	Operation
Operation key 1	Select the upper item Press and hold for 1 second to move continuously
Operation key 2	Select the lower item Press and hold for 1 second to move continuously
Operation key 3	Go to the memory data display
Operation key 4	Return to contents selection

Item			Description
	English	Japanese	
1	Group_1	グループ_1	Displays memory group 1
2	Group_2	グループ_2	Displays memory group 2
3	Group_3	グループ_3	Displays memory group 3
4	Group_4	グループ_4	Displays memory group 4
5	Group_5	グループ_5	Displays memory group 5



### (2) Memory data display

Select the memory group in (1), and press the operation key 3 to display the memory data for the selected memory group.

Use the operation keys 1 and 2 to change the display line.

English

[Each_Group_1]	
UNIT :	rev/min
MAX :	100.00
MIN :	10.12

Japanese

[単独メモリ グループ 1]	
UNIT :	rev/min
MAX :	100.0
MIN :	10.12

Operation key	Operation
Operation key 1	Select the upper item Press and hold for 1 second to move continuously
Operation key 2	Select the lower item Press and hold for 1 second to move continuously
Operation key 3	Enabled when CLEAR is selected Go to memory clear
Operation key 4	Return to memory group selection

Display item	Description
UNIT :	Unit
MAX :	Maximum value of the registration data
MIN :	Minimum value of the registration data
AVE :	Average of the registration data
SD :	Standard deviation of the registration data
1 blank line	
1: ~	Displays the memory registration value for 1 to
100 :	100 sets (max.)
CLEAR	Go to memory clear

While the memory data is displayed, the "CLEAR" column is displayed in the last line of the data.

Select the "CLEAR" column, and press the operation key 3 to display the memory clear screen below.

Registration description in the memory group currently displayed can be cleared as necessary.

English

Data Clear?	
1. No	
2. Yes	

Japanese

消去しますか?	
1. いいえ	
2. はい	

Operation key	Operation
Operation key 1	Select the upper item Press and hold for 1 second to move continuously
Operation key 2	Select the lower item Press and hold for 1 second to move continuously
Operation key 3	Execute clear/Return to the each memory display without executing clear
Operation key 4	Return to the each memory display

Item			Description
	English	Japanese	
1.	No	いいえ	Does not clear, and returns to the each memory display
2.	Yes	はい	Clears the each memory description

## ● Statistics memory display

Select "1. DATA" in contents selection to display the memory group selection screen.

### (1) Memory group selection

Select the memory group you want to display.

English	Japanese
<b>[Stats Memory]</b>	<b>[統計メモリ]</b>
1. Group_1	1. グループ_1
2. Group_2	2. グループ_2
3. Group_3	3. グループ_3

	Item		Description
	English	Japanese	
1	Group_1	グループ_1	Displays memory group 1
2	Group_2	グループ_2	Displays memory group 2
3	Group_3	グループ_3	Displays memory group 3
4	Group_4	グループ_4	Displays memory group 4
5	Group_5	グループ_5	Displays memory group 5



### (2) Memory data display

Select the memory group in (1), and press the operation key 3 to display the memory data for the selected memory group.

Use the operation key 1 to change the display line.

Use the operation key 2 to display the description of the next registration memory.

English	Japanese
<b>[Stats Group_1]</b>	<b>[統計メモリ グループ 1]</b>
No : 1	1. グループ_1
UNIT : rev/min	2. グループ_2
MAX : 10.12	3. グループ_3

Display item	Description
No:	1 - 100
UNIT:	Unit
MAX :	Maximum value
MIN :	Minimum value
AVE :	Average
SD :	Standard deviation

Operation key	Operation
Operation key 1	Select the upper item Press and hold for 1 second to move continuously
Operation key 2	Select the lower item Press and hold for 1 second to move continuously
Operation key 3	Go to memory description display
Operation key 4	Return to contents selection

Operation key	Operation
Operation key 1	Select the upper item Press and hold for 1 second to move continuously
Operation key 2	Select the lower item Press and hold for 1 second to move continuously
Operation key 3	Enabled when CLEAR is selected Go to memory clear
Operation key 4	Return to memory group selection

### (3) Memory clear

English	Japanese
<b>[Stats Group_1]</b>	<b>[統計メモリ グループ 1]</b>
CLEAR	CLEAR

Select CLEAR in the following item of the last No.

English	Japanese
<b>Data Clear?</b>	<b>消しますか?</b>
1. No	1. いいえ
2. Yes	2. はい

	Item		Description
	English	Japanese	
1	No	いいえ	Does not clear, and returns to the each memory display
2	Yes	はい	Clears the statistics memory description

Operation key	Operation
Operation key 1	Disabled
Operation key 2	Return to No. 1
Operation key 3	Go to memory clear
Operation key 4	Return to contents selection

Operation key	Operation
Operation key 1	Select the upper item Press and hold for 1 second to move continuously
Operation key 2	Select the lower item Press and hold for 1 second to move continuously
Operation key 3	Execute clear/Return to the statistics memory display without executing clear
Operation key 4	Return to the statistics memory display

## 6-3. User settings

### (1) Operation flow

Go to the user setting mode in the following operation.

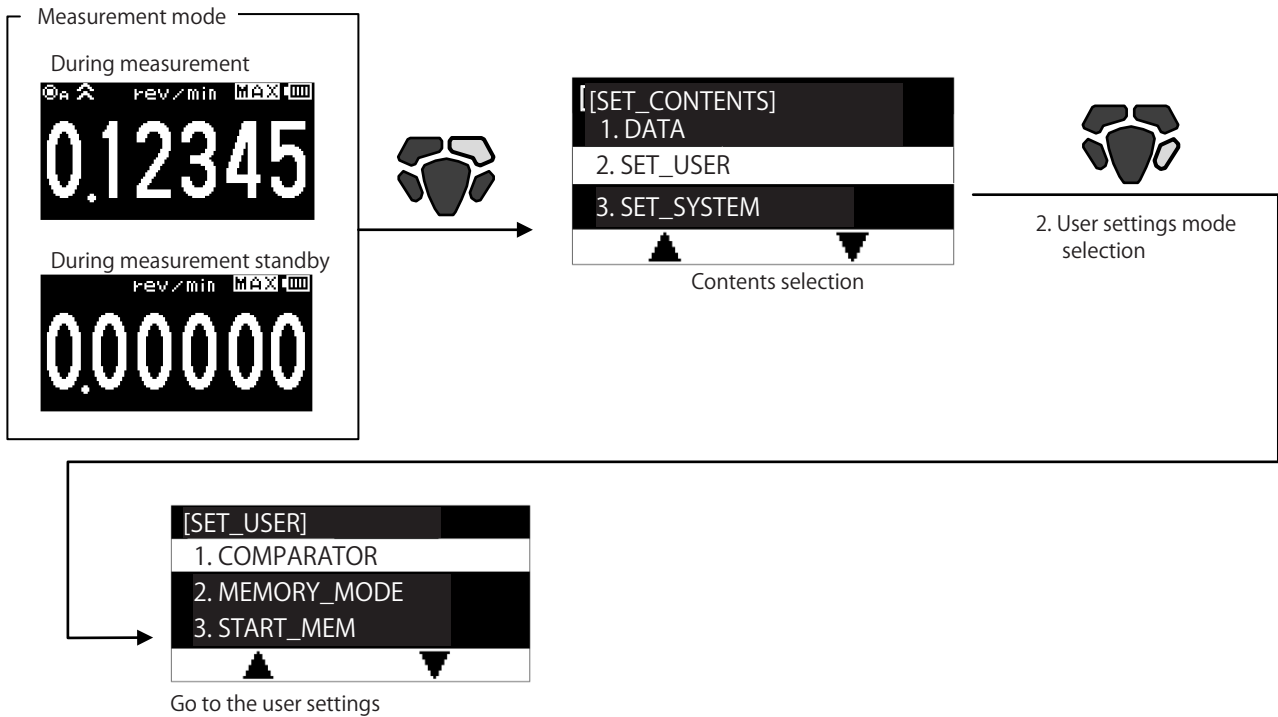

### (2) User settings - Setting item selection

Select the item to set in the following item selection screen, and perform detailed settings.

English

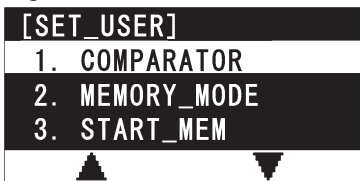

Japanese



Operation key	Operation
Operation key 1	Select the upper item Press and hold for 1 second to move continuously
Operation key 2	Select the lower item Press and hold for 1 second to move continuously
Operation key 3	Go to the detail settings of the selected item
Operation key 4	Return to the Contents selection



● List of the user settings

Item type	Item number	Main item title		Item number	Sub item title		Setting description		Default value	Remark
		English	Japanese		English	Japanese	English	Japanese		
User settings	1	COMPARATOR	コンパレータ	1-1	UPPER_LIMIT	上限値	0.00000 ~ 999999		0.00000	6-digit numerical value setting with decimal point
				1-2	LOWER_LIMIT	下限値	0.00000 ~ 999999		0.00000	
	2	MEMORY_MODE	メモリモード	—			Cont	連続	Cont	—
							Each	単独		
							Stats	統計		
	3	START_MEM	開始メモリ	—			Group_1	グループ_1	Group_1	—
							Group_2	グループ_2		
							Group_3	グループ_3		
							Group_4	グループ_4		
							Group_5	グループ_5		
	4	GRAPH_DISP	グラフ表示	—			Normal	通常表示	Normal	—
							Graph_1	グラフ 1		
							Graph_2	グラフ 2		
							Graph_3	グラフ 3		
	5	SAVE	設定保存	5-1	SEL_USER	設定グループ	User <input type="checkbox"/> Set_1	設定_1	—	—
							User <input type="checkbox"/> Set_2	設定_2		
				5-2	R/W	読出 / 保存	Used	読出	—	—
							Over <input type="checkbox"/> Write	保存		
	6	UNIT	単位	—			rev/min		rev/min	—
							m/min			
cm/min										
inch/min										
feet/min										
yards/min										
rev/sec										
m/sec										
cm/sec										
inch/sec										
km/h										
cm										
m										
km										
inch										
feet										
yards										
STP										

### (3) Detail settings for each item

#### (3-1) Comparator setting

In the "COMPARATOR" setting, set the UPPER\_LIMIT and LOWER\_LIMIT.

Compare UPPER\_LIMIT and LOWER\_LIMIT with the measurement display value, and display the judgment result in the screen.

- UPPER\_LIMIT  $\geq$  Measurement display value  $\geq$  LOWER\_LIMIT : OK judgment
- UPPER\_LIMIT < Measurement display value : NG judgment
- LOWER\_LIMIT > Measurement display value : NG judgment

#### (1) Upper limit value

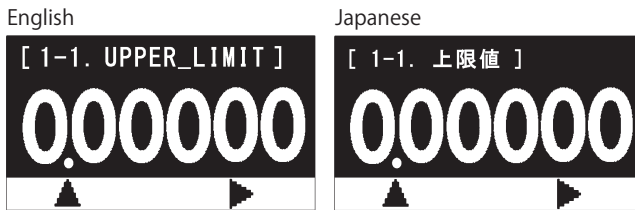

Operation key	Operation	
	When setting the numerical value	When setting the decimal point
Operation key 1	Increases the numerical value in the selected digit Press and hold for 1 second to increase continuously	Return to the numerical value setting
Operation key 2	Moves the digit Press and hold for 1 second to move continuously	Moves the decimal point Press and hold for 1 second to move continuously
Operation key 3	Go to 1-2	
Operation key 4	Return to the user setting	

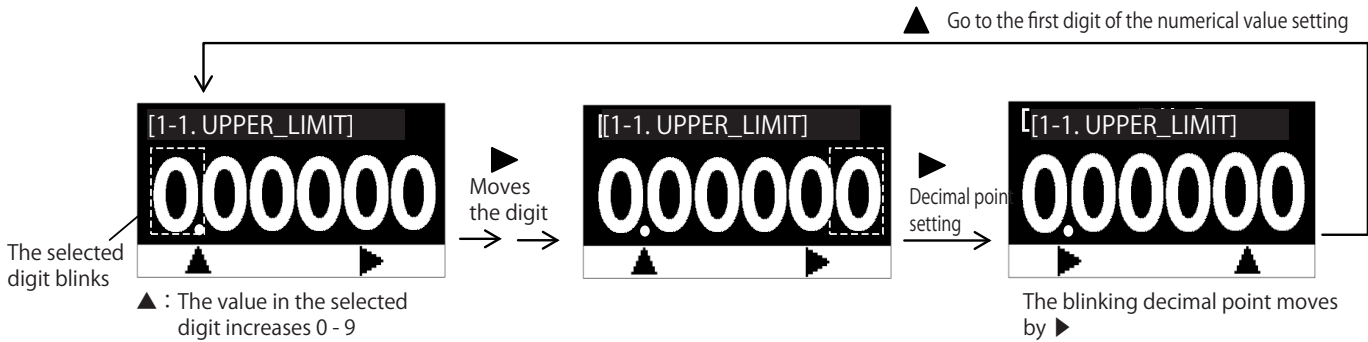

#### (2) Lower limit value

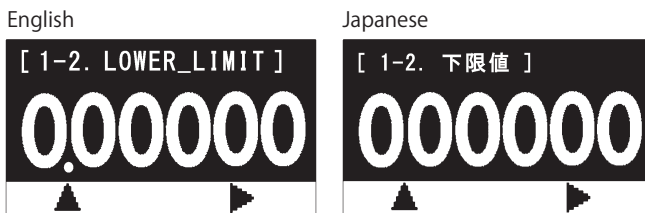

Operation key	Operation	
	When setting the numerical value	When setting the decimal point
Operation key 1	Increases the numerical value in the selected digit Press and hold for 1 second to increase continuously	Return to the numerical value setting
Operation key 2	Moves the digit Press and hold for 1 second to move continuously	Moves the decimal point Press and hold for 1 second to move continuously
Operation key 3	Enables the setting, and returns to the user settings.	
Operation key 4	Return to 1-1	

The continuous memory mode can be used only when one of "rev/min" to "km/h" is selected in the unit setting.

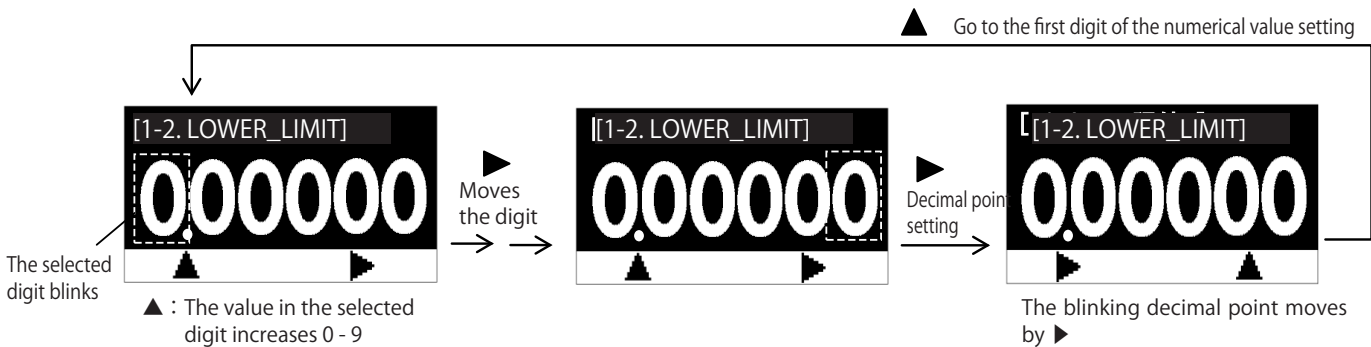

\*When both "UPPER\_LIMIT" and "LOWER\_LIMIT" are 0, judgment will be disabled, and the upper and lower limit judgment is not performed.

\*The display value is judged.

\*Values that represent UPPER\_LIMIT < LOWER\_LIMIT cannot be set.

### (3-2) Memory mode

Set the memory mode.

English

[ 2. MEMORY_MODE ]	
1. Cont	
2. Each	
3. Stats	
▲	▼

Japanese

[ 2. メモリモード ]	
1. 連続メモリ	
2. 単独メモリ	
3. 統計メモリ	
▲	▼

Operation key	Operation
Operation key 1	Select the upper item Press and hold for 1 second to move continuously
Operation key 2	Select the lower item Press and hold for 1 second to move continuously
Operation key 3	Go to memory clear
Operation key 4	Return to the user setting

	Item		Description
	English	Japanese	
1	Cont	連続メモリ	Continuous memory mode
2	Each	単独メモリ	Each memory mode
3	Stats	統計メモリ	Statistics memory mode

### Memory clear confirmation

When changing the memory mode, the memory data currently registered will be cleared.

When selecting "2. Yes" in the confirmation screen below, the memory data will be cleared.

When selecting "1. No", the change will not be reflected, and the display will return to the previous screen.

English

Data Clear?	
1. No	
2. Yes	
▲	▼

Japanese

メモリデータを消去しますか?	
1. いいえ	
2. はい	
▲	▼

	Item		Description
	English	Japanese	
1	No	いいえ	Memory data all clear not permitted
2	Yes	はい	Memory data all clear permitted

Operation key	Operation
Operation key 1	Select the upper item Press and hold for 1 second to move continuously
Operation key 2	Select the lower item Press and hold for 1 second to move continuously
Operation key 3	Execute clear/Return to the memory mode setting without executing clear
Operation key 4	Return to the memory mode setting

\*When changing the memory mode, the setting value of the number of registered memory sets for each memory group ("4. MEM\_GROUP" of "3. SET\_SYSTEM" in contents selection) is initialized to the value that corresponds to the memory mode.

### (3-3) Start memory group setting

Select the memory group to start memory registration.

English

[ 3. START_MEM ]	
1. Group_1	
2. Group_2	
3. Group_3	
▲ ▼	

Japanese

[ 3. 開始メモリ ]	
1. グループ 1	
2. グループ 2	
3. グループ 3	
▲ ▼	

Item			Description
	English	Japanese	
1	Group_1	グループ 1	Specifies the memory group to start memory registration as group 1
2	Group_2	グループ 2	Specifies the memory group to start memory registration as group 2
3	Group_3	グループ 3	Specifies the memory group to start memory registration as group 3
4	Group_4	グループ 4	Specifies the memory group to start memory registration as group 4
5	Group_5	グループ 5	Specifies the memory group to start memory registration as group 5

Operation key	Operation
Operation key 1	Select the upper item Press and hold for 1 second to move continuously
Operation key 2	Select the lower item Press and hold for 1 second to move continuously
Operation key 3	Enable the selected item, and return to the user settings.
Operation key 4	Return to the user setting

### (3-4) Graph display

The display can be switched to the graph display.

English

[ 4. GRAPH_DISP ]	
1. Normal	
2. Graph_1	
3. Graph_2	
▲ ▼	

Japanese

[ 4. グラフ表示 ]	
1. 通常表示	
2. グラフ 1	
3. グラフ 2	
▲ ▼	

Item			Description
	English	Japanese	
1	Normal	通常表示	Display change: Normal display
2	Graph_1	グラフ_1	Display change: Graph 1 (Line graph)
3	Graph_2	グラフ_2	Display change: Graph 2 (Needle graph)
4	Graph_3	グラフ_3	Display change: Graph 3 (Bar graph)

Operation key	Operation
Operation key 1	Select the upper item Press and hold for 1 second to move continuously
Operation key 2	Select the lower item Press and hold for 1 second to move continuously
Operation key 3	Enable the selected item, and return to the user settings.
Operation key 4	Return to the user setting

### (3-5) Setting save

#### (1) Setting group

The setting description can be saved in three patterns.  
The saved setting description can be read by selecting "Used".

English

[ 5-1. SEL_USER ]	
1.	User_Set_1
2.	User_Set_2
3.	User_Set_3
▲ ▼	

Japanese

[ 5-1. 保存グループ ]	
1.	設定 1
2.	設定 2
3.	設定 3
▲ ▼	

Item			Description
	English	Japanese	
1	User_Set_1	設定 1	Go to READ/WRITE in the saved group 1
2	User_Set_2	設定 2	Go to READ/WRITE in the saved group 2
3	User_Set_3	設定 3	Go to READ/WRITE in the saved group 3

Operation key	Operation
Operation key 1	Select the upper item Press and hold for 1 second to move continuously
Operation key 2	Select the lower item Press and hold for 1 second to move continuously
Operation key 3	Go to 5-2
Operation key 4	Return to the user setting

#### (2) Read/Write

English

[ 5-2. READ/WRITE ]	
1.	Used
2.	Over Write
▲ ▼	

Japanese

[ 5-2. 読出/保存 ]	
1.	読出
2.	保存
▲ ▼	

Item			Description
	English	Japanese	
1.	Used	読出	Reads the setting description from the settings 1 to 3 selected in (1)
2.	Over Write	保存	Writes the setting description to the settings 1 to 3 selected in (1)

Operation key	Operation
Operation key 1	Select the upper item Press and hold for 1 second to move continuously
Operation key 2	Select the lower item Press and hold for 1 second to move continuously
Operation key 3	Perform read/write, and return to the user settings
Operation key 4	Return to 5-1

\*The setting description to be saved includes the contents in "3. SET\_SYSTEM" in contents selection.

### (3-6) Unit

The display unit of the measurement value can be selected.

English



Japanese



Operation key	Operation
Operation key 1	Select the upper item Press and hold for 1 second to move continuously
Operation key 2	Select the lower item Press and hold for 1 second to move continuously
Operation key 3	Enable the selected item, and return to the user settings.
Operation key 4	Return to the user settings

Item (common to Japanese and English)			
1	rev/min	11	km/h
2	m/min	12	miles/h
3	cm/min	13	cm
4	inch/min	14	m
5	feet/min	15	km
6	yards/min	16	inch
7	rev/sec	17	feet
8	m/sec	18	yards
9	cm/sec	19	STP
10	inch/sec		

#### ● Unit type

- The units of items 1 to 12 are for speed measurement. They are used to measure the rotation speed and distance speed.
- The units of items 13 to 18 are for distance measurement. They are used to measure the distance value.
- The unit of item 19 STP is for manual measurement. It can be used to manually measure time required for one rotation, like using the stopwatch, and display the converted value in the rev/min unit.

#### ● About operation using the STP unit (manual measurement)

- When measuring in the STP unit, the measurement display is as follows. The display can be switched using the operation key 3.

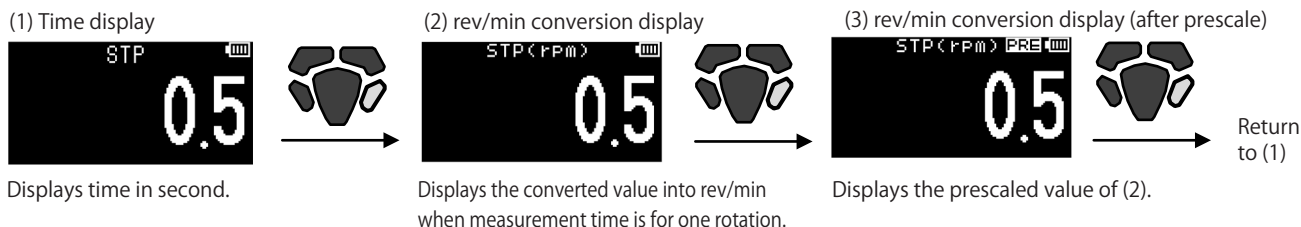

#### ● Limitations for each function due to unit selection

When selecting units other than the speed measurement units, there are differences in operation as follows.

	Cases when the display can be switched	Graph display	Memory registration			Auto zero
			Continuous memory	Statistics memory	Each memory	
Speed measurement	Normal display	○	Stores the normal display value in the memory	Calculates statistics from the normal display value	Registers the current display value	Enabled
	Maximum value display					
	Minimum value display					
	Average value display					
	Acceleration rate display					
	Prescale display					
	Prescale maximum value display					
	Prescale minimum value display					
	Prescale average value display					
Prescale acceleration rate display						
Distance measurement	Normal display	×	×	×	Registers the current display value	Disabled
	Prescale display					
Manual measurement	Normal display (time)	×	×	×	Registers the current display value	Disabled
	rev/min conversion display					
	rev/min conversion display (after prescale)					

\*For distance measurement and manual measurement, the graph display, continuous memory mode, and statistics memory mode cannot be used. Also, the auto zero function is enabled only when the speed measurement unit is used.

## 6-4. System setting mode

### (1) Operation flow

Go to the system setting mode in the following operation.

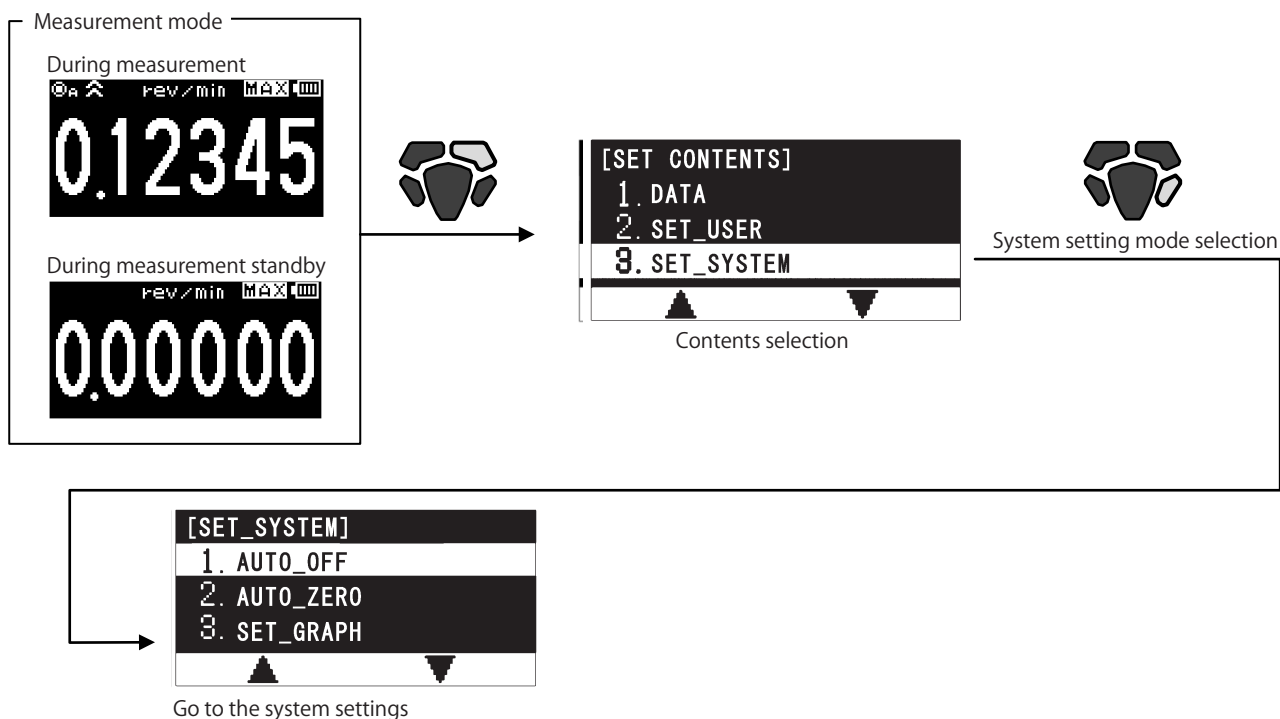

### (2) System settings - Setting item selection

Select the item to set in the following item selection screen, and perform detailed settings.

English

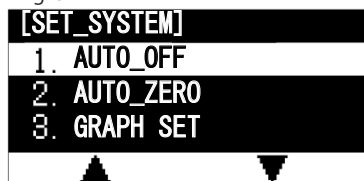

Japanese



Operation key	Operation
Operation key 1	Select the upper item Press and hold for 1 second to move continuously
Operation key 2	Select the lower item Press and hold for 1 second to move continuously
Operation key 3	Go to the detail settings of the selected item
Operation key 4	Return to the measurement mode

● List of the system settings

Item type	Item number	Main item title		Item number	Sub item title		Setting description		Default value	Remark				
		English	Japanese		English	Japanese	English	Japanese						
System settings	1	AUTO_OFF	オートオフ	—	—	—	1 min	1分	1 min	—				
							10 min	10分						
							30 min	30分						
	2	AUTO_ZERO	オートゼロ	—	—	—	1 sec	1秒	None	—				
							10 sec	10秒						
							30 sec	30秒						
							60 sec	60秒						
	3	SET_GRAPH	グラフ	—	3-1	GRAPH_FLOW	グラフ方向	Right	右方向	Right	—			
								Left	左方向					
					3-2	GRAPH_TIME	グラフ時間	—	—	—		1 sec	1秒	1 sec
												10 sec	10秒	
												50 sec	50秒	
	3-3	GRAPH_MAX	グラフ MAX 値	0.00001 ~ 999999	000100.	6-digit numerical value setting with decimal point								
	3-4	GRAPH_MIN	グラフ MIN 値	0.00001 ~ 999999	0.00000									
	4	MEM_GROUP	メモリグループ	—	4-1	MEM_GROUP	メモリグループ	Group_1	グループ_1	—	Select the memorygroup to be set in 4-2			
								Group_2	グループ_2					
								Group_3	グループ_3					
								Group_4	グループ_4					
								Group_5	グループ_5					
	4-2	Group_□	グループ_□	—	—	—	0 ~ 1000	0	when setting group other than group 1 in the cont memory mode					
0 ~ 100							0	when setting group other than group 1 in the cont memory mode						
0 ~ 100							0	when setting group other than group 1 in the cont memory mode						
5	CONTACT	接触 / 非接触	—	—	—	Contact	接触	Non Contact	—					
						Non Contact	非接触							
						Auto	自動検出							
						Contact (Low)	接触 (低速)							
6	DISP_CYCLE	表示更新周期	—	—	—	100 msec	1sec	—						
						500 msec								
						1 sec								
						5 sec								
7	PRESCALE	プリスケール	—	—	—	0.00001 ~ 999999.	000001.	6-digit numerical value setting with decimal point						
8	DIAMETER	直径	—	8-1	DIA_UNIT	直径単位	mm	mm	—					
							cm							
							m							
							inch							
							feet							
							yards							
8-2	DIAMETER	直径値	0.00001 ~ 999999.	48.5104	6-digit numerical value setting with decimal point									
9	DIST/PULSE	距離 / パルス	—	9-1	DIST_UNIT	距離単位	mm	mm	—					
							cm							
							m							
							inch							
							feet							
							yards							
9-2	DIST/PULSE	距離 / パルス	0.00001 ~ 999999.	000001.	6-digit numerical value setting with decimal point									
10	BRIGHTNESS	画面明るさ	—	—	—	—	20%	60%	—					
							40%							
							60%							
							80%							
							100%							
11	REVERSE_LCD	逆転表示	—	—	—	—	OFF	OFF	—					
							ON							
12	LANGUAGE	言語	—	—	—	—	日本語	English	—					
							English							
13	MEAS_OPR	計測スイッチ	—	—	—	—	Momentary	Momentary	—					
							Continuous			オルタネイト				
14	FACTY_DEFAULT	初期化	—	—	—	—	Yes	—	—					
							No			はい / いいえ				



### (3) Detail settings for each item

#### (3-1) Auto OFF

Set a period of time until the power is automatically turned OFF.

The power is turned OFF when the unoperated status continues for the specified auto off time.

English

[ 1. AUTO_OFF ]
1. 1 min
2. 10 min
3. 30 min
▲ ▼

Japanese

[ 1. オートオフ ]
1. 1 分
2. 10 分
3. 30 分
▲ ▼

Item			Description
	English	Japanese	
1.	1 min	1 分	Power OFF when the unoperated status continues for 1 minute
2.	10 min	10 分	Power OFF when the unoperated status continues for 10 minutes
3.	30 min	30 分	Power OFF when the unoperated status continues for 30 minutes

Operation key	Operation
Operation key 1	Select the upper item Press and hold for 1 second to move continuously
Operation key 2	Select the lower item Press and hold for 1 second to move continuously
Operation key 3	Enable the selected item, and return to the system settings
Operation key 4	Return to the system settings

- When performing communication using the optional USB cable, the auto off function is disabled.

#### (3-2) Auto zero

Set a period of time until the display is turned to 0 during measurement.

During measurement, when the rotation undetected status continues longer than the specified auto zero time, the measurement value display is reset to "0".

English

[ 2. AUTO_ZERO ]
1. 1 sec
2. 10 sec
3. 30 sec
▲ ▼

Japanese

[ 2. オートゼロ ]
1. 1 秒
2. 10 秒
3. 30 秒
▲ ▼

Item			Description
	English	Japanese	
1	1 sec	1 秒	During measurement, when no input pulse status continues for 1 second, the display is turned to 0
2	10 sec	10 秒	During measurement, when no input pulse status continues for 10 seconds, the display is turned to 0
3	30 sec	30 秒	During measurement, when no input pulse status continues for 30 seconds, the display is turned to 0
4	60 sec	60 秒	During measurement, when no input pulse status continues for 60 seconds, the display is turned to 0
	None	無効	Auto zero disabled

Operation key	Operation
Operation key 1	Select the upper item Press and hold for 1 second to move continuously
Operation key 2	Select the lower item Press and hold for 1 second to move continuously
Operation key 3	Enable the selected item, and return to the system settings
Operation key 4	Return to the system settings

### (3-3) Graph display

Set various graph settings.

#### (1) Graph flow

Set the line graph direction.

This setting is enabled only for Graph\_1 (line graph).

English

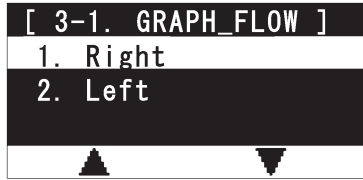

Japanese



Operation key	Operation
Operation key 1	Select the upper item Press and hold for 1 second to move continuously
Operation key 2	Select the lower item Press and hold for 1 second to move continuously
Operation key 3	Go to 3-2
Operation key 4	Return to the system settings

Item		Description
English	Japanese	
1. Right	右方向	Graph update direction: Right
2. Left	左方向	Graph update direction: Left

Graph flow: Right direction



Graph flow: Left direction



#### (2) Graph time

Set the graph time.

This setting is for time width of the graph for Graph\_1 (line graph).

Also, it represents the update time when the measurement display "AVE", "ACC", "P.AVE", or "P.ACC" is indicated.

English

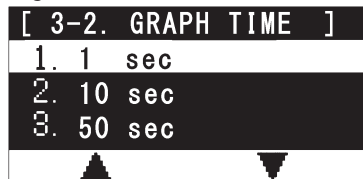

Japanese



Operation key	Operation
Operation key 1	Select the upper item Press and hold for 1 second to move continuously
Operation key 2	Select the lower item Press and hold for 1 second to move continuously
Operation key 3	Go to 3-3
Operation key 4	Return to 3-1

Item		Description	
English	Japanese		
1	1 sec	1 秒	Graph time setting: 1 second
2	10 sec	10 秒	Graph time setting: 10 seconds
3	50 sec	50 秒	Graph time setting: 50 seconds
4	100 sec	100 秒	Graph time setting: 100 seconds

### (3) Graph maximum value

Set the maximum value in the graph display.

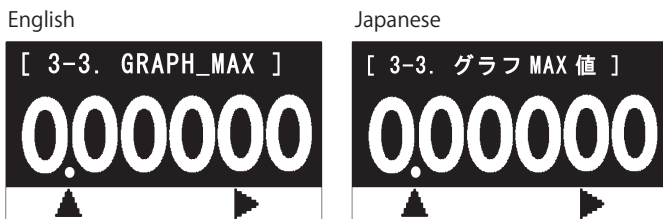

Operation key	Operation	
	When setting the numerical value	When setting the decimal point
Operation key 1	Increases the numerical value in the selected digit. Press and hold for 1 second to increase continuously.	Return to the numerical value setting.
Operation key 2	Moves the digit. Press and hold for 1 second to move continuously.	Moves the decimal point. Press and hold for 1 second to move continuously.
Operation key 3	Go to 3-4.	
Operation key 4	Return to 3-2.	

▲ Go to the first digit of the numerical value setting

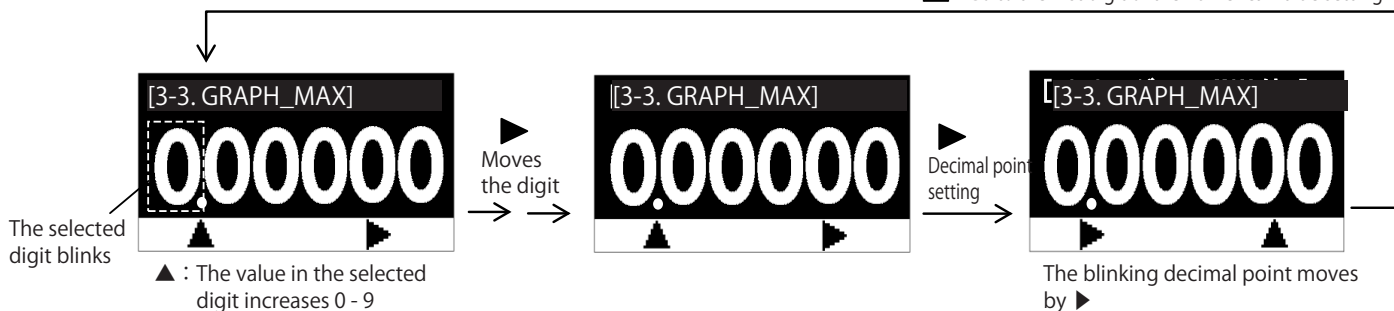

### (4) Graph minimum value

Set the minimum value in the graph display.

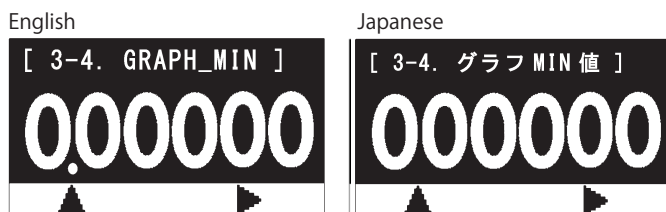

Operation key	Operation	
	When setting the numerical value	When setting the decimal point
Operation key 1	Increases the numerical value in the selected digit. Press and hold for 1 second to continuously increase.	Return to the numerical value setting.
Operation key 2	Moves the digit. Press and hold for 1 second to move continuously.	Moves the decimal point. Press and hold for 1 second to move continuously.
Operation key 3	Enable the setting, and return to the system settings.	
Operation key 4	Return to 3-3.	

▲ Go to the first digit of the numerical value setting

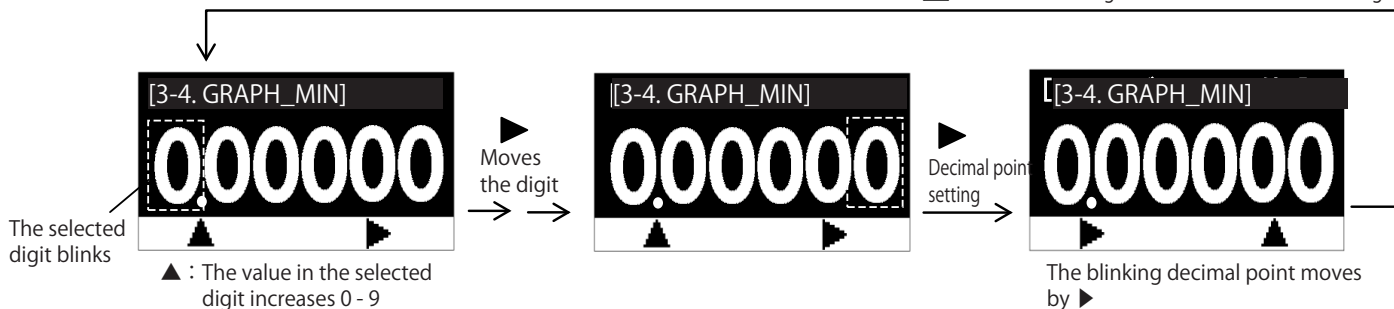

### About the graph maximum/minimum values

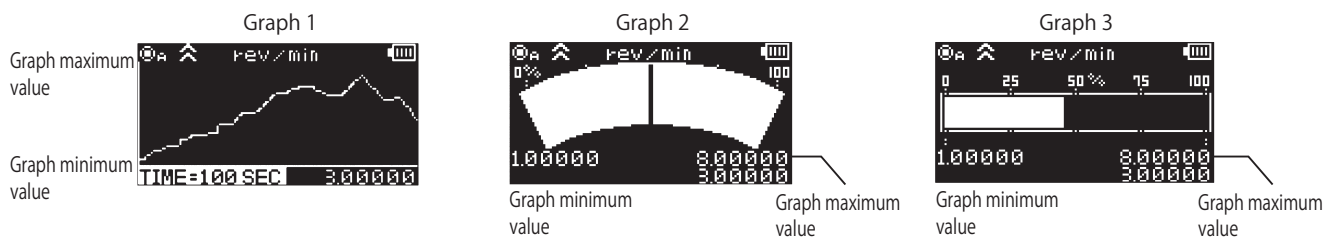

\*Values that represent the graph maximum value  $\geq$  graph minimum value cannot be set.

### (3-4) Memory group

Set the number of memory data registration sets for each memory group.

#### (1) Setting memory group selection

Select the memory group to set.

English

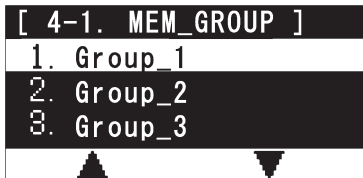

Japanese

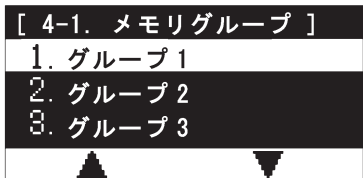

Operation key	Operation
Operation key 1	Select the upper item Press and hold for 1 second to move continuously
Operation key 2	Select the lower item Press and hold for 1 second to move continuously
Operation key 3	Go to 4-2
Operation key 4	Return to the system settings

	Item		Description
	English	Japanese	
1.	Group_1	グループ 1	Go to the setting of memory group 1
2.	Group_2	グループ 2	Go to the setting of memory group 2
3.	Group_3	グループ 3	Go to the setting of memory group 3
4.	Group_4	グループ 4	Go to the setting of memory group 4
5.	Group_5	グループ 5	Go to the setting of memory group 5

#### (2) Group setting

Set the number of memory data registration sets for the memory group selected in (1).

English

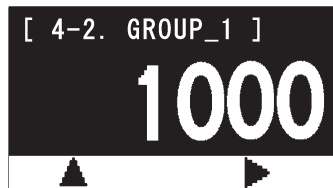

Japanese



Operation key	Operation
	When setting the numerical value
Operation key 1	Select the upper item Press and hold for 1 second to move continuously
Operation key 2	Select the lower item Press and hold for 1 second to move continuously
Operation key 3	Go to delete the registration memory data for each memory group
Operation key 4	Return to 4-1

\*No decimal point setting

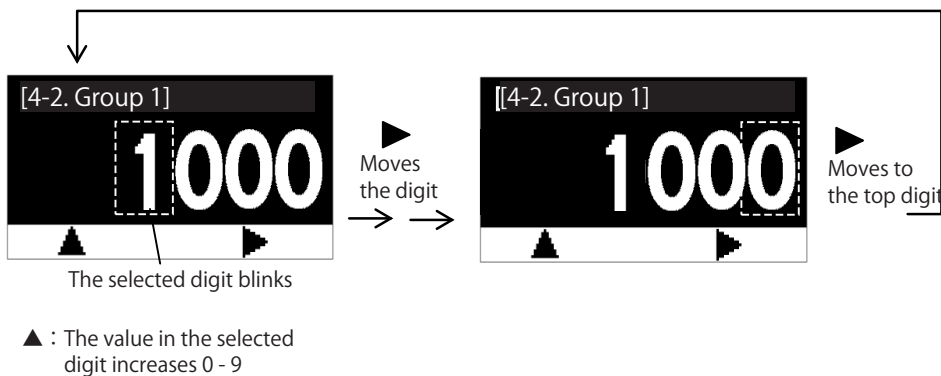

\*Set the value for each memory mode within the setting range in the table below.

\*When the total number of memory data registration sets for memory groups exceeds the maximum value in the table below, it cannot be set.

\*When the total number of memory data registration sets for memory groups is 0, it cannot be set.

\*When changing the memory mode, the setting value of the number of registered memory sets for each memory group ("4. MEM\_GROUP" of "3. SET\_SYSTEM" in contents selection) is initialized to the value that corresponds to the memory mode.

Memory mode	Maximum number of registration sets	Setting range					Setting condition
		Memory group 1	Memory group 2	Memory group 3	Memory group 4	Memory group 5	
Continuous	1000 sets	0 - 1000 (Default value: 1000)	0 - 1000 (Default value: 0)	0 - 1000 (Default value: 0)	0 - 1000 (Default value: 0)	0 - 1000 (Default value: 0)	Set the total number of data sets for memory groups 1 to 5 to be within the maximum number of registration sets
Each	100 sets	0 - 100 (Default value: 100)	0 - 100 (Default value: 0)	0 - 100 (Default value: 0)	0 - 100 (Default value: 0)	0 - 100 (Default value: 0)	
Statistics	100 sets	0 - 100 (Default value: 100)	0 - 100 (Default value: 0)	0 - 100 (Default value: 0)	0 - 100 (Default value: 0)	0 - 100 (Default value: 0)	

## ● Registration memory data deletion in each memory group

When the number of memory data registration sets for each memory group has been changed, the memory data registered in the corresponding memory group needs to be deleted.

English

<b>Group_□ Clear?</b>	
1. No	
2. Yes	
▲ ▼	

Japanese

<b>グループ 1 を消去しますか?</b>	
1. いいえ	
2. はい	
▲ ▼	

Operation key	Operation
Operation key 1	Select the upper item Press and hold for 1 second to move continuously
Operation key 2	Select the lower item Press and hold for 1 second to move continuously
Operation key 3	Execute clear/Return to the number of memory sets setting without executing clear
Operation key 4	Return to the number of memory sets setting

Item			Description
	English	Japanese	
1.	No	いいえ	Registration memory data deletion in the current memory group: not permitted
2.	Yes	はい	Registration memory data deletion in the current memory group: permitted

\*When the registration memory data is not deleted, the number of memory data registration sets in the memory group will not be changed.

## (3-5) Contact/Non-contact

The measurement method can be selected from contact and non-contact. Automatic detection can be also performed.

English

<b>[ 5. CONTACT ]</b>	
1. Contact	
2. Non Contact	
3. Auto	
▲ ▼	

Japanese

<b>[ 5. 接触/非接触 ]</b>	
1. 接触	
2. 非接触	
3. 自動検出	
▲ ▼	

Operation key	Operation
Operation key 1	Select the upper item Press and hold for 1 second to move continuously
Operation key 2	Select the lower item Press and hold for 1 second to move continuously
Operation key 3	Enable the selected item, and return to the system settings
Operation key 4	Return to the system settings

Item			Description
	English	Japanese	
1	Contact	接触	Select when the contact adapter is attached
2	Non Contact	非接触	Select when the contact adapter is not attached
3	Auto	自動検出	Automatic detection mode
4	Contact(Low)	接触 ( 低速 )	Select when the contact adapter for low speed is attached

\*Select "4. Contact (Low)" when using the optional contact adapter for low speed.

\*When "3. AUTO DETECT" is selected, contact attachment may not be automatically detected correctly depending on the environment. In that case, select 1 to 2 manually. In addition, for automatic detection, contact attachment is detected when measurement starts. The measurement value may not be displayed correctly from measurement start to completion of automatic detection.

\*If using a low-speed contact adapter, do not select "3. Auto".

## (3-6) DISP\_CYCLE Display update cycle

The display update cycle of the measurement value can be selected.

The measurement value is updated every time the period of time selected in this setting is reached.

English

<b>[ 6. DISP_CYCLE ]</b>	
1. 100 msec	
2. 500 msec	
3. 1 sec	
▲ ▼	

Japanese

<b>[ 6. 表示更新周期 ]</b>	
1. 100 msec	
2. 500 msec	
3. 1 sec	
▲ ▼	

Operation key	Operation
Operation key 1	Select the upper item Press and hold for 1 second to move continuously
Operation key 2	Select the lower item Press and hold for 1 second to move continuously
Operation key 3	Enable the selected item, and return to the system settings
Operation key 4	Return to the system settings

Item (common to Japanese and English)		Description
1	100msec	Display update cycle: 100msec
2	500msec	Display update cycle: 500msec
3	1sec	Display update cycle: 1sec
4	5sec	Display update cycle: 5sec

\*When the display update cycle has been changed, the measurement value to be displayed may slightly change.

### (3-7) Prescale

The prescale value can be set. Prescale is a user defined mathematical correction of the values displayed. This can be helpful when a scaling of the point measured has more significant meaning to the user taking the measurement. The measurement value display of "PRE", "P.MAX", "P.MIN", "P.AVE", and "P.ACC" is influenced by the prescale value.

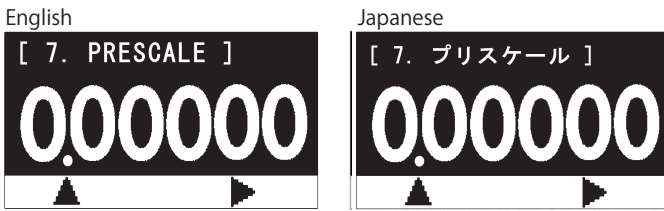

Operation key	Operation	
	When setting the numerical value	When setting the decimal point
Operation key 1	Increases the numerical value in the selected digit Press and hold for 1 second to increase continuously	Return to the numerical value setting
Operation key 2	Moves the digit Press and hold for 1 second to move continuously	Moves the decimal point Press and hold for 1 second to move continuously
Operation key 3	Enable the setting, and return to the system settings.	
Operation key 4	Return to the system settings	

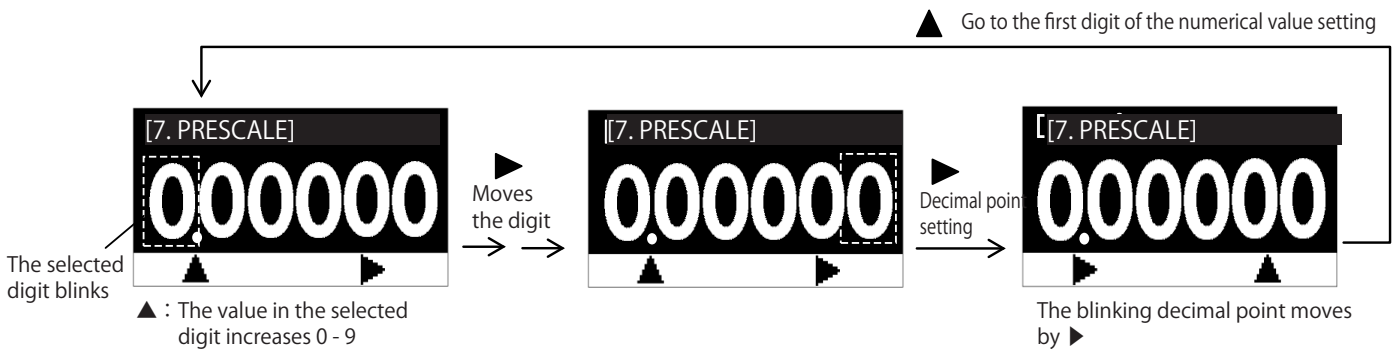

\*The setting range is between 0.00001 and 999999. 0 cannot be set.

#### • About prescale

Set the prescale value to the number of pulses per rotation (for contact measurement, the number of measurement shaft rotations), and perform the following calculation for measurement display

When the measurement value is 100.0,  
and the prescale value is 2.00,  $100.0/2.00 = \text{Display: } 50$

\*The accuracy depends on the measurement value before applying prescale.

### (3-8) Diameter

Set the diameter value of the speed measurement wheel when using the speed measurement in contact measurement.

\*These setting contents are not applied to non-contact measurement.

#### (1) Diameter unit

Set the diameter value unit.

English

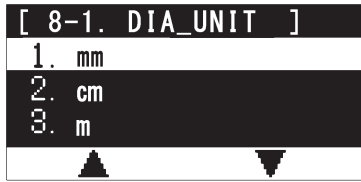

Japanese

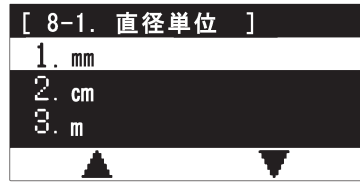

Operation key	Operation
Operation key 1	Select the upper item Press and hold for 1 second to move continuously
Operation key 2	Select the lower item Press and hold for 1 second to move continuously
Operation key 3	Go to 8-2
Operation key 4	Return to the system settings

Item (common to Japanese and English)	Description
1 mm	Diameter unit: mm
2 cm	Diameter unit: cm
3 m	Diameter unit: m
4 inch	Diameter unit: inch
5 feet	Diameter unit: feet
6 yards	Diameter unit: yards

#### (2) Diameter

Set the diameter value.

English



Japanese



Operation key	Operation	
	When setting the numerical value	When setting the decimal point
Operation key 1	Increases the numerical value in the selected digit Press and hold for 1 second to increase continuously	Return to the numerical value setting
Operation key 2	Moves the digit Press and hold for 1 second to move continuously	Moves the decimal point Press and hold for 1 second to move continuously
Operation key 3	Enable the setting, and return to the system settings.	
Operation key 4	Return to 8-1	

▲ Go to the first digit of the numerical value setting

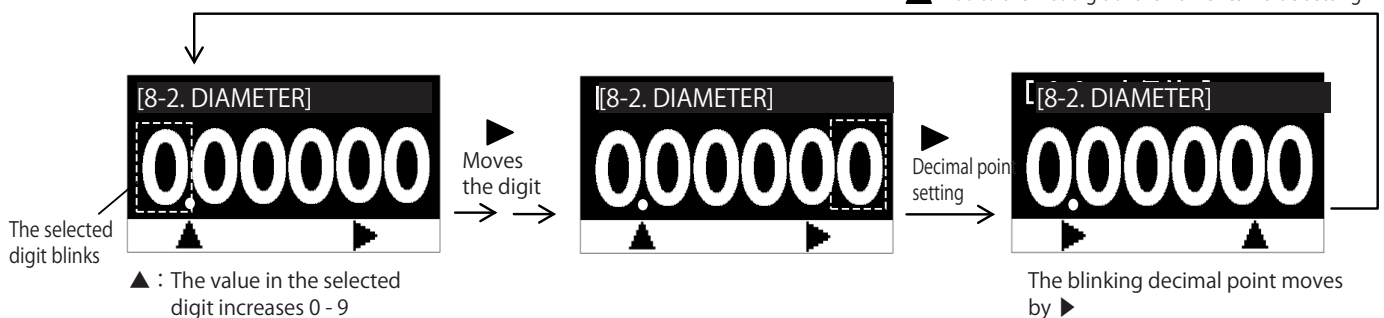

#### • About diameter

From the diameter value of the speed measurement wheel, obtain the distance per rotation of the measurement shaft, and then obtain the peripheral speed and distance. This setting is enabled only when the speed measurement unit (excluding rev/min and rev/sec) and distance measurement unit are selected at the time of contact attachment.

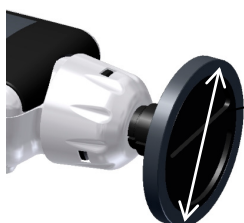

Calculate the circumference distance from the diameter of the speed measurement wheel

### (3-9) Distance/Pulse

Set the distance value per pulse for non-contact measurement.

\*This setting contents are not applied to contact measurement.

#### (1) Distance unit

Set the distance value unit per pulse.

English



Japanese



Operation key	Operation
Operation key 1	Select the upper item Press and hold for 1 second to move continuously
Operation key 2	Select the lower item Press and hold for 1 second to move continuously
Operation key 3	Go to 9-2
Operation key 4	Return to the system settings

Item (common to Japanese and English)	Description
1 mm	Diameter unit: mm
2 cm	Diameter unit: cm
3 m	Diameter unit: m
4 inch	Diameter unit: inch
5 feet	Diameter unit: feet
6 yards	Diameter unit: yards

#### (2) Distance/Pulse

Set the distance value per pulse.

English



Japanese



Operation key	Operation	
	When setting the numerical value	When setting the decimal point
Operation key 1	Increases the numerical value in the selected digit Press and hold for 1 second to increase continuously	Return to the numerical value setting
Operation key 2	Moves the digit Press and hold for 1 second to move continuously	Moves the decimal point Press and hold for 1 second to move continuously
Operation key 3	Enable the setting, and return to the system settings.	
Operation key 4	Return to 9-1	

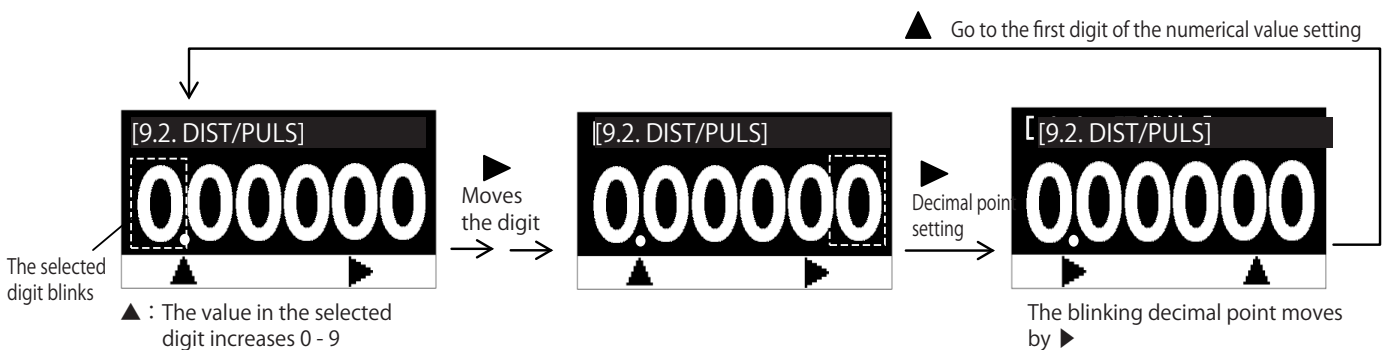

#### • About distance/pulse

Obtain the peripheral speed and distance from the distance value per pulse.

This setting is enabled only when the speed measurement unit (excluding rev/min and rev/sec) and distance measurement unit are selected at the time of contact attachment.

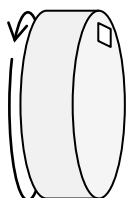

Obtain the peripheral speed and distance from the distance value per pulse.



### (3-10) Brightness

The brightness on the screen can be set.

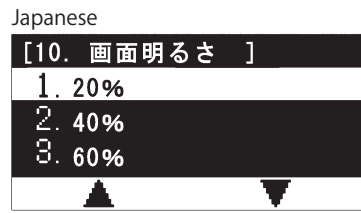
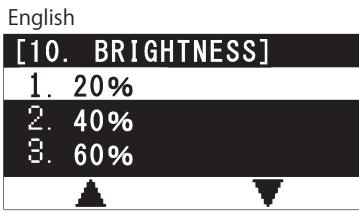

Item (common to Japanese and English)	Description
1 20%	Dark ↑ ↓ Bright
2 40%	
3 60%	
4 80%	
5 100%	

Operation key	Operation
Operation key 1	Select the upper item Press and hold for 1 second to move continuously
Operation key 2	Select the lower item Press and hold for 1 second to move continuously
Operation key 3	Enable the selected item, and return to the system settings
Operation key 4	Return to the system settings

### (3-11) Reverse display

The vertical reverse can be applied to the display items.



Item (common to Japanese and English)	Description
1. OFF	Reverse display OFF
2. ON	Reverse display ON

Operation key	Operation
Operation key 1	Select the upper item Press and hold for 1 second to move continuously
Operation key 2	Select the lower item Press and hold for 1 second to move continuously
Operation key 3	Enable the selected item, and return to the system settings
Operation key 4	Return to the system settings

\*The reverse display is enabled only in the measurement mode (including the graph display).  
For various settings, and memory data display, the reverse display is disabled.

### (3-12) Language

The language to be displayed can be set.



Item (common to Japanese and English)	Description
1. Japanese	Language to be displayed: Changes to Japanese
2. English	Language to be displayed: Changes to English

Operation key	Operation
Operation key 1	Select the upper item Press and hold for 1 second to move continuously
Operation key 2	Select the lower item Press and hold for 1 second to move continuously
Operation key 3	Enable the selected item, and return to the system settings
Operation key 4	Return to the system settings

### (3-13) Measurement switch

The operation mode of the measurement switch can be set.

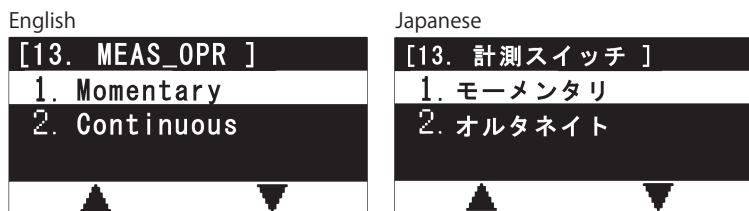

Item		Description
English	Japanese	
1	Momentary	Measures only while the measurement switch is pressed and held
2	Continuous	Starts measurement when the measurement switch is pressed once Ends measurement when it is pressed again

Operation key	Operation
Operation key 1	Select the upper item Press and hold for 1 second to move continuously
Operation key 2	Select the lower item Press and hold for 1 second to move continuously
Operation key 3	Enable the selected item, and return to the system settings
Operation key 4	Return to the system settings

### (3-14) Initialization

The setting value can be initialized.

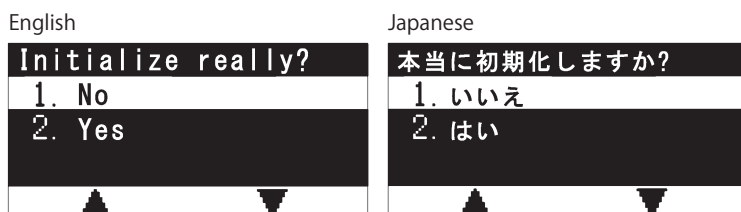

Item		Description
English	Japanese	
1	No	Return to the system settings without initialization
2	Yes	Initializes the setting contents

Operation key	Operation
Operation key 1	Select the upper item Press and hold for 1 second to move continuously
Operation key 2	Select the lower item Press and hold for 1 second to move continuously
Operation key 3	Execute initialization/Return to the system settings without initialization
Operation key 4	Return to the system settings

\*The user setting contents are also initialized.

Note that the contents saved in "User\_Set\_1" to "User\_Set\_3" of "SEL\_USER" in the user settings are not initialized.

### \*Memory registration when the unit, diameter, distance/pulse have been changed

When performing memory registration after the unit, diameter, distance/pulse values have been changed, the already registered memory data needs to be deleted.

If the existing memory data is not deleted, new memory data cannot be registered.

Example: Start memory registration after changing the unit (when memory data is already registered in the start memory group 3, and memory groups 1 to 5)

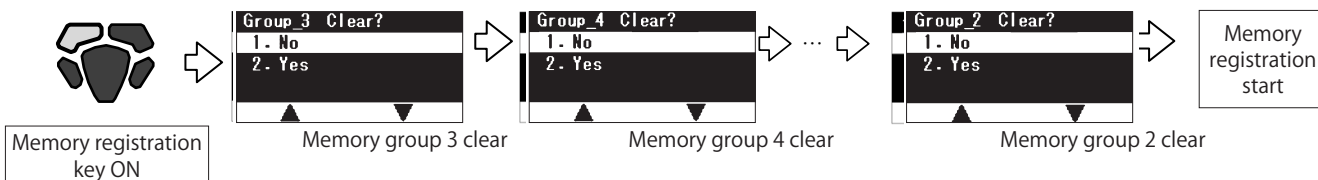

Item		Description
English	Japanese	
1.	No	Memory registration disabled. Return to the measurement mode
2.	Yes	Clears the memory in the current memory group, and moves to next

Operation key	Operation
Operation key 1	Select the upper item Press and hold for 1 second to move continuously
Operation key 2	Select the lower item Press and hold for 1 second to move continuously
Operation key 3	Execute clear/Return to the continuous memory display without executing clear
Operation key 4	Return to the continuous memory display

## 7. Battery Replacement



Replace batteries according to the following procedure.

**1** When the battery level becomes low

Rear panel  
Battery cover



When the battery indicator blinks, open the battery cover on the rear panel, and replace batteries.

**2** Replace with new batteries

Put in two new batteries, aligning the positive and negative polarities correctly, and close the cover.

- Do not mix and use new and old batteries, or different types of batteries.
- Failure to follow this may result in injury and/or damage due to leakage. When you do not use the unit for a long period of time, remove batteries, and keep them in the carrying case.



\*Use AA type alkali or manganese batteries. When other types of batteries are used, operation cannot be guaranteed.

\*In the following cases, the settings and/or memory data may not be saved normally: when the battery level is low, when removing batteries during operation, when disconnecting the USB cable (option) during use at the time of the power supplied only through the USB cable.

## 8. Dimensional Drawing

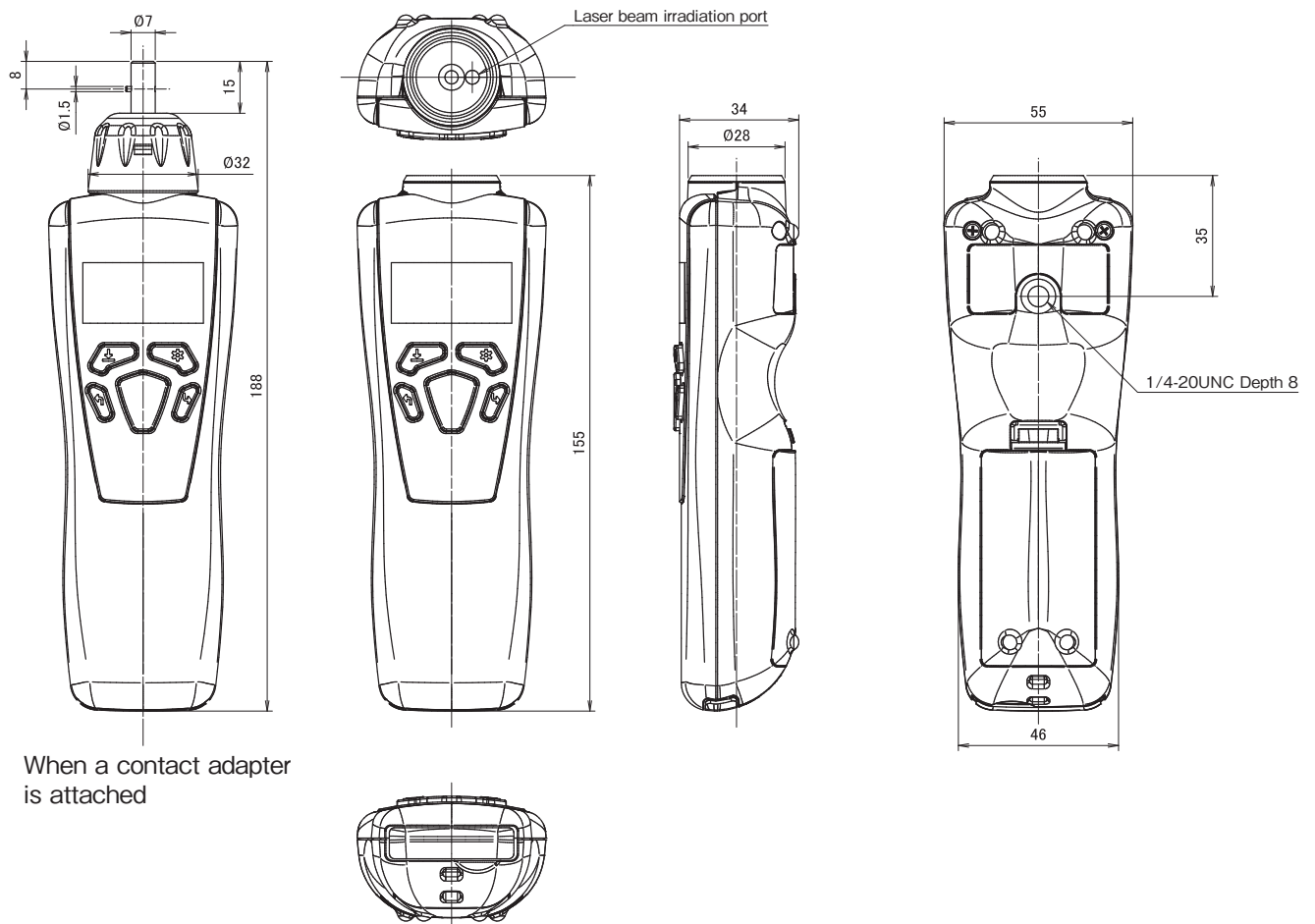

## 9. Specifications

Item	Description
Measurement system	Non-contact Red laser Class2 Maximum output: 1mW Wave length: 650nm
Display	Organic light emitting display (OLED) (blue light emission) graphic display type
Operation switch	5 points
Measurement range	6 to 99,999rpm: Non-contact measurement 0.8 to 25,000rpm: Contact measurement
Measurement unit	Speed measurement: rev/min, m/min, cm/min, inch/min, feet/min, yards/min, rev/sec, m/sec, cm/sec, inch/sec, km/h, miles/h Distance measurement: m, cm, km, inch, feet, yards Manual measurement: STP
Measurement accuracy	unit rev/ min : $\pm 0.006\%$ of the display value, and $\pm 1$ of the least significant digit (Except for display update cycle :100msec & 500msec) • Additional errors in the measurement accuracy may be caused by the measuring environment (hand movement, the angle of the target, etc.). • In the case of contact measurements, errors due to contact slippage or from the measurement wheel may result in additional inaccuracies.
Measurement distance	50 ~ 4,000mm (2 in. to 13 ft.)
Measurement time cycle (display update cycle)	100ms, 500ms, 1sec, 5sec
Functions	Auto off function, memory data registration function, prescale function, peripheral speed wheel diameter setting, comparator function, USB communication, graph display, reverse display, language selection (Japanese/English)
Housing	Polycarbonate resin
Weight	125g
Power supply	AA alkali dry cell battery x 2 (non-charging type), and USB cable (option)
Continuous operating time	Up to 20 hours (when the screen brightness is set to 20%)
Compliance standard	CE, RoHS, PSC, FDA, IEC/EN 60825-1 : 2007
Operating/Storage temperature	0 ~ 40°C (32 to 104 °F) (No condensation)
Accessories	Carrying case, AA alkali dry cell battery x 2, contacts (concave and convex types), contact adapter, speed measurement wheel (circumference of 6 inches), Instruction manual, reflective tape
Option	<ul style="list-style-type: none"> <li>• PC Connect Set (Software, USB Cable)</li> <li>• Contact adapter Set [Contact adapter, 2 cone adapters, 1 funnel adapter, Master wheel (6" Cir.), Extension shaft]</li> <li>• Contact adapter Set (Low) [Contact adapter (Low), 2 cone adapters, 1 funnel adapter, Master wheel (6" Cir.), Extension shaft]</li> <li>• Master wheel (12" Cir.)</li> </ul>

\*Note that applying solvents such as thinner or alcohol, etc. to the main unit may result in the paint peeling and/or damage to the unit.  
Only clean with cloth that is damp from water or water with a mild detergent.

\*Battery maybe have been discharged.

### ● Regarding reflective tape

There are two different types of reflective tape included.  
Use tapes according to the application.

#### ● Standard tape (plain)

For the measurement of close range: 50mm to 1,000 mm.

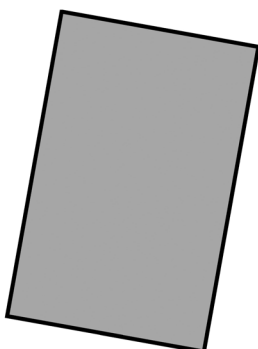

#### ● High intensity reflective tape (grid pattern)

For longer distance, or other cases when the measurement doesn't go through with the standard tape.

