



The M5-2-COF coefficient of friction (COF) gauge is an integral part of a COF testing system, typically including a motorized test stand and COF fixture. With a capacity of 2 lbf [10 N], the gauge can be used to measure friction for a wide range of materials, ideal for conformance to ASTM D1894 and other relevant standards. Static and kinetic coefficients are displayed on the backlit LCD, and are calculated from a user-programmable sled weight.

Data can be transferred to a PC or data collectors via USB, RS-232, Mitutoyo (Digimatic), or analog outputs. On-board memory for up to 1,000 readings is included, as are statistical calculations with output to a PC. Integrated set points with indicators and outputs are ideal for pass-fail testing and for triggering external devices such as an alarm, relay, or test stand. Configurable password protects against unauthorized changes to settings.

The M5-2-COF may also be used for a number of common tension and compression testing applications. The gauge is based on Mark-10's Series 5 advanced digital force gauges, and includes the series' full set of functions and settings.

The M5-2-COF includes MESUR™ Lite data acquisition software. MESUR™ Lite tabulates continuous or single point data. Data saved in the gauge's memory can also be downloaded in bulk. One-click export to Excel easily allows for further data manipulation.



Shown with an ESM303 test stand and G1086 COF fixture

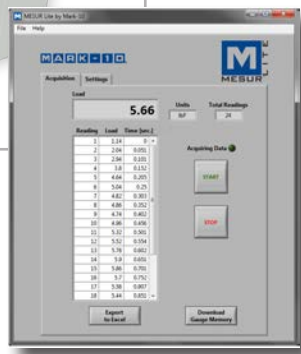

MESUR™ Lite data acquisition software is included with the M5-2-COF

Features

- Calculates static and kinetic coefficients of friction
- Configurable sled weight (100 - 1000 g)
- USB, RS-232, Mitutoyo, and analog outputs
- 1,000-point data memory with statistics and outputs
- Programmable set points, with indicators and outputs
- Live load bar graph with set point markers
- Configurable audio alarms and key tones
- Password protection, configurable for individual keys and calibration

Display Indicators

- Set points →
- Pass/fail indicators →
- Battery indicator →
- Number of saved data points →

- Tension / Compression Indicator
- Compression peak reading
- Static COF (tension peak reading)
- Kinetic COF (when in Averaging mode)
- Measurement mode
- Units of measurement
- Analog load bar w/set point markers

Configurable Sled Weight



The COF is calculated based on the sled weight, adjustable from 100 to 1,000 g, to conform to various standards. A password can be set to protect settings from unauthorized changes.

Specifications

| | |
|------------------------------------|---|
| Capacity x Resolution: | 5 x 0.001 COF*, 2 x 0.0005 lbf, 32 x 0.01 ozF, 1 x 0.0002 kgF, 1000 x 0.2 gF, 10 x 0.002 N |
| Accuracy: | ±0.1% of full scale |
| Sampling Rate: | 7,000 Hz |
| Power: | AC or rechargeable battery. Multi-step low battery indicator is displayed, gauge shuts off automatically when power is too low. |
| Battery life: | Backlight on / off: up to 7 / 24 hours of continuous use |
| Outputs: | USB / RS-232: Configurable up to 115,200 baud. Includes Gauge Control Language 2 for full computer control. Mitutoyo (Digimatic): Serial BCD suitable for all Mitutoyo SPC-compatible devices. Analog: ±1 VDC, ±0.25% of full scale at capacity, General purpose: Three open drain outputs, one input. Set points: Three open drain lines. |
| Safe overload: | 150% of full scale (display shows "OVER" at 110% and above) |
| Weight: | 1.0 lb [0.45 kg] |
| Included items: | Carrying case with chisel, cone, V-groove, hook, flat, extension rod, universal voltage AC adapter, battery, quick-start guide, USB cable, resource CD (USB driver, MESUR™ Lite software, MESUR™ gauge DEMO software, and user's guide), and NIST-traceable certificate of calibration with data. |
| Environmental requirements: | 40 - 100°F, max. 96% humidity, non-condensating |
| Warranty: | 3 years (see individual statement for further details) |

* Depends on the sled weight. For a 200 g weight, the COF capacity is 5. COF resolution is fixed at 0.001.

Specify model M5-2-COFE for euro plug (220V), M5-2-COFU for UK plug (220V) or M5-2-COFA for Australian plug (220V).

Dimensions in [mm]

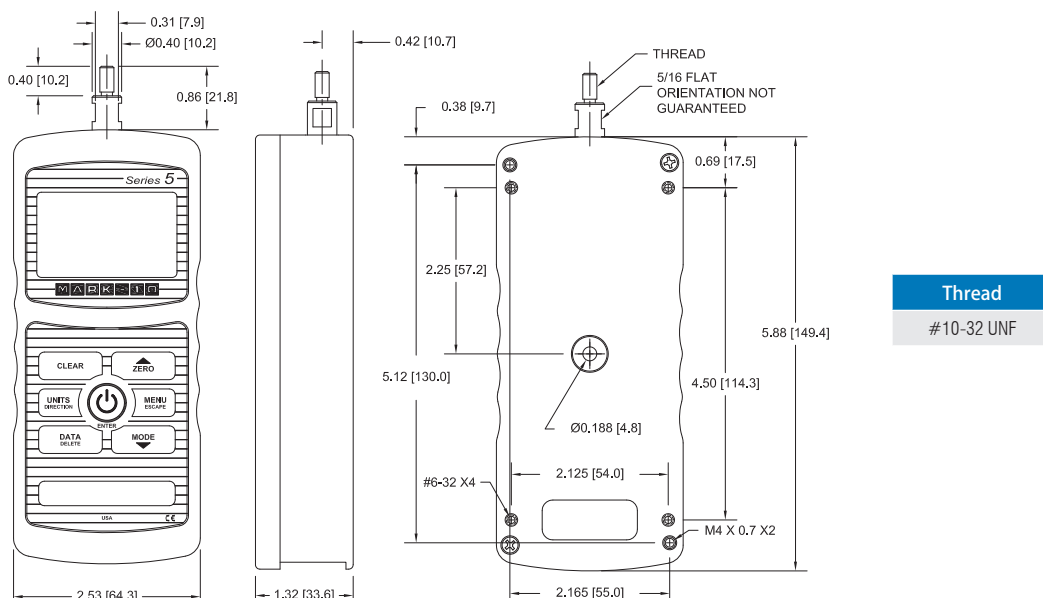

Thread
#10-32 UNF