

Note 'A': Mounting Instruction

1. Use Socket Head Cap Screw for mounting QC
2. Bolt Size: 3/8-16 SHCS
3. Secure into threaded plate: 1" thick for aluminum plate, 0.5" minimum for steel plate.
4. For thru hole mounting in a wooden bench, bench thickness should be 3/4" thick minimum. Use a backing washer as shown.
5. Maximum capacity is 500 lb. ft.
6. QC should never be mounted directly on a wooden bench top. Use of a sub plate of at least 3/8" thick with a 6' x 9' foot print is recommended.
7. Disclaimer: the above instructions are intended as guidelines only. AWS bears no liability for failure of product when mounted to any bench or apparatus not supplied by AWS, Inc.

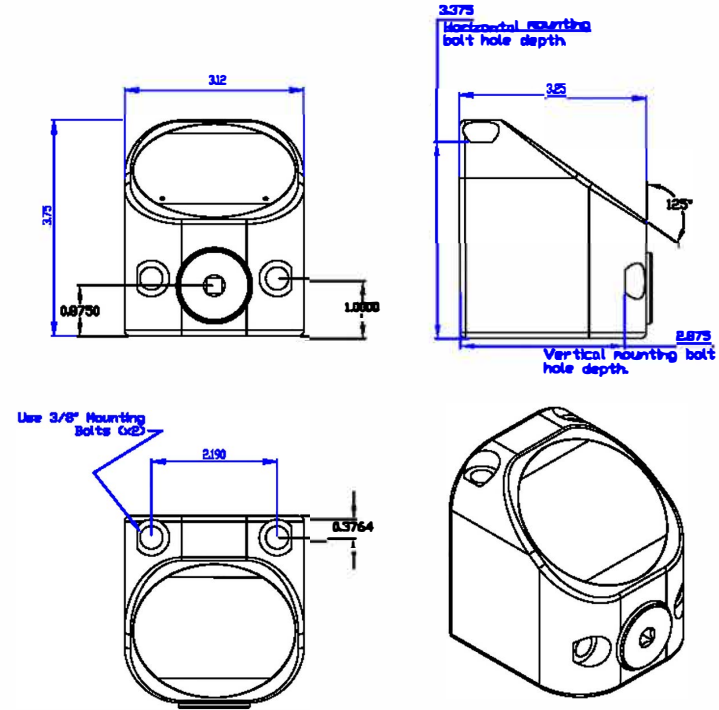

Advanced Witness Series, Inc.	
Rev B, Add Mtg. Plate	QC Outline Dims & Mounting
CRV	
500 Lb. Ft.	1-1-2009
	QC/QC reference dims.dwg