



**CDI “LOGIC[®]” SERIES GAGE TECHNICAL INTERFACE
MANUAL**

**PREPARED BY:
Chicago Dial Indicator Co.
1372 Redeker Road
Des Plaines, IL 60016
Tel. (847) 827-7186
Fax. (847) 827-0478
Website: dialindicator.com**

REVISION 6/18/98

TABLE OF CONTENTS

GAGE INTERFACE CAPABILITIES SUMMARY	3
GAGE DATA OUTPUT OPTIONS:	
HOW TO SEND GAGE DATA TO A CDI FORMAT DEVICE	4
HOW TO SEND GAGE DATA TO A RS232 DEVICE (Including IBM PC)	6
HOW TO SEND GAGE DATA TO A MITUTOYO FORMAT DEVICE	8
HOW TO SEND GAGE DATA TO A CDI REMOTE DISPLAY OR HOW TO ACCESS RAW GAGE QUADRATURE COUNTING PULSES	10
GAGE REMOTE CONTROL AND REMOTE POWER SUPPLY OPTIONS:	
HOW TO REMOTELY CONTROL GAGE "HOLD" FUNCTION	11
HOW TO REMOTELY CONTROL GAGE "ON/CLR" FUNCTION	11
HOW TO USE A NON-CDI EXTERNAL POWER SUPPLY TO POWER GAGE THROUGH DATA PORT	11
HOW TO USE A NON-CDI EXTERNAL POWER SUPPLY TO POWER GAGE THROUGH GAGE POWER MINI-JACK	11
GAGE HARDWARE INTERFACING TECHNICAL DETAILS	12
DATA I/O CONNECTOR STRAPPING AND PIN FUNCTION CHART	14
TROUBLESHOOTING PROBLEMS AND SOLUTIONS	15
CABLE DRAWINGS:	
CDI DATA OUTPUT CABLE	17
RS232 DATA OUTPUT CABLES	18
MITUTOYO DATA OUTPUT CABLE	19
CDI ACCESSORY PRODUCT CATALOG	20

GAGE INTERFACE CAPABILITIES SUMMARY

"LOGIC[®]" SERIES GAGE INTERFACE FEATURES

The CDI gage Data I/O Port is now a multifunctional interface that provides the following features:

1. A "Plug And Play" style automatic configuration for several data output formats.
2. The ability to control remotely, certain gage front panel key functions.
3. Powering of the gage by means of an external non-CDI power supply.
4. Combinations of the above three items.

IMPROVEMENTS OVER OLDER DPX1000 SERIES

Although the "Logic[®]" indicator is similar in many respects to the now obsolete DPX1000 series, it has many more features, including a greatly enhanced Data I/O port, supporting not only the CDI data format, but also RS232 and Mitutoyo formats. Note that the CDI format has also been enhanced to include "error" warnings; also due to the large number of possible gage configurations and applications, the decimal point information has necessarily been changed. The data port is self configuring, i/e, the gage determines which data format to use by scanning the data port interface cable, at gage power up, for jumper straps (see section "DATA I/O CONNECTOR STRAPPING AND PIN FUNCTION CHART" for details).

The I/O port also supports:

- *1. External power supply input (5v, regulated).
- *2. External "ON/CLR"
3. External "HOLD".

*(NOTE: the external power supply and external "ON/CLR" features use the same gage data I/O connector line, and therefore cannot normally be used simultaneously.)

HOW TO SEND GAGE DATA TO A CDI FORMAT DEVICE

HARDWARE SET UP

Connect a CDI data format type cable between the gage and a device capable of receiving CDI format data (order CDI # G13-0034 cable, or see "CDI DATA OUTPUT CABLE" section of this manual for cable construction details).

CONFIRMING AUTOMATIC DATA OUTPUT FORMAT SELECTION

If there are no strap connections between data I/O connector pin 1 and pins 2,3,4, or 5; the gage will automatically go into CDI format data output mode at gage power up. To verify this gage mode press the key sequence "MOVE/2ND", "ON/CLR", and "MOVE/2ND"; and observe "cdi" display. If any other display is observed go to "TROUBLESHOOTING PROBLEMS AND SOLUTIONS" section of this manual.

CDI DATA FORMAT DETAILS

The CDI data format gage output is a continuous, no handshake, clocked output, in packet sets of eight four-bit nibbles. The first four-bit nibble of each gage reading is a non-BCD sync/control nibble; the last seven four-bit BCD nibbles represent the gage reading.; the 2nd nibble is the most significant digit, while the 8th nibble is the least significant digit. The sync/control non-BCD first nibble allows the receiving device to synchronize properly to the eight nibble continuously broadcast data packets; the first nibble is also used to provide certain non-digit information as follows:

	<u>DCBA</u>	<u>HEX</u>	
For "units" mode 1 "+" =	1110	E	(usually "IN")
For "units" mode 1 "-" =	1100	C	"
For "units" mode 2 "+" =	1111	F	(usually "MM")
For "units" mode 2 "-" =	1101	D	"
For ANY Error mode =	1010	A	
For "units" mode 3 "?" =	1011	B	

SIGNAL TIMING

The clock signal out of the CDI gage is a continuous square wave, 1500 Hz, +/- 20% tolerance, 50% duty cycle. Data is valid during full clock strobe cycle; however data and clock strobe (rising) edges are coincident, therefore it is recommended that the falling edge of strobe be used to "latch" data into external data reading systems. A strobe clock stream with a typical valid data period is shown below:

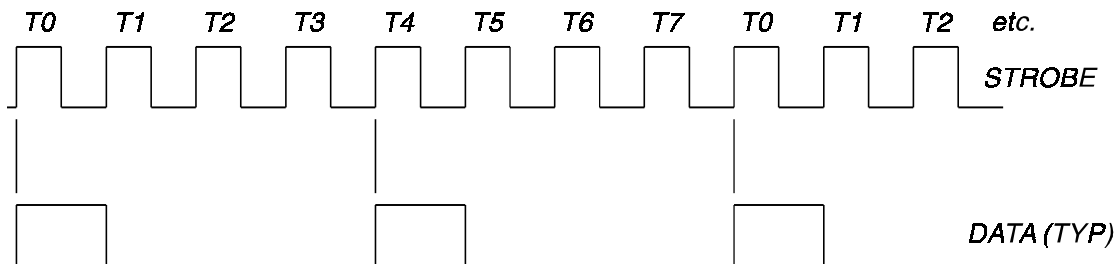

HOW TO SEND GAGE DATA TO A CDI FORMAT DEVICE (con't)

DECIMAL POINT DETERMINATION BY RECEIVING DEVICE

The “LOGIC[®]” series of gages can be set by the user to a number of different resolutions, therefore it is not practical for the CDI Data format to provide decimal point location information - this must be provided by the hardware that is reading the data. External hardware should set the decimal points as follows:

For **INCHES**: 5 decimal places for “LOGIC[®]” gages set at all resolutions, from .00005 to .001; for example, if gage is in .0001 resolution, data output will be .00010; for .001 resolution, data output will be .00100; least digit (digits) will not move, and must be blanked or ignored.

For **MM**: 4 decimal places for “LOGIC[®]” gages set at all resolutions. As for inches, least digits must be blanked or ignored. Example, gage in .001 resolution mode, output will be .0010; for .01 mode, output will be .0100.

NOTE: CDI data output format supports 3 "units" modes, but will output only numerical information only for the third mode, therefore "+" / "-" information for the third mode is not supported.

HOW TO SEND GAGE DATA TO A RS232 DEVICE (Including IBM PC)

HARDWARE SET UP

Connect a RS232 data format type cable between the gage, and a device capable of receiving gage RS232 format data (order CDI #G03-0018 cable for gage to IBM PC, CDI #G03-0021 for gage to a CDI or Utronics printer, CDI #G03-0034 for gage to "SQC/SPC" printer, or see "RS232 DATA OUTPUT CABLES" section of this manual for cable construction details).

CONFIRMING AUTOMATIC DATA OUTPUT FORMAT SELECTION

If there is a strap connection between data I/O connector pin 1 and pin 5; the gage will automatically go into RS232 data output mode on gage power up. To verify this mode press the key sequence "MOVE/2ND" , "ON/CLR", and "MOVE/2ND"; and observe "RS232" display. If any other display is observed go to "TROUBLESHOOTING PROBLEMS AND SOLUTIONS" section of this manual. In addition to the strap between pin 1 and 5, there is also a strap option between pin 1 and pin 4, if this strap is present all gage transmitted RS232 bytes will include even parity (note: all factory built CDI cables are shipped with parity disabled, unless specially ordered otherwise).

HOW TO CAUSE THE GAGE TO BROADCAST A READING TO A RS232 RECEIVING DEVICE

A data packet is sent from the gage to the RS232 device every time gage I/O connector pin 3 (gage "RXD" when gage is strapped for RS232 mode) is pulled low. There are two ways, using a factory supplied cable, to pull this gage line low thus initiating a gage to RS232 device 14 byte packet transfer: the first method is by sending any character from the RS232 device to the gage (activity from RS232 device Txd (DB25 pin 2) through cable conversion circuitry to gage Rxd (gage I/O connector pin 3) is what triggers a gage output); the second method is to connect an external read request switch between pin 3 (Rxd) of the gage I/O connector, and pin 7 (ground) of the same connector (note this method can be employed with any of the three styles of CDI factory produced RS232 cables).

RS232 DATA FORMAT DETAILS

Communication parameters are 1200 Baud, No Parity, 8 Bits, 1 Stop Bit (standard factory cables) or; 1200 Baud, Even Parity, 7 Bits, 1 Stop Bit (special order factory cables). Output data is in ASCII form, sent in left to right format, as if typed in from a keyboard. The gage RS232 data packet consists of 14 ASCII characters divided into the following fields:

Character one "validation character":

- ">" - indicates valid measurement.
- "H" - indicates that reading is out of tolerance (high).
- "L" - indicates that reading is out of tolerance (low).
- "X" - indicates that gage is in any error mode.
- "P" - indicates that gage is in a setting or non-measurement mode.

Character two "sign character":

- "," - indicates a negative reading.
- " " - (space) indicates a positive number, or a pad character for an error display.

HOW TO SEND GAGE DATA TO A RS232 DEVICE (con't)

Characters three through ten are digit/decimal characters:

For IN -"n.nnnn" (n=0 through 9, or space if leading zero).

For MM-"nn.nnn" (n=0 through 9, or space if MOST SIGNIFICANT leading zero).

Character eleven is always “,”.

Characters twelve and thirteen “units field”:

“IN” -for English units.

“MM”-for Metric.

Character thirteen is always a “CR” (carriage return).

Examples Of Complete Data Packets (in Examples, ^ = <SPC>):

Reading Examples:

(For IN +) >^^^^.0000,IN<CR>

(For MM +) >^^^^0.000,MM<CR>

(For IN -) >-.^^^.0000,IN<CR>

(For MM -) >-.^^^0.000,MM<CR>

Error Examples:

X^^Error^n,^^<CR> (“n”=error number).

HOW TO SEND GAGE DATA TO A MITUTOYO FORMAT DEVICE

REQUIREMENT OF PROPER CDI GAGE FOR MITUTOYO DATA MODE

CDI ships some gages with more than 2 "units" modes available, or with units which are not “IN” or “MM”. MITUTOYO data receiving devices will accept only "IN" or "MM"; results for any other units of measure will be unpredictable.

HARDWARE SET UP

Connect a Mitutoyo data format type cable between the gage, and a device capable of receiving gage Mitutoyo format data (order CDI #G03-0019, or see MITUTOYU OUTPUT CABLE" section of this manual for cable construction details).

CONFIRMING AUTOMATIC DATA OUTPUT FORMAT SELECTION

If there are is a strap connection between data I/O connector pin 1 and pin 4, the gage will automatically go into Mitutoyo data output mode at gage power up. To verify this mode press key sequence "MOVE/2ND" , "ON/CLR", and "MOVE/2ND"; and observe "SEr" display. If any other display is observed go to "TROUBLESHOOTING PROBLEMS AND SOLUTIONS" section of this manual.

MITUTOYO DATA FORMAT DETAILS

The Mitutoyo data packet consists of 13 4-bit words (d1) through (d13), each data word is in 4 bit HEX format, sent least significant first as follows:

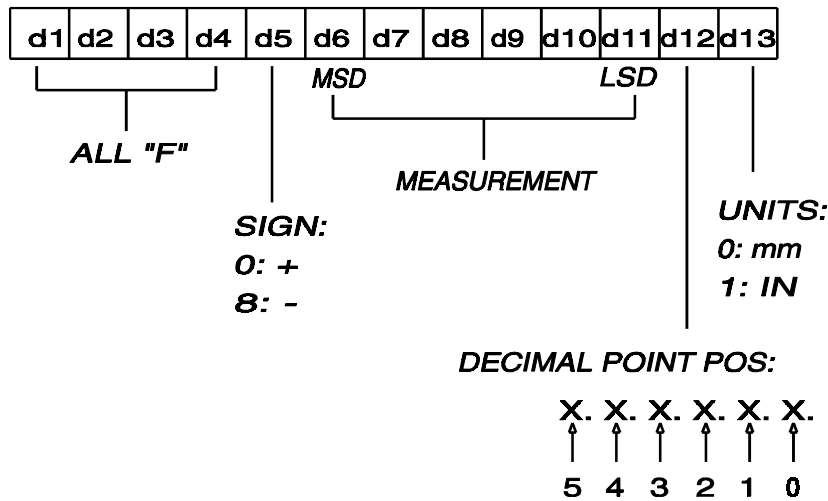

EXAMPLE: +1.00025 IN

d1	d2	d3	d4	d5	d6	d7	d8	d9	d10	d11	d12	d13
F	F	F	F	0	1	0	0	0	2	5	5	1

HOW TO SEND GAGE DATA TO A MITUTOYO FORMAT DEVICE (con't)

Mitutoyo Data Timing

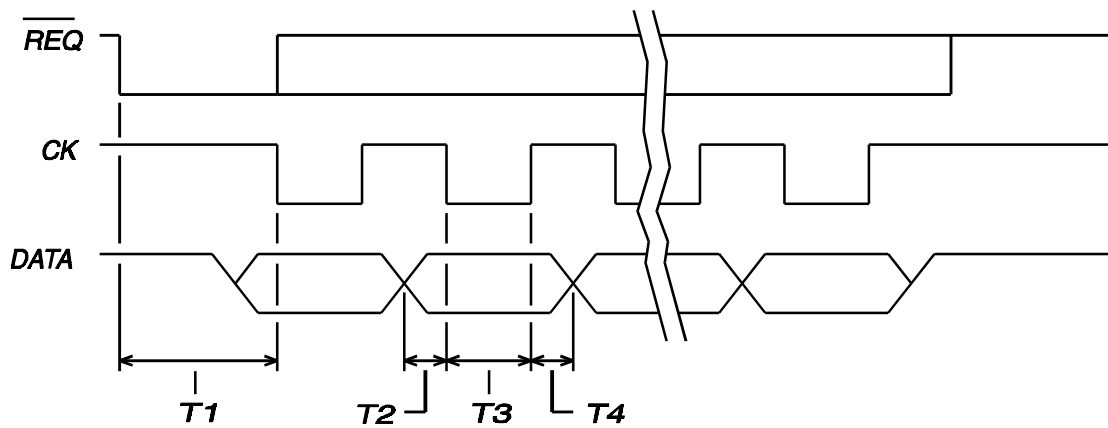

Timing Specifications:

1. \overline{REQ} (request) duration: hold low until falling edge of clock occurs.
2. T1 limits: >200mS, <2 Sec.
3. T2 limits: >200uS, <400uS.
4. T3 limits: >500uS, <1000uS.
5. T4 limits: >200uS, <400uS.

HOW TO SEND GAGE DATA TO A CDI REMOTE DISPLAY OR HOW TO ACCESS RAW GAGE QUADRATURE COUNTING PULSES

HARDWARE SET UP STANDARD GAGE DRIVING CDI REMOTE DISPLAY

A CDI remote display can be driven by a by a standard gage who's data output is strapped for raw quadrature output pulses. To use a standard gage as the input to a CDI remote display, use a gage to remote cable assembly (CDI #G03-0022). Note that the strap for this gage data output mode is located in the CDI remote display enclosure, not in the cable; therefore gage must be connected to the cable, and the remote display box, for the proper gage data output mode to be entered at power up.

Note also that the base resolution of the gage must match that of the remote display to be used, i/e - only a .00005 base resolution gage can be connected to a .00005 base resolution display, etc. Remote displays and gages are available in both .00005 and .0001 standard base resolutions.

HARDWARE SET UP ACCESSING RAW QUADRATURE COUNTING PULSES

By connecting an appropriately strapped cable between the gage and quadrature receiving device, much of the intelligence, and front panel control, of the CDI "LOGIC"® gage can be bypassed, and the gage's raw counting pulses can be accessed. Using CDI # G13-0034 cable (or see "CDI FORMAT DATA OUTPUT ASSEMBLY" section of this manual for cable construction details) strap pins 1 (brown wire) to pin 3 (orange wire) for mode control, and take quadrature outputs from pins 4 and 5 (yellow and green wires).

The two quadrature pulse trains are proportional to spindle movement, and the number of pulses per measurement unit are a factory set constant. The phase relationship of the two quadrature waves indicates spindle direction. There is no handshake protocol involved with gage raw quadrature pulse output mode, the pulses simply appear when the spindle is moved.

CONFIRMING AUTOMATIC DATA OUTPUT FORMAT SELECTION

If there is a strap connection between data I/O connector pin 1 and pin 3, the gage will automatically go into raw quadrature output mode on gage power up and "bp" should be displayed on LCD. If any other display is observed go to "TROUBLESHOOTING PROBLEMS AND SOLUTIONS" section of this manual.

HOW TO REMOTELY CONTROL GAGE "HOLD" FUNCTION

By connecting a mechanical switch, or an open collector transistor, from gage data I/O pin 6 to ground, the "HOLD" key function on the gage keyboard can be activated. Grounding this line by mechanical or solid state means has the exact same effect as a push of the gage "HOLD" button. This remote function is actuated on the release of the ground connection to pin 6, not a continuous grounding of pin 6 (note: a pin 6 to ground hold time minimum of hold of 120ms is required before the ground to pin 6 connection is opened).

The blue wire, pin 6, of a CDI data format type cable (signal ground is the black wire, pin 8) can be used for remote "HOLD" purposes (order CDI # G13-0034 cable, or see "CDI FORMAT DATA OUTPUT ASSEMBLY" section of this manual for cable construction details).

HOW TO REMOTELY CONTROL GAGE "ON/CLR" FUNCTION

By connecting a mechanical switch, or an open collector transistor from gage data I/O pin 7 to ground, the "ON/CLR" key function on the gage keyboard can be activated. Grounding this line by mechanical or solid state means has the same effect as a push of the gage "ON/CLR" button, but only when the gage has been turned on by the "ON/CLR" button. (NOTE: pin 7 of the gage data I/O connector can also be used for an external power supply as described in the next section. If pin 7 is used for a external power supply no attempt should be made to also have a remote "ON/CLR" switch, as this will cause a short circuit to the external power supply.)

The violet wire, pin 7, of a CDI data format type cable (signal ground is the black wire, pin 8) can be used for remote "ON/CLR" purposes (order CDI # G13-0034 cable, or see "CDI FORMAT DATA OUTPUT ASSEMBLY" section of this manual for cable construction details).

HOW TO USE A NON-CDI EXTERNAL POWER SUPPLY TO POWER GAGE THROUGH DATA PORT

The CDI "LOGIC[®]" gage can be powered by batteries, a CDI AC adapter through gage mini-jack, a non-CDI AC adapter through gage mini-jack, or an external power supply connected to the data I/O port. The external power supply must be between 4.9 and 5.5 volts DC, and have minimal ripple or noise. When powering the gage through the gage data port, pin 7 of the gage data I/O connector (violet wire of a CDI data format type cable) is power input, and signal ground is pin 8 (black wire of a CDI data format cable); order CDI # G13-0034 cable, or see "CDI FORMAT DATA OUTPUT ASSEMBLY" section of this manual for cable construction details.

Note that the external power supply uses the same data I/O pin (pin 7) as is used for the remote "ON/CLR" function; if the remote "ON/CLR" function is desired it is recommended that a CDI AC adapter (G11-0012) be used which has it's own dedicated connector jack on the gage.

HOW TO USE A NON-CDI EXTERNAL POWER SUPPLY TO POWER GAGE THROUGH GAGE MINI-JACK

The CDI "LOGIC[®]" gage can be powered by a non-CDI AC adapter through the gage's power input mini-jack. The external supply must provide a loaded voltage of 7.5 to 11 volts DC (9 volts nominal), at a current minimum of 30 milliamps per gage load. The unloaded power supply voltage should not exceed 20 volts DC. The polarity of the mini-plug from the power supply is center plus, as shown in the drawing below:

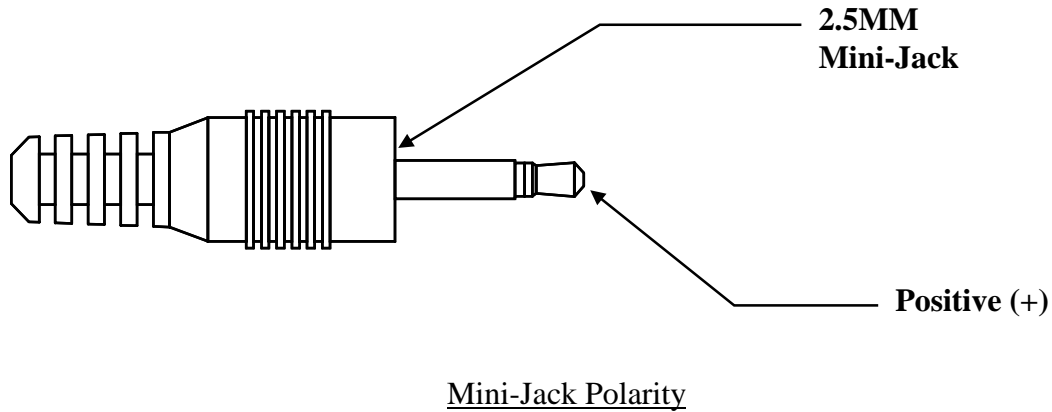

GAGE HARDWARE INTERFACING TECHNICAL DETAILS

SELF CONFIGURING DATA OUTPUT MODE OPERATION

The CDI Data I/O Port connector consists of eight conductors and a shield. Pins 1 through 5 are dedicated to data output, pin 6 is for remote “HOLD”, pin 7 is for remote “ON/CLR” or an external power supply, and pin 8 is the signal ground. Various combinations of pins 2 through 5 are tied to pin 1 to force gage data output mode self configuration during power up. During gage power up: a low going signal is sent out on pin 1, the gage then reads pins 2 through 5, any of these four pins that are read low are considered strapped to pin 1 by the gage, the gage data output mode corresponding to the strap code is then automatically entered and retained until power is removed from the gage (See "DATA CONNECTOR STRAPPING AND PIN FUNCTION CHART" for specific strap positions and their meaning). To verify data output mode press key sequence "MOVE/2ND" , "ON/CLR", and "MOVE/2ND", and observe display. If the display indicates that a erroneous data output mode has been entered in contradiction to the cable strap settings refer to the section below.

AVOIDING INTERFACE PROBLEMS CAUSED BY READING DEVICE LOADING

User data receiving circuitry that is tied to gage pins 2,3,4, &5 must not interfere with the strap reading function that occurs at gage power up. Two receiving device error conditions must be avoided if proper strap reading by the gage is to occur: 1. receiving devices (powered or unpowered) cannot present an impedance from pins 2,3,4, or 5 to ground that interferes with the approximately one megohm pull-up resistors that are internal to the gage (these resistors cause an unstrapped pin to be read high); and 2. , powered receiving devices cannot present an impedance from pins 2,3,4, or 5 to a positive voltage that prevents gage pin 1 from driving a strapped pin low (pin 1 drives the strap through a internal one kilohm series resistor).

If the above mentioned conditions are violated problems can be encountered entering proper gage data output modes when “LOGIC[®]” gages are connected to reading devices which have not been turned on, or which have lower than expected load impedances. In some cases, by connecting cabling to the gage first, turning the gage on, and then connecting the cable to the reading device, a strap reading conflict can be avoided. A better method is to employ the circuit shown below, when interfacing from pins 2,3,4, or 5 to a reading device; if this circuit is used the gage can be turned on whether the reading

device is on or off, and the strap reading will be still be correct. Note that CDI factory built cables for MITUTOYO and RS232 have this correct interface circuitry in them.

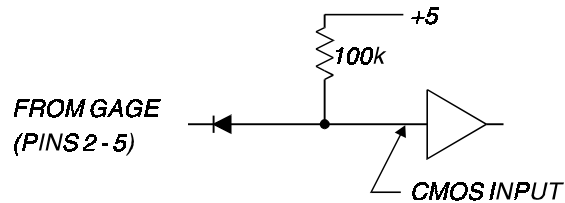

SUGGESTED INTERFACE CIRCUIT DESCRIPTION

High impedance (=> 100k), returned to +5V, on all lines connected to pins 2 through 5 of the data I/O connector at gage (red, orange, yellow, green wires of CDI G13-0034 cable). With lower impedance loads, the data output may function, but will cause heavier loading of the internal gage batteries, resulting in shortened gage battery operating life. Diode isolation should be added to prevent inadvertent "misreading" of cable strapping when reading device has not yet been turned on.

OUTPUT DRIVING CHARACTERISTICS OF GAGE DATA I/O CONNECTOR LINES

Pin 1 of the gage data I/O connector is always an output, and pins 2,3,4, & 5 are bi-directional. When any data line is in an output mode it's driving characteristics are approximately the same as a standard CMOS 4000 series gate, with an approximately 5 volt supply driving through a series 1K resistor.

GROUNDING AND SHIELDING

In most cases the user need not be concerned with taking any special measures regarding shielding or grounding. All cables connecting the gage data I/O port to data receiving equipment must include a signal ground, which provides a voltage reference to the circuitry on both ends. A shield line is also present, in all CDI factory produced cables, at the gage side of the data I/O connector, which is in common with the case of the gage. Normally a shield should be included in any cable attached to the gage I/O connector, and should be tied to the gage side only. If noise problems occur (usually indicated by an "ERROR 1" display on the gage) experiments can be attempted that ground both sides of the interface cable shield.

DATA I/O CONNECTOR STRAPPING AND PIN FUNCTION CHART

GAGE DATA I/O CONNECTOR STRAPPING AND PIN FUNCTION CHART-REVISION 2/11/97										
PIN NUMBERS:		PIN-1	PIN-2	PIN-3	PIN-4	PIN-5	PIN-6	PIN-7	PIN-8	
COLOR IN CDI CABLE G19-0034:		BROWN	RED	ORANGE	YELLOW	GREEN	BLUE	VIOLET	BLACK	
STRAPPED GAGE DATA OUTPUT TYPE:	GAGE DISPLAY (MOVE/2ND , ON /CLR , & MOVE/2ND):	PIN FUNCTION:								NOTES:
ODI DATA OUTPUT	Odi	ODI FORMAT DATA STROBE	BCD-A	BCD-B	BCD-C	BCD-D	REMOTE HOLD	REMOTE CLR OR POWER	SIGNAL GROUND	1. CONTINOUS OUTPUT WITH NO HANDSHAKES. 2. 8 4-BIT NIBBLES ARE OUTPUT PER GAGE READING, FIRST NIBBLE IS SYNC NIBBLE AND IS DETECTABLE BY IT S NON-BCD NATURE. 3. ONE STROBE PULSE FOR EACH NIBBLE.
RS232 DATA OUTPUT WITH OR WITHOUT PARITY	rS232	STRAP STROBE (STRAP TO PIN-5 FOR RS232, TO PIN 4 TO ADD PARITY)	TXD FROM GAGE	/DATA REQ. TO GAGE	TO ADD PARITY STRAP TO PIN-1	STRAP TO PIN 1	REMOTE HOLD	REMOTE CLR OR POWER	SIGNAL GROUND	
MITUTOYO DATA OUTPUT	SEr	STRAP STROBE (STRAP TO PIN-4)	DATA FROM GAGE	CLOCK FROM GAGE	STRAP TO PIN-1	/REQ. TO GAGE	REMOTE HOLD	REMOTE CLR OR POWER	SIGNAL GROUND	
ODI REMOTE INDICATOR OR RAW QUAD-RATURE WAVE OUTPUT	bp	STRAP STROBE (STRAP TO PIN 3)		STRAP TO PIN 1	QUAD-RATURE WAVE A	QUAD-RATURE WAVE B	REMOTE HOLD	REMOTE CLR OR POWER	SIGNAL GROUND	

TROUBLESHOOTING PROBLEMS AND SOLUTIONS

TROUBLESHOOTING: Before calling CDI with an interface problem please review the following troubleshooting cases:

PROBLEM 1: My data interface from the gage does not work properly. When I check the data I/O format of the gage using the key sequence "MOVE/2ND", "ON/CLR", and "MOVE/2ND" I do not see the data output format that I expect indicated on the display.

SOLUTION 1: Make sure the data cable is plugged into the gage before the gage is turned on; the gage self configures itself by reading jumper straps in the interface cable during the first moments after power up. If the gage still reads the wrong interface configuration, disconnect the data receiving device that is connected to the non-gage side of the interface cable. If the gage still reads the wrong interface configuration, the cable is defective, or set for the wrong interface configuration. If you are using a CDI supplied cable verify that the cable is the proper one for the data output configuration you desire (see the "CDI Accessory Product Accessory Catalog" section at the end of this document for the part numbers of the available CDI cable assemblies).

If the gage interface configuration is displayed correctly, with the non-gage side of the cable unattached, there is a problem with the receiving device that was connected to the data cable. It is likely that the receiving device is interfering with the data I/O cable strap reading at gage power-up. To correct problems with data reading devices connected to the gage, please read the section titled "GAGE INTERFACE TECHNICAL DETAILS", also see "PROBLEM 2" below.

PROBLEM 2: When I check the data I/O format of the gage, using the key sequence "MOVE/2ND", "ON/CLR", and "MOVE/2ND", I only see the data output format that I expect indicated on the display if my data reading device was powered up before I powered up the gage.

SOLUTION 2: The powered down data reading device is loading down one or more of the gage's data lines, thus causing the gage to erroneously read the connector cable strapping. Either have the reading device powered up before the gage, or make sure that any of the gage lines pin 2 to 5, that are connected to the reading device, include a series diode and pull-up resistor as shown in the section titled "GAGE INTERFACE TECHNICAL DETAILS".

PROBLEM 3: I periodically have my gage display go to an "ERROR" condition for no apparent reason.

SOLUTION 3: There is most likely a noise condition causing the gage to see erroneous pulses; rather than count these extra pulses, the gage electronics are smart enough to detect them and invalidate the display reading. Certain out of alignment conditions can also cause an "ERROR" display; for example a gage that has been dropped may no longer count properly without factory service. To isolate the source of an "ERROR" display follow the following steps:

- a. Disconnect the gage from all I/O and power supply cabling, run gage on fresh batteries, move spindle at moderate speed while hand holding gage; if gage counts up and down with no "ERROR" display proceed to step "b." below. If gage displays "ERROR", return to gage to CDI for service.

TROUBLESHOOTING PROBLEMS AND SOLUTIONS (con't)

b. Place gage in measurement situation where "ERROR" display occurred, but do not connect any cabling to the gage (this step may just involve mounting the gage in a test fixture, etc.), let any nearby equipment run as it normally would during gage use, move the spindle and observe display, plug in AC adapter and repeat. If gage "ERROR"s without cabling attached there is noise entering the gage through the air, or test stand. If gage "ERROR"s with the AC adapter attached there is noise entering through the AC line.

The "LOGIC" series gages are electrically hardened and tested to operate in extremely electrically noisy locations, and with AC sources that are electrically noisy. In the unlikely situation that the local electrical environment is causing an "ERROR" condition, try moving the physical position of the gage and cables; even a few inches may make a difference, also try a different receptacle position if an AC adapter is being used.

**CDI DATA OUTPUT CABLE
(ORDER CDI # G13-0034 CABLE ASSEMBLY)**

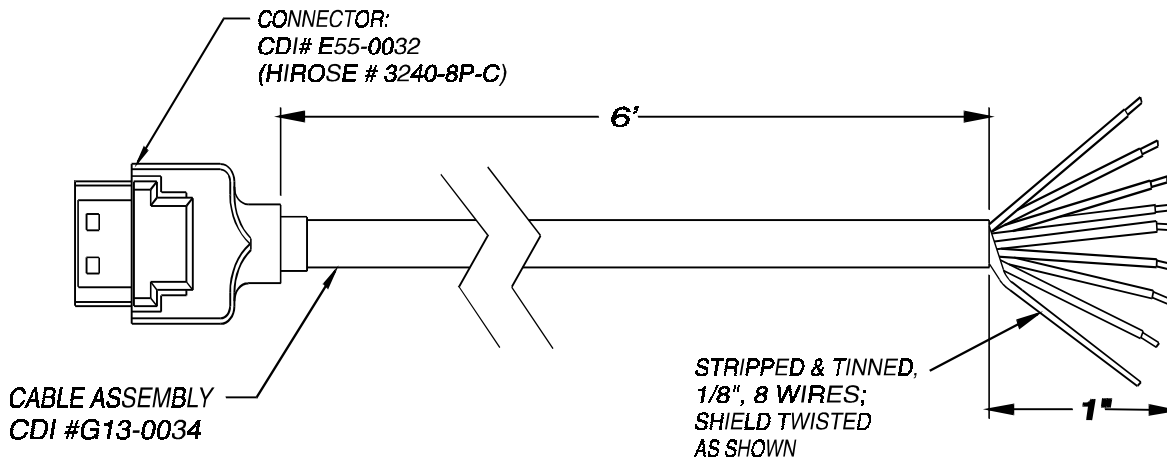

NOTES:

1. CABLE CONNECTIONS:

SHIELD TO INTERNAL METAL HOUSING (STRAIN RELIEF CRIMP); OTHER WIRES = 1 = BROWN, 2 = RED, 3 = ORANGE, 4 = YELLOW, 5 = GREEN, 6 = BLUE, 7 = VIOLET, 8 = BLACK

2. THIS INFORMATION IS FURNISHED TO 3RD PARTIES FOR REFERENCE ONLY

3. IF PIN 7 (VIOLET WIRE) IS USED FOR EXTERNAL INPUT OF +VCC, THE VOLTAGE SOURCE MUST BE REGULATED BETWEEN 4.9-5.5 VDC, AND IS TO BE FREE OF RFI/EMI, NOISE, HUM, RIPPLE, ETC.

PIN#	FUNCTION:	COLOR
1	STROBE	BROWN
2	BCD A	RED
3	BCD B	ORANGE
4	BCD C	YELLOW
5	BCD D	GREEN
6	OPT. HLD/ERR	BLUE
7	OPT +/ON-GLR	VIOLET
8	SIG GND	BLACK
SHLD	CASE GND	BARE/TIN

RS232 DATA OUTPUT CABLES
CDI # G03-0018 (PC)
CDI # G03-0021 (CDI OR UTRONICS PRINTER)
CDI # G03-0034 (SQC/SPC PRINTER)

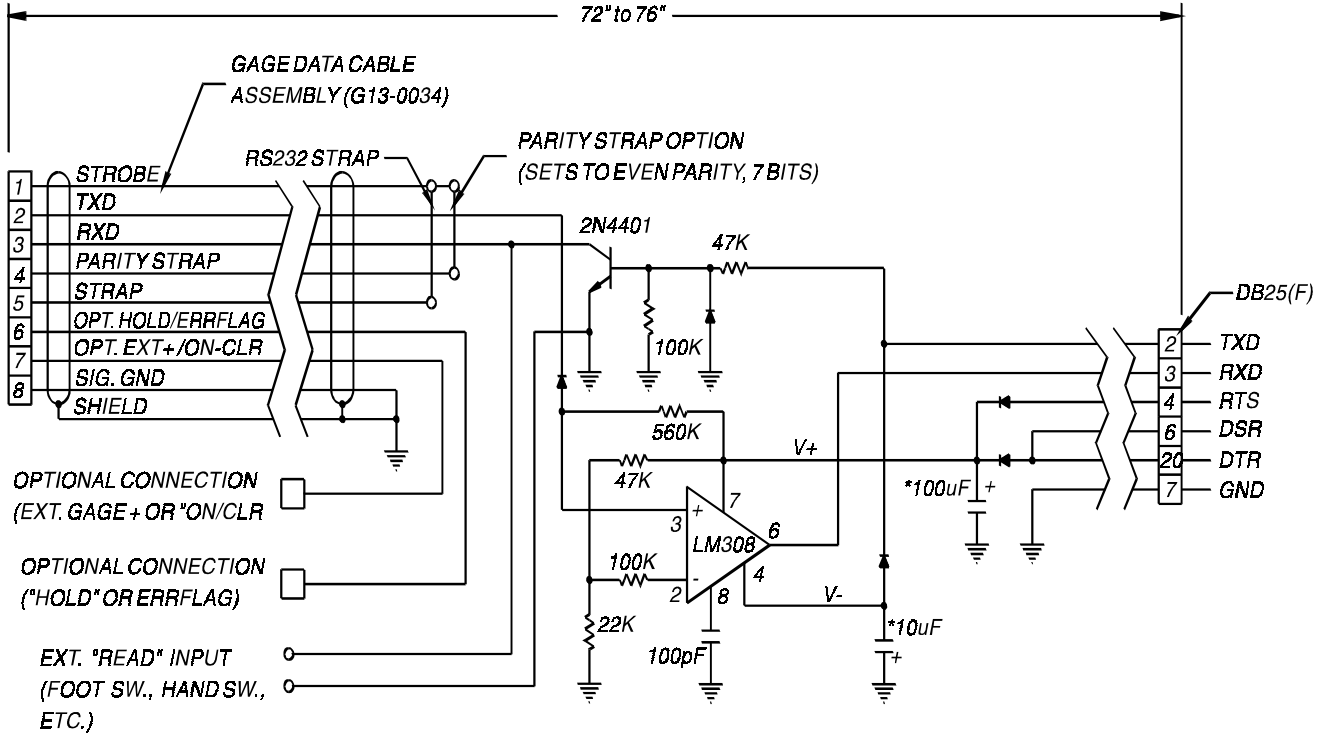

NOTES:

1. CIRCUITRY SHOWN IS BUILT INTO DB25(F) CONNECTOR E55-0048 ON P.C. BOARD E56-0034
2. CONNECTIONS AT DB25 CONNECTOR ARE SHOWN FOR "IBM COMPATIBLE PC."
3. DIODES ARE TYPE 1N914/1N4148 OR EQUIV. RESISTORS ARE 1/4W OR 1/8W, 10%; CAPACITORS ARE 16V MINIMUM, 20%, EXCEPT THOSE MARKED * ARE "GMV"
4. THIS INFORMATION IS FURNISHED TO 3RD PARTIES FOR REFERENCE ONLY.

CDI ACCESSORY PRODUCT CATALOG

<u>DESCRIPTION:</u>	<u>CDI STOCK NUMBER:</u>
CDI DATA OUTPUT CABLE	#G13-0034
RS232 DATA OUTPUT CABLES	#G03-0018 (PC)
	#G03 -0021 (CDI OR UTRONICS PRINTER)
	#G03-0034 (SQC/SPC PRINTER)
MITUTOYU DATA OUTPUT CABLE	#G03-0019
REMOTE DISPLAY TO STANDARD GAGE CABLE	#G03-0022
A.C. ADAPTER, 110 VOLT	#G11-0012
A.C. ADAPTER, 220 VOLT	#G11-0014

REVISIONS:

1. 6/18/98 REVISED PARAGRAPH 3, PAGE 11; CLARIFIED REMOTE “ON/CLR” FUNCTION.