

# BCS Series

## Electronic Crane Scales

CE



- **Superb Quality**– Aluminium-casting case, high firm hook and shackle. GB/T11883-2002 and European CE directives
- **Strong Reliability**– Cutting edge technology, quality integrated circuit for high performance and long time stability
- **Three Popular Capacities**–  
1000 kg / 2000 lb  
3000 kg / 6000 lb  
5000 kg / 10,000 lb
- **Visible LED Display**– Adjustable brightness for any environment
- **Dual Power**– Internal rechargeable battery or AC power
- **Remote Control**– Offers increased safety and convenience
- **Auto-Off Function**– Can be set from 0 to 60 minutes

# BCS Series Electronic Crane Scales

## Features

Brecknell crane scales are versatile, economic solutions for overhead material handling and weighing applications.

**Remote Control:** Puts all scale functions at your fingertips

**Elongated Upper Shackle:** Accommodates thick hooks

**Swivel Hook with Latch:** Makes load connection easy and secure

**Bright LED Display:** Has three adjustable brightness levels for any environment

**Dual Units of Measure:** Displays kg or lb

**Accumulator Function:** Calculates total weight

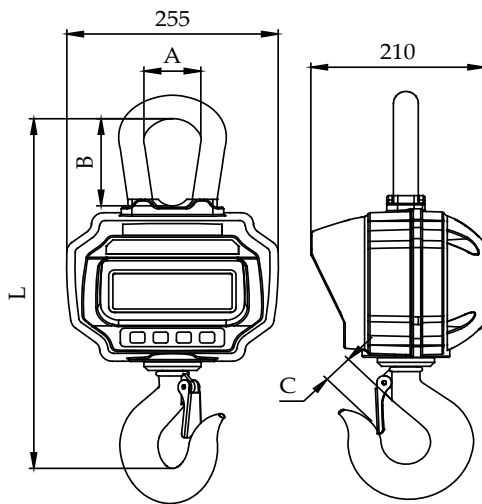

Model	A	B	C	L
BCS-1000	68 mm / 2.67"	112 mm / 4.4"	40 mm / 1.5"	420 mm / 16.5"
BCS-3000	68 mm / 2.67"	112 mm / 4.4"	40 mm / 1.5"	420 mm / 16.5"
BCS-5000	68 mm / 2.67"	112 mm / 4.4"	45 mm / 1.7"	450 mm / 17.7"

### Part Number:

816965006618: 2000 lb / 1000 kg  
 816965006625: 6000 lb / 3000 kg  
 816965006632: 10,000 lb / 5000 kg

## Specifications

**Capacities:** 1000 kg x 0.5 kg / 2000 lb x 1 lb  
 3000 kg x 1 kg / 6000 lb x 2 lb  
 5000 kg x 2 kg / 10,000 lb x 5 lb

**Accuracy:** +/- 0.1% of full scale

**Factory Calibration:** 39° latitude optimized

**Dimension:** 255 mm (L) x 210 mm (W) x 440 mm (D)  
 10" L x 8" W x 17" H

### Power:

Crane: 7.2VDC power adapter, 1000mA with central positive and 6V/4.0Ah lead acid rechargeable battery (both included)

Remote Control: Two AA batteries (included)

### Options:

AWT05-508543 - Power adapter

AWT05-503633: Remote control

**Typical Battery Life:** Depending on LED brightness and idle mode setting, battery works from 60 hrs to 200 hrs

**Charging Time:** Approximately 12 hrs; red LED charging, green finished

**Display:** 35 mm / 1.4" ultra-bright LED

**Remote Functions:** Zero, tare, hold, acc, del F1, F2, off, 2nd

**Remote Distance:** Maximum 10 m / 32'

**Tare Range:** 100% F.S.

**Zero Range:** 4% F.S.

**Stable Time:** ≤10 sec

**Overload:** 100% F.S. + 9 divisions

**Overload Indication:** Internal counter at +9 divisions F.S.

**Ultimate Safety Factor:** 400% F.S.

**Safety Load:** 150% F.S. of capacity

**Operating Temperature:** -10° C to 40° C / 14° F to 104° F

**Operating Humidity:** 20° C ≤90%

**Shipping Weight:** 12.65 kg / 27.88 lb

### Packaging Dimension:

600 mm (L) x 270 mm (W) x 310 mm (H)  
 23" L x 10" W x 12" H

**Accuracy Class:** GB/T 11883-2002 Class III

**Agency Approvals:** CE, EC Machinery Directive