

BOLT user manual

v1.00
Part No:
SU6674

Index

Introduction	1
Fitting the batteries	2
To Clamp a BOLT	3-5
Wire Rope Diameters	6
Notes	7

Introduction

'BOLT' is used to measure the tension on a wire rope by clamping the device on to a wire rope using the two bolts.

Unless specified while ordering, the BOLTs are calibrated as a standard with 32mm wire rope to 10te WLL. BOLT can only be used on specific wire rope diameter with which it is calibrated for; this info will be provided on the calibration certificate.

Every BOLT is supplied with a USB dongle for the user to perform an onsite calibration for better accuracy. For detailed calibration procedure contact SP distributor.

It is recommended to perform an onsite calibration to achieve an accuracy level of 2-3% FS or if the wire rope diameter is different to the one calibrated from factory.

NOTE: It is the responsibility of the end user to ensure the BOLT is calibrated to the correct wire rope diameter to achieve the required accuracy.

Fitting the batteries

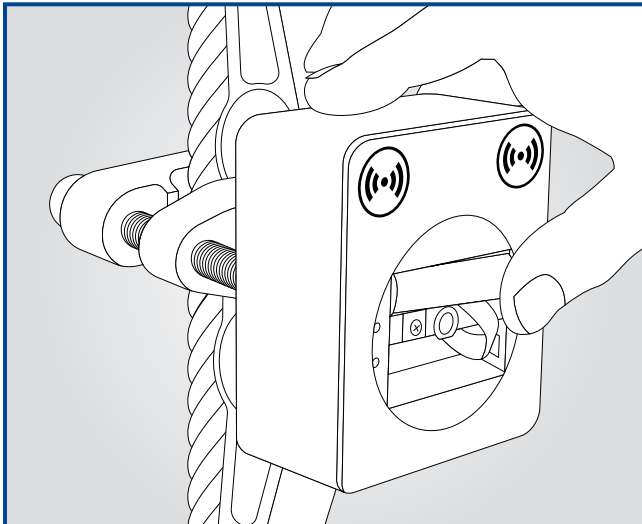
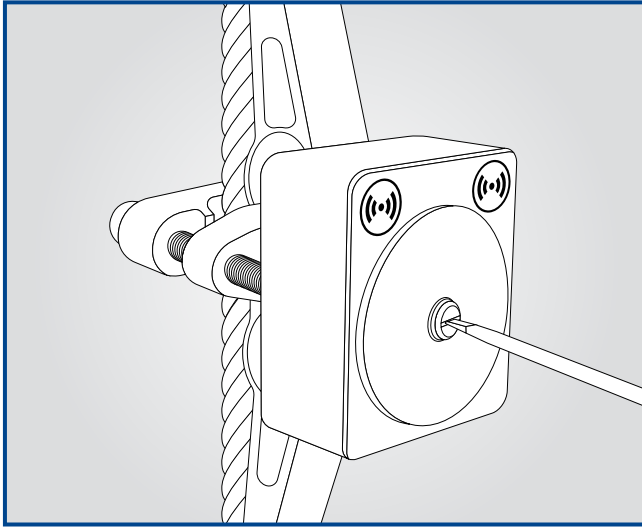

IN A SAFE AREA ONLY, remove the side cover of the BOLT using a flat blade screwdriver.
Fit batteries and refit cover.

The BOLT may be connected to the Straightpoint SW-HHP ATEX handheld, in hazardous areas, or to our range of load monitoring software that is not covered in this manual.

Warning: Make sure batteries are fitted correctly and that the polarity is correct.

To Clamp a BOLT

BOLT can be used on a range of wire rope of diameters from 16-32mm.

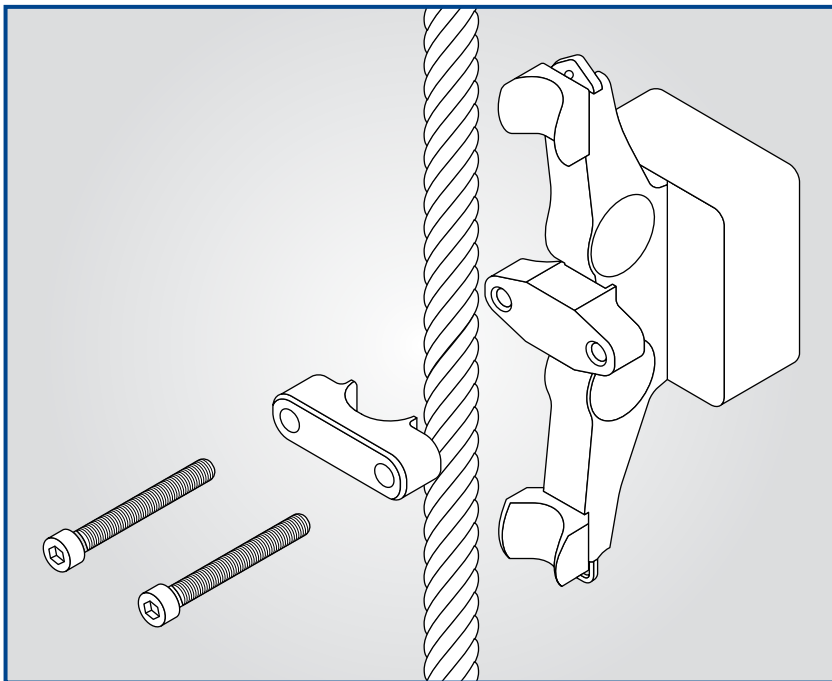

Remove the two M10 bolts of the device place the device under the rope being measured attach the top clamp and tighten the bolts.

To Clamp a BOLT

v1.00
Part No:
SU6674

03

To Clamp a BOLT (contd.)

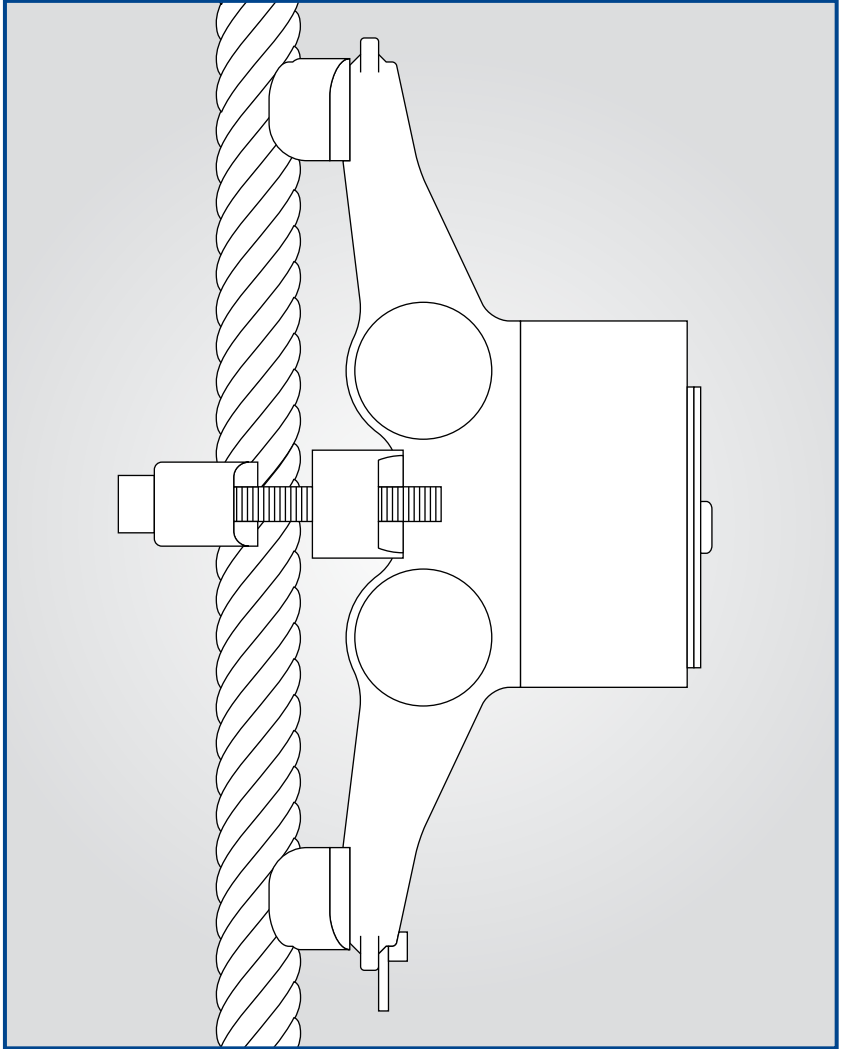

Make sure the bolts are torqued up equally, the torque rating is provided on the calibration certificate.

To Clamp a BOLT (contd.)

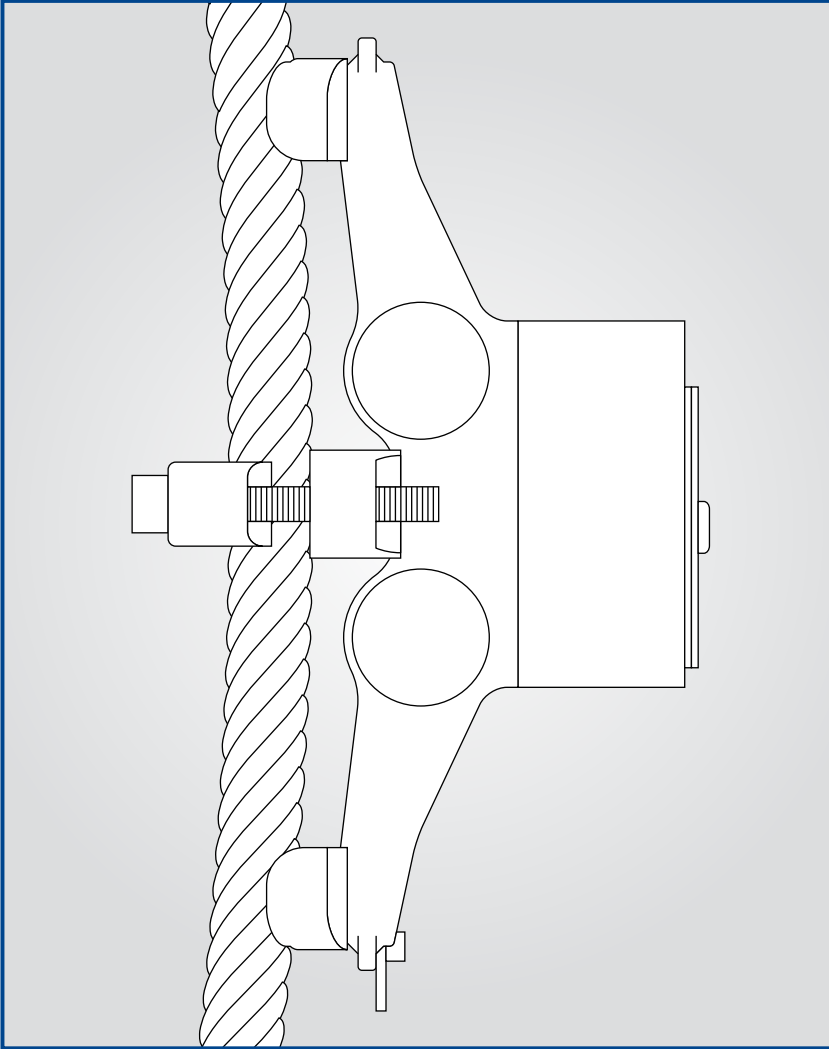

Note: It is important that the two bolts are tightened equally, if not it could show incorrect readings

To Clamp a BOLT

v1.00
Part No:
SU6674

05



Wire Rope Diameters

v1.00
Part No:
SU6674

06

Wire Rope Diameters

Wire rope diameter (mm)	Torque setting (Nm)
32	30
26	20
16	10

In case using a wire rope diameter different to the calibrated one, torque it until the rope is in contact with BOLT body and use a torque wrench to measure the torque value.

After calibration make sure the BOLT is tightened to the same torque value.

It is recommended to perform periodic checks on the BOLT including visual inspection and making sure the bolts are torqued correctly.

NOTE: Care to be taken not to drop the sheave or bolts while working at a height