

# BOLT

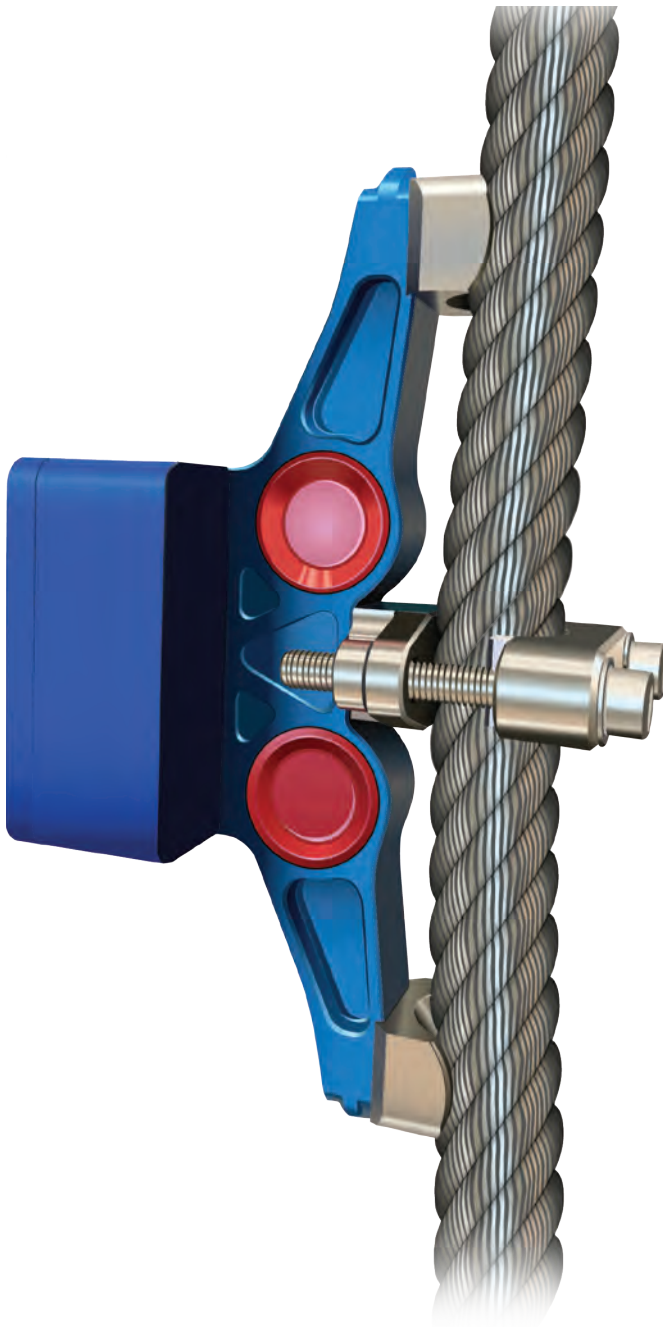

The Crosby Straightpoint BOLT, Bolt On Line Tensiometer, is a lightweight wire rope tension meter or shunt tension meter for fast and accurate measurement of tensions up to 20,000lb or 10,000 kg and up to 1.25" or 32mm diameter.

The BOLT is specifically designed to be mounted in a permanent position on wire rope or cable to monitor the tension.

In combination with a Crosby BaseStation, loads can be monitored remotely. The BaseStation transmits data to a cloud software solution, LoadConnect. This software solution has a dashboard that facilitates a user to see live loads, monitor errors, access historical readings, and view analytics and asset management. Added to this, you have the option of SMS alerts sent directly to your mobile device.

This combination will provide reduced site visits, improve decision making and safely monitor line tensions from any distance from anywhere in the world.

Manufactured, using an integral, high accuracy, wireless module the BOLT can also be paired with and transmit load data to a Crosby SP Handheld plus (SW-HHP), which will enable you to read up to four load cells simultaneously.

Constructed from aerospace-grade aluminium the BOLT digital tensiometer is lightweight and easy to handle and operates on wires that are already under tension. Once installed it enables the operator to quickly check tension on cables or wire ropes set at any angle.

Multiple drop tested from 3 metres or 10 feet.

Supplied in a purpose-made robust packaging, and inclusive of an SW-D dongle, to make on the spot calibrations to achieve greater accuracy of 3%; standard factory accuracy is 5%.

## Optional readouts:

- SW-HHP long-range 2.4GHz version providing an industry-leading wireless range of 1000m or 3280ft
- INSIGHT Software multi channel display and datalogging, connect 126 BOLT's, wireless range of 700m or 2300ft
- LoadConnect Software connect up to 16 load cells per BaseStation no max range, see live data from any distance

## Features and benefits:

- Proprietary 2.4 GHz Wireless
- Leading Wireless Range of 1000m/3280ft when connected to SW-HHP
- Unlimited range when connected to BaseStation
- Unrivalled Battery Life of 1200hrs
- Internal Antennae
- Remote On-Off from handheld display or software

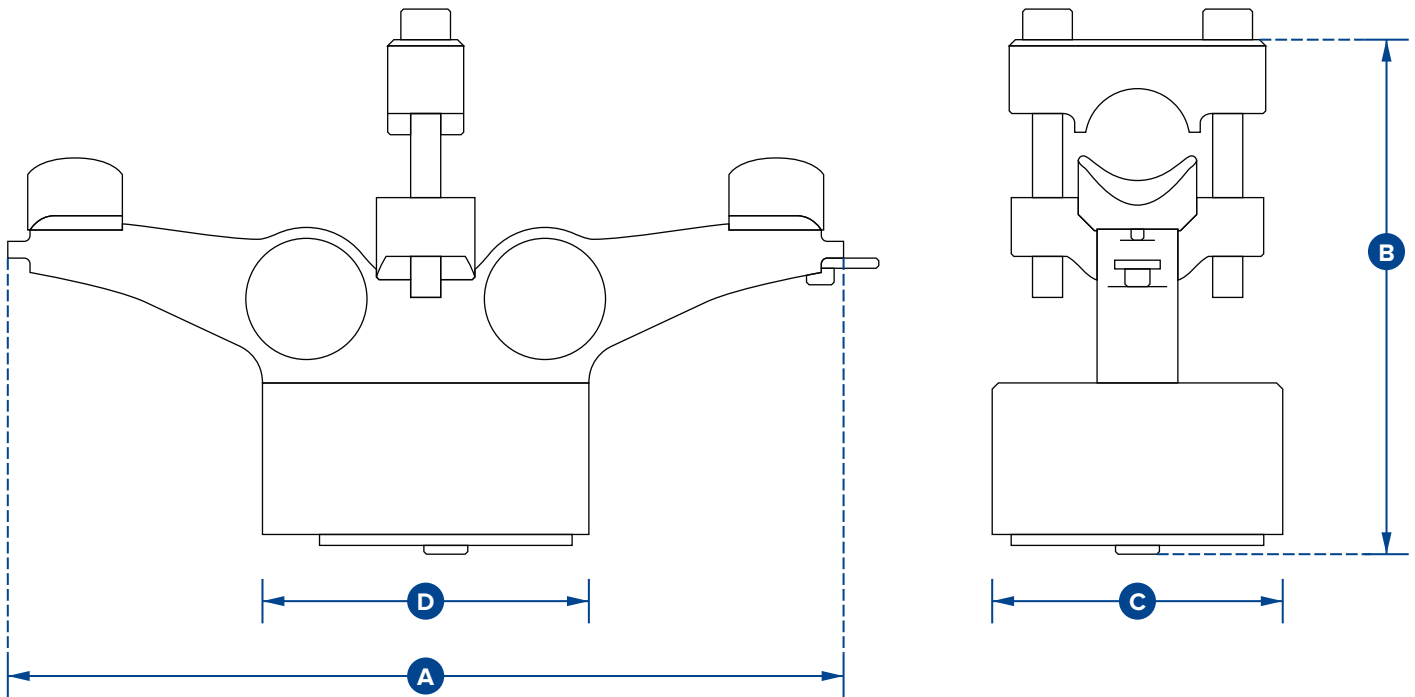

## Applications:

- Guy wire maintenance and monitoring on cell towers, bridges, flare stacks, antennas and masts.
- Guy wire Tower Plumb and Tension
- EHS guy wire, Turnbuckle tensioner.
- Wire rope installations, comparing, equalising and measuring
- Architectural wire rope installations
- Median cable barrier tensioning
- Utility cable overhead line monitoring
- Governor & compensating wire rope maintenance
- Zip lines & assault course testing
- Fall arrest systems
- Metro, tram and rail transit electric wires & catenary testing
- Ski lifts
- Wire rope tie downs on vessels (using Tirfor)
- Testing tension of ship mast wire ropes.
- Tensioned trellis systems
- Measuring Line Sag

Part Numbers	
SP	BOLT10T
Crosby	1739573
Maximum Load	10te 22,000lb
Resolution	0.01te 20lb
Units	kg, lb, tonne & kN kg, lb, tonne & kN
Min Wire Rope	Ø 16mm Ø 0.63"
Weight	2.1kg 4.6lb
Battery Type	4 x AA cell batteries
Battery Life	1200 hours
Operating Temp	-10°C to +50°C or 14°F to 122°F
Protection	IP67 or NEMA6
Accuracy	Typically 3-5%
Communication	2.4GHz
Dimension A	259 10.20"
Dimension B	159.10 6.26"
Dimension C	89 3.50"
Dimension D	102 4.01"