

## Advancing with Technology **ElektroPhysik**

### Road layer thickness measurement



### StratoTest 4100

**Thickness gauge for asphalt, slag  
and concrete materials**

- Non-destructive measurement
- Immediate display of readings
- Thickness range up to 40 cm/15"
- Measurements repeatable at the same spot
- Complete print-out of all site measurements

**New: Special probe for up to 80 cm/31"  
thickness range**

## StratoTest 4100 the precise electronic measuring gauge

### On-site testing of pavement thickness

Designed for on-site testing of pavement thickness, this most accurate electronic gauge provides immediate thickness readings of road layers during construction work. As a result, road layers can be paved more accurately and economically avoiding increased factor of safety for pavement thickness. At the same time, the risk of invoice deductions can be prevented when it comes to cost settlement.

### For road inspection

The easy to operate StratoTest provides quick and accurate readings without the need of extended set-up

times. With real-time test reports being immediately at hand, the StratoTest proved to be the ideal gauge for road inspection. Readings are provided in correlation with their relevant measuring spots and stations.

### For road construction authorities

During pavement works, reflector foils are installed under the road layers at pre-selected measuring spots for later inspection through the road construction authorities. Mounted on a foldable dolly, the gauge fits into any car.

### Science and research

High-precision readings through StratoTest represent the base for



statistical evaluation of material thickness variations caused by uneven pavements, wearing, deformation or other important factors impairing road layer material quality.

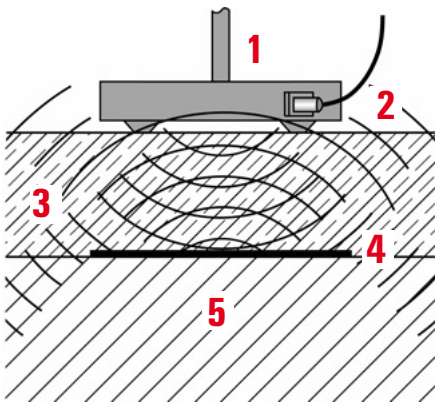

#### Probe and reflector

- 1 Probe
- 2 Electro-magnetic field
- 3 Layer to be measured
- 4 Reflector
- 5 Sub-base

### Application

The core drill method of road surface testing is a destructive, time-consuming, costly and inaccurate procedure. The StratoTest has none of these drawbacks, combining completely non-destructive measurement with accurate and repeatable test results displayed within seconds. The newly developed gauge is based on 20 years experience particularly for experts in road construction. As with former models the new gauge measures the thickness of all materials used in road construction.

Initially developed for measuring bituminous wearing courses, the StratoTest nowadays is mainly used for road inspection and cost settlement according to the German standard TPD StB 89. Due to its versatility, it can also be used for wall thickness measurement or thickness measurement of unreinforced concrete linings.

Measurement with StratoTest is unaffected by humidity or temperature of the layer material. Furthermore, even strong variations in the magnetic or electrical properties of the layer material or variations in the ambient temperature do not impair the measuring results.

### Measuring principle

Prior to road paving, measuring reflectors are installed on the sub-base at pre-selected spots. As reflectors, self-adhesive aluminium foils or sheets (generally 1 m x 0.3 m) are placed in direction of traffic. The reflectors serve as a reference for thickness measurement after the road has been paved over the measuring spot.

The new StratoTest not only allows the measurement over standard size reflectors but also over all typical reflector sizes, even on large steel parts (surfaces on bridges).

The gauge probe takes the form of a disc-shaped coil assembly working on energised high frequency. As the probe approaches the aluminium sheet, the pick-up coil registers the field density, which in turn is directly related to layer thickness. The StratoTest evaluates the results immediately, displaying readings digitally in cm or inch.



**A new searching mode now enables the simple, safe and quick location of the reflectors**

- Acoustically via headphones (audible also during street noise)
- Optically by an analogue indication of the minimum
- Digitally by an indication of the lowest reading

The StratoTest can be used in two modes, in the DIRECT mode and in the SITE mode. The DIRECT mode is to be used for the immediate measurement:

Switch on – search – measure

The single readings and their calculated statistics are memorized and can be transferred immediately or later to the portable data printer MiniPrint or to a PC.

The SITE mode enables the operator to put in code numbers for a clear identification of the readings:

- to the site
- to the kind of layer material to be measured (surfacing, binder course, base course, etc.)
- to the measuring station and
- to the measuring position within the station

The stored data together with the readings and their calculated statistics can be transferred immediately or later to the portable printer MiniPrint or to a PC.

Every stored reading can be found under the relative position number. With the supplied calibration plate the gauge can be checked at any time for accuracy.

## Reflectors

From both a technical and a cost-effective stand-point, we have found the ideal reflector to be a thin, self-adhesive strip of aluminium foil. The natural roughness of the asphalt surface and the pressure exerted by the grader roller result in an excellent bonding of the layers. The binder in the bituminous mixtures ensures additional bonding of layer and reflector foil. Although sharp particles in the sub-base may cause occasional flaws in the foil, this will not impair measurement.

If there is a very coarse sub-base in conjunction with unconsolidated layers (frost blanket gravel), it is preferable to use aluminium plates because of their greater stability.

The reflectors can be delivered as rolls or as cut foil in all typical sizes. They are self-adhesive and therefore can be placed accurately. Even heavy trucks cannot damage the foil. Please ask for more details and prices.



## Technical characteristics

- Non-destructive measurement
- Direct thickness indication in cm or inches
- Measuring range from 0... 40 cm, resolution 0.01–0.4 cm
- Optional probes up to 80 cm
- Repeatable measurements
- Simple and safe location of the reflector: audible signal, with analogue and digital indication
- Quick and reliable accuracy check with calibration plate
- Calibration feature with certified calibration distance pieces
- Adjustment of an OFFSET value. This is automatically added to or subtracted from every reading. The adjusted OFFSET value is indicated with every print-out and with every data transfer
- Large display with operator advice
- DIRECT mode for immediate measurement
- SITE mode with correspondence between readings and site code numbers
- Storage of readings and statistical values for immediate or later print-out
- Data print-out on MiniPrint data printer
- Transfer to a PC in ASCII format
- Foldable dolly to fit in any car
- Weather protection box with Plexiglas cover mounted on dolly for storing gauge and printer. The Plexiglas cover may also be used as a writing pad.
- 10 cm and 80 cm probe with device for convenient handling

## StratoTest 4100

### Technical data

Measuring principle:	eddy current testing		
Measurable layers:	all non-metallic road layer materials		
Reflectors*:	aluminium foils or sheets of different sizes		
Measuring ranges:	0...40 cm (N400ST standard probe); 0...10 cm (N100ST optional probe); 0...80 cm (N800ST optional probe)		
Resolution of standard probe:	0.1 cm from 0...30 cm 0.2 cm from 30...35 cm, 0.4 cm from 35...40 cm		
Tolerance of standard probe:	Reflector	Measuring range/(cm)	Tolerance
		0...30	± (0.1 cm + 2% of reading)
	0.7 m x 0.3 m	30...35	± 2% of reading
	1.0 m x 0.3 m	35...40	± 3% of reading
		0...30	± (0.1 cm + 2% of reading)
	0.6 m x 0.6 m	30...35	± 2% of reading
	1.0 m x 1.0 m steel	35...40	± 2% of reading
Display:	digital on LCD		
Data storage:	DIRECT mode: approx. 500 single readings and statistical values		
	SITE mode: approx. 6,000 single readings incl. statistics;		
	5 site memories available with 300 stations each; 4 measuring spots per station; 5 layer material types per measuring spot		
Power supply:	1 x 9 V alkaline battery		
Battery life:	approx. 20 hours		
Ambient temperature:	Gauge: 0°C...50°C, probe: 0°C...70°C		

\* available at ElektroPhysik

### Delivery schedule

Dolly with weather protection box and soft carrying case including

- StratoTest 4100 gauge incl. alkaline battery
- N400ST probe
- Connecting cable for probe and gauge
- Calibration plate
- Headphones
- Instruction manual

### Optional probes

- N100ST probe, up to 10 cm
- N800ST probe, up to 80 cm

### Recommended accessories

- Portable data printer MiniPrint with built-in storage battery, connecting cable and battery charger

- Foil dispenser for easy and accurate cutting of self-adhesive aluminium reflector foils
- Thickness standards according to TPD StB 89 incl. 6 distance pieces from 10 mm to 220 mm thickness and soft bag for transportation and storage
- 9 Volt storage battery incl. charger

### Other gauges from our range of products

- Coating thickness & Wall thickness gauges
- Porosity detectors
- Gloss measuring gauges
- Hardness & Roughness testers
- On-line systems for continuous thickness measurement of films and sheets
- Continuous pinhole detectors

The following example shows the print-out with MiniPrint in SITE mode:

ElektroPhysik StratoTest		
16-Jan-01 15:30	<i>date and time of print-out</i>	
Probe N400ST	<i>type of probe in use</i>	
SITE 1234	<i>no. of site</i>	
Coating 2	<i>kind of layer 2 = binder</i>	
No. of pos. 3	<i>3 measuring positions: left, middle, right</i>	
OFFSET 0.0 cm	<i>constant value (here 0.0 cm) add or subtract</i>	
STAT POS COAT	<i>station<sup>1</sup> measuring position<sup>2</sup> coating thickness<sup>3</sup></i>	
0.000 1 8.1 cm	<i><sup>1</sup> max. 300 stations/site</i>	
0.000 2 8.0 cm	<i><sup>2</sup> max. 4 positions/station</i>	
0.000 3 8.2 cm		
0.050 1 8.1 cm		
0.050 2 7.9 cm		
0.050 3 7.9 cm	<i><sup>3</sup> relative readings (max. 500 readings/site) (max. 6,000 readings in total)</i>	
0.100 1 8.0 cm		
0.100 2 8.1 cm		
0.100 3 7.9 cm		
8.300 1 8.2 cm		
8.300 2 8.1 cm		
8.300 3 8.2 cm		
STATISTIC		
Number 498		
Mean	8.1 cm	
St. dev.	0.3 cm	
Kvar	3.7%	
Max.	8.6 cm	
Min.	7.6 cm	
<i>statistics from all readings of one site</i>		