

Model:	HPS0
Indentation Body:	U-grooved 3/32"
Depth of Indentation:	0 - 2.5 mm
Test pressure*:	approx. 12.5 N
Meas. spring force:	0.55 - 8.065 N
Display range:	0 -100 Shore hardness graduation marks
Scale diameter:	54 mm
Working face:	18 mm
Weight approx.	300 g net/ 500 g gross
Dimensions:	50 (L) x 50 (W) x 110mm (L)

*Pressure on test material surface when outer ring is in measuring position.

TABLE OF CONTENTS

1.0	Introduction	2
1.1	Unpacking	
1.2	Complete Kit	
2.0	Operating Procedures	3
2.1	Memory Pointer (optional)	
3.0	Verifying Calibration	4
3.1	Textile Durometers	
3.2	Shore Durometers	
4.0	Available Models	6
5.0	Specifications	8
6.0	Warranty	



WARNING

Pressure on the spring-loaded outer ring which exceeds the range of the instrument by more than 100% may cause permanent damage to the measuring spring and must be avoided under any circumstances.

This device must not be operated in explosion hazard areas and must not come into contact with aggressive substances.

1.0 INTRODUCTION

This manual covers the operation of both the Checkline TEXTILE and SHORE Durometers. Textile Durometers are typically used to check the relative "firmness" or "hardness" of textile yarn packages, bobbins, beams, spools, cones, etc. They are calibrated to measure on an empirical scale of 0-100 units. The different models types use different sized ball sensors (2.5, 5 and 10 mm diameter) and are offered in flat-bottomed versions (used on large diameter cylindrical samples) as well as models with concave-shaped bottom surfaces for use on small-diameter cylindrical test samples.

Shore Durometers are typically used to measure the hardness of a wide variety plastics, rubber, elastomers and similar materials. All models have a flat bottom and differ in the shape of the sensing pin as well as the internal spring force that resists deflection of the sensing pin. All models are calibrated using standards that are specified in various Test Procedures issues by ASTM, DIN and JIS Quality organizations worldwide.

1.1 Unpacking

Unpack the HP Durometer carefully and inspect it for any damage. If damage is found, contact Electromatic immediately by telephone at 516-295-4300 or send email to info@checkline.com.



Durometer with protective plastic cap

1.2 Complete Kit

HP Series Durometers are supplied as a complete kit, including:

- Durometer
- Operating manual
- Carrying case.



5.0 SPECIFICATIONS

Model:	HP-2.5, HP-5, HP-10, HP-2.5F, HP -5F, HP-10F
Depth of Indentation:	0 – 2.5 mm
Test pressure*:	approx. 12.5 N
Meas. spring force:	0.55 N – 8.065 N
Working face radius:	56 mm (only HP 2.5, HP 5, HP 10)
Working face diameter:	45 mm Ø (only HP 2.5-F, HP 5-F, HP 10-F)
Display range:	0 –100 hardness graduation marks
Scale diameter:	54 mm
Weight approx.	300 g net/ 500g gross
Dimensions:	50 (L) x 50 (W) x 110mm (L)

Model:	HPSD
Indentation Body:	Tapered pin 30°, 1.25 mm Ø
Depth of Indentation:	0 - 2.5 mm
Test pressure*:	approx. 50 N
Meas. spring force:	0.98 - 44.5 N
Display range:	0 - 100 Shore hardness graduation marks
Scale diameter:	54 mm
Working face diameter:	18 mm
Weight approx.	300 g net/ 500 g gross
Dimensions:	50 (L) x 50 (W) x 110mm (L)

Model:	HPSA
Indentation Body:	Cone 35°, 1.25 mm Ø
Depth of Indentation:	0 – 2.5 mm
Test pressure*:	approx. 12.5 N
Meas. spring force:	0.55 - 8.065 N
Display range:	0 – 100 Shore hardness graduation marks
Scale diameter:	54 mm
Working face diameter:	18 mm
Weight approx.	300 g net/ 500 g gross
Dimensions:	50 (L) x 50 (W) x 110mm (L)

*Pressure on test material surface when outer ring is in measuring position.

4.0 AVAILABLE MODELS

Textile Durometers

Model	Sensor Ball Diameter	Bottom Surface	Typical Applications
HP-2.5	2.5	Ball	Closely wound bobbins of synthetic fibers
HP-5	5	Ball	Loosely wound bobbins of synthetic fibers and closely wound natural fibers, yarns and threads
HP-10	10	Ball	Very loosely wound bobbins of thick yarns, m such as carpet yarns
HP-2.5F	2.5	Flat	Same as Model HP-2.5 with a flat working face for measuring warp beams, or for bobbin diameters with over 400mm
HP-5F	5	Flat	Same as Model HP-5 with a flat working face for measuring warp beams, or for bobbin diameters with over 400mm
HP-10F	10	Flat	Same as Model HP-10 with a flat working face for measuring warp beams, or for bobbin diameters with over 400mm

Shore Durometers

Model	Indentor Descriptions	Typical Applications
HPSA	Truncated Cone 35° Included Angle	Soft rubber, elastomers, natural rubber products, etc.
HPSB	Conical 35° Included Angle	Rubber, elastomers, use when off the high end of the "A" scale
HPSC	Truncated Cone 35° Included Angle	Medium hard rubber or plastics, use when off the low end of the "D" scale
HPSD	Tapered pin 30°	Hard rubber, rigid thermoplastic products
HPSO	U-grooved 3/32 in.	Soft elastomers, textile fabrics
HPDO	Spherical 3/32 in.	Dense textile winding, medium printing rollers

2.0 OPERATING PROCEDURES

1. Place the instrument on the material to be tested. The durometer must be level, and the sensing pin must be perpendicular to the material to be tested.

Any angle other than perpendicular (90°) may cause errors

2. Holding the knurled, spring-loaded outer shell between fingers, press downwards until the lower edge of the shell meets the red line marked on the housing. This ensures that sufficient pressure is applied as specified in the standard. It also ensures that the same amount of pressure is applied from measurement to measurement, and when the durometer is used by different operators.
3. Record reading after approximately 2–3 seconds. Release pressure on the outer shell and remove the durometer from the test material.

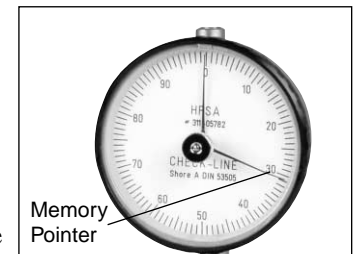
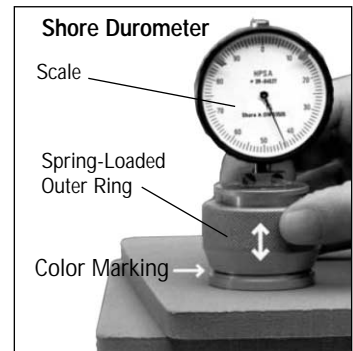
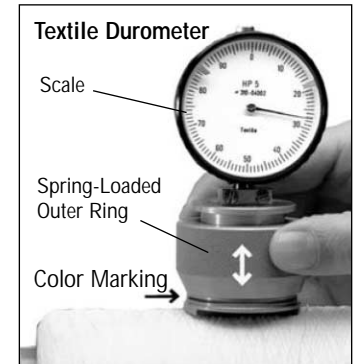

2.1 Memory Pointer (optional)

The Memory Pointer moves with the measurement pointer when a measurement is taken. However, when pressure on the outer shell is released, and the measurement pointer returns to zero, the Memory Pointer remains in position, marking the last measurement.

To return the Memory Pointer to the zero position prior to taking another measurement, rotate the knurled knob on the face of the instrument counter-clockwise until the pointer has been reset. See figure at right.

3.0 VERIFYING CALIBRATION

3.1 Textile Models (HP-2.5, HP-2.5F, HP-5, HP-5F, HP-10, HP-10F)

The Textile Durometers utilize a 0-100 units scale. The units have not formal engineering classification and are not related to a specific Shore value or other known value. These Textile Durometers are designed to obtain objective comparative values that are effective for classifying the end-product quality. Therefore, there are no standards that can be used to compare against and it is for this reason that an NIST-Traceable Calibration Certification can not be performed.

You can however test that the gauge is functional and un-damaged by pressing the flat-bottomed models ("F" models) against a smooth surface (such as glass or marble). When fully pressed down, the dial should perform one complete rotation and go back to "0". When released, it should un-coil, and return to "0" as well. If not, please contact the factory immediately.

On model with a concave base (for measurement on small bobbins or cones), you can perform a similar "full scale" test using the optional Zero Test Block (part number HP-TB).

1. Press the Textile Durometer down on the test plate, which is available as an accessory and can be ordered under item number HP-TB (see Fig. 1). Do not move the spring-loaded outer ring.
2. The scale pointer should make one full turn on the scale, from zero to zero, when you press down on the instrument. If it does not, contact Electromatic for assistance.

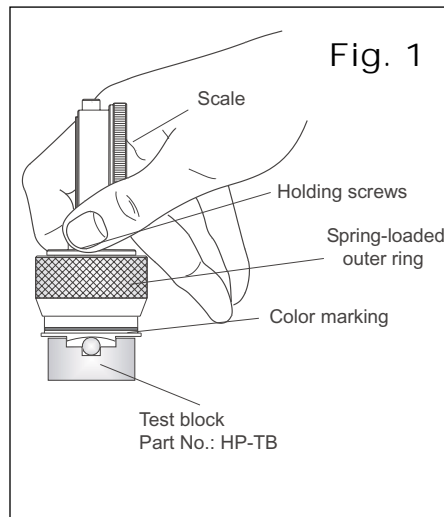

NOTE: Do not loosen the holding screws of the movement under any circumstances. Loosening these screws may alter the calibration of the instrument.

3.2 Shore Models (HPSA, HPSB, HPSB, HPSD, HPSO, HPDO)

The Shore Durometers model are calibrated against industry standards as specified in ASTM, DIN and JIS Test Procedures. Calibrated Test Samples CAN NOT BE USED for verification of the calibration, as these test samples are subject to change due to temperature, sunlight and other ambient conditions. Certification of the calibration is normally done at test facilities that can independent test the internal spring forces of the Durometer and check the travel/reading accuracy of the dial indicator.

Contact factory for the optional NIST-Traceable Calibration Certifications.

1. Press the Shore Durometer down on a glass plate (see Fig. 2). Do not move the spring-loaded outer ring.
2. The scale pointer should make one full turn on the scale, from zero to zero, when you press down on the instrument. If it does not, contact Electromatic for assistance.

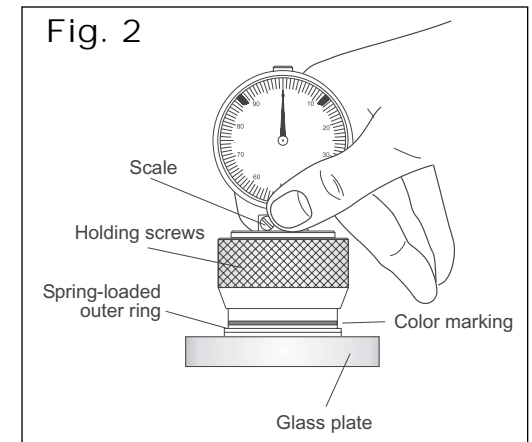

NOTE: Do not loosen the holding screws of the movement under any circumstances. Loosening these screws may alter the calibration of the instrument.

6.0 WARRANTY

ELECTROMATIC Equipment Co., Inc. (ELECTROMATIC) warrants to the original purchaser that this product is of merchantable quality and confirms in kind and quality with the descriptions and specifications thereof. Product failure or malfunction arising out of any defect in workmanship or material in the product existing at the time of delivery thereof which manifests itself within one year from the sale of such product, shall be remedied by repair or replacement of such product, at ELECTROMATIC's option, except where unauthorized repair, disassembly, tampering, abuse or misapplication has taken place, as determined by ELECTROMATIC. All returns for warranty or non-warranty repairs and/or replacement must be authorized by ELECTROMATIC, in advance, with all repacking and shipping expenses to the address below to be borne by the purchaser.

THE FOREGOING WARRANTY IS IN LIEU OF ALL OTHER WARRANTIES, EXPRESSED OR IMPLIED, INCLUDING BUT NOT LIMITED TO, THE WARRANTY OF MERCHANTABILITY AND FITNESS FOR ANY PARTICULAR PURPOSE OR APPLICATION. ELECTROMATIC SHALL NOT BE RESPONSIBLE NOR LIABLE FOR ANY CONSEQUENTIAL DAMAGE, OF ANY KIND OR NATURE, RESULTING FROM THE USE OF SUPPLIED EQUIPMENT, WHETHER SUCH DAMAGE OCCURS OR IS DISCOVERED BEFORE, UPON OR AFTER REPLACEMENT OR REPAIR, AND WHETHER OR NOT SUCH DAMAGE IS CAUSED BY MANUFACTURER'S OR SUPPLIER'S NEGLIGENCE WITHIN ONE YEAR FROM INVOICE DATE.

Some State jurisdictions or States do not allow the exclusion or limitation of incidental or consequential damages, so the above limitation may not apply to you. The duration of any implied warranty, including, without limitation, fitness for any particular purpose and merchantability with respect to this product, is limited to the duration of the foregoing warranty. Some states do not allow limitations on how long an implied warranty lasts but, notwithstanding, this warranty, in the absence of such limitations, shall extend for one year from the date of invoice.

ELECTROMATIC Equipment Co., Inc.
600 Oakland Ave. Cedarhurst, NY 11516—USA
Tel: 1-800-645-4330/ Tel: 516-295-4300/ Fax: 516-295-4399

Every precaution has been taken in the preparation of this manual. Electromatic Equipment Co., Inc., assumes no responsibility for errors or omissions. Neither is any liability assumed for damages resulting from the use of information contained herein. Any brand or product names mentioned herein are used for identification purposes only, and are trademarks or registered trademarks of their respective holders

HP SERIES TEXTILE DUROMETERS AND SHORE DUROMETERS



Textile Models

**HP-2.5, HP-2.5F, HP-5,
HP-5F, HP-10, HP-10F**

Shore Models

**HPSA, HPSB, HPSC,
HPSD, HPSO, HPDO**

