





Albuquerque Industrial  
69-10 108th Street # 2-O  
Forest Hills, NY 11375 U.S.A.

www.abqindustrial.net  
e-mail: info@abqindustrial.net  
Toll Free: +1 (888) 275-5772  
Tel: +1 (718) 846-6458  
Fax: +1 (718) 846-6459

Revisions

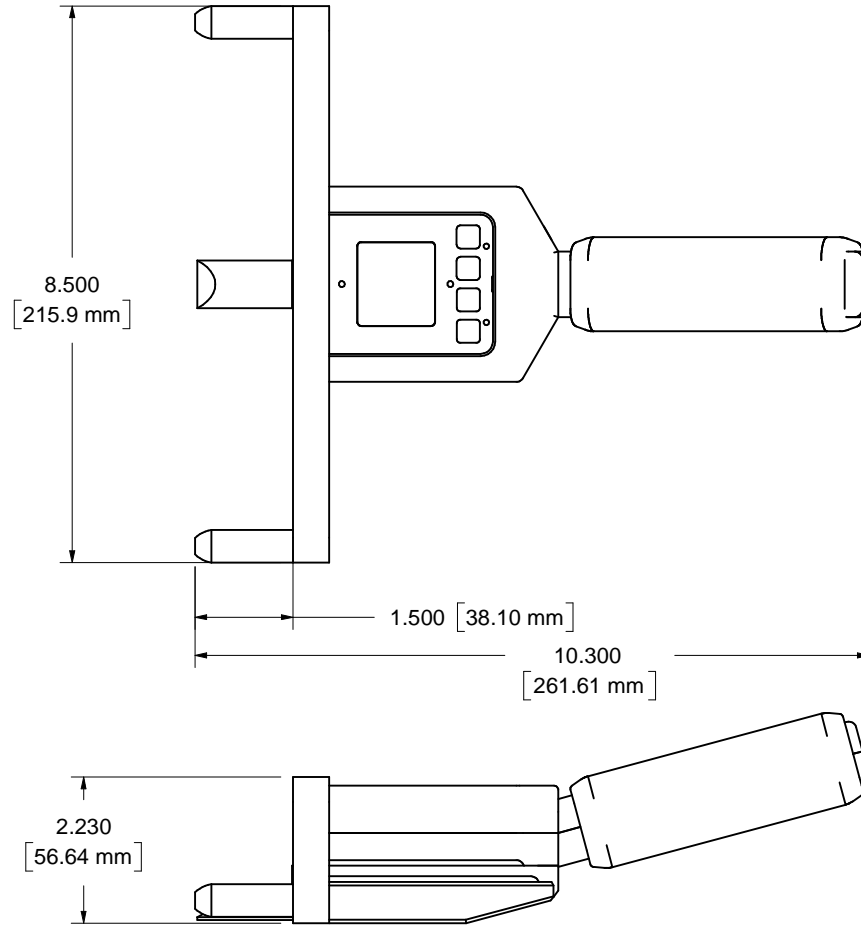
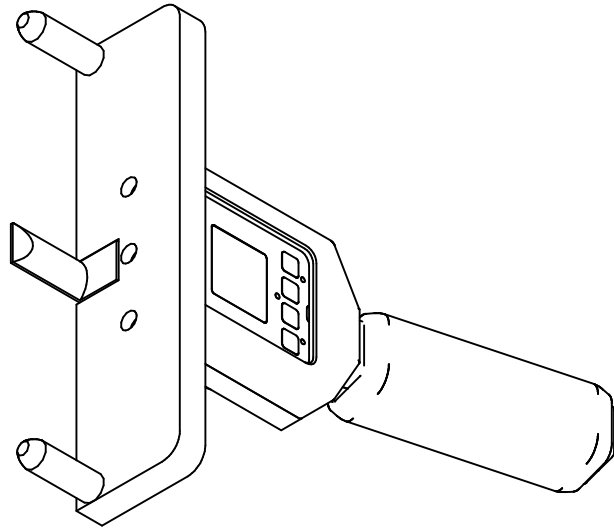
SYM	Description	Date	Approval



Material 6061			Finish CLEAR ANODIZE		Heat Treat		
DIMENSIONAL TOLERANCES UNLESS OTHERWISE SPECIFIED			TITLE		Weight		
FRAC.	DEC.	ANG.	STRAP TENSION METER MAXIMUM TENSION RANGE OF 2,000 LBS		 733 South Bowen Street Longmont, CO 80501		
± 1/64	± .005	± 30°					
Scale 1:3	No. Req'd		Drawn SHS	Date 10-20-08	Size	Drawing Number	Issue
Next Assy			Checked	Date		STX-2000	2
			Approved	Date			