



TT-QC

Torque Tester

- Bidirectional accuracy of $\pm 1\%$ of indicated reading
- Eight selectable engineering units: Oz.in., Lb.in., Lb.ft., Nm, cNm, KgfcM, gfCm, Kgfm
- 3 modes of operation: Track, Peak and 1st Peak
- Rugged Aluminum Housing
- NiMH rechargeable batteries provide 8-10 hours of continuous use
- Includes NIST Calibration Certificate

For testing click, dial, and digital wrenches, plus most power tools including impulse and electric drivers.

Our smallest and lowest cost bench mount torque tester to date, the TT-QC Quick Check is perfect for quick equipment verification right at your workstation. Small and light enough to use anywhere, this unit can still be used alongside any metrology grade tester.



A unique rotating display (optional) and dual bolt pattern allow the tester to be used in both horizontal and vertical configurations, and make switching between the two modes

almost effortless. It is ideal for switching between pistol grip and inline tool checking.

The TT-QC takes just seconds to change test parameters, and works in either one button or automatic modes of operation. Reliability and ease of use are enhanced with features such as Sign Lock, Peak Blanking and Auto Clear.



Compact, easy-to-use bench mount tester provides quick tool verification right at your workstation.

Specifications

Accuracy	±1% of indicated reading (Bidirectional)
Resolution	4 Active Digits
Filtering	Selectable - 125Hz, 250Hz, 500Hz, 1000Hz, 1500Hz and 2000Hz
Operating Temperature	32–122 °F (0–50 °C)
Power	Internal NiMH battery, 9V Charger (included)
Dimensions (WxHxD)	3.125" x 3.75" x 3.25" (78.38 x 95.25 x 83.55mm)
Weight	2.5 lbs (1.13 Kg)

Dimension Drawings

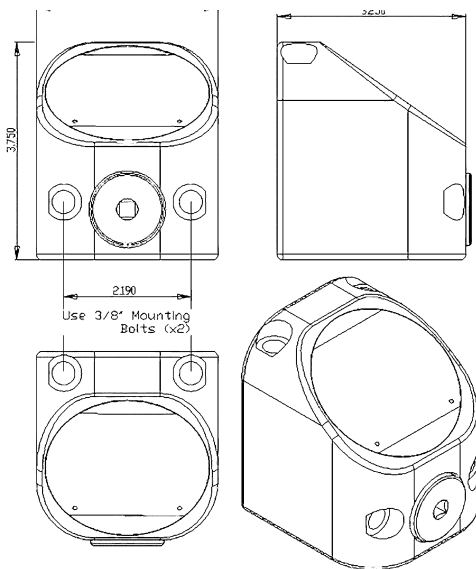

Joint Simulators/Run Down Fixtures

Required for accurate torque measurement for power-driven torque controlled tools (electric, hydraulic or pneumatic).



Torque Ranges

Model	Range Size	Drive Fixture	Run-Down
TT-QC-100z-1/4	10 - 100 oz-in	1/4"	Included
TT-QC-10i-1/4	1.0 - 10 lb-in	1/4"	Included
TT-QC-200z-1/4	20 - 200 oz-in	1/4"	Included
TT-QC-25i-1/4	2.5 - 25 lb-in	1/4"	Included
TT-QC-50i-1/4	5.0 - 50 lb-in	1/4"	Included
TT-QC-100i-1/4	10 - 100 lb-in	1/4"	Included
TT-QC-150i-1/4	15 - 150 lb-in	1/4"	Included
TT-QC-250i-3/8	25 - 250 lb-in	3/8"	Included
TT-QC-500i-3/8	50 - 500 lb-in	3/8"	Included
TT-QC-750i-3/8	75 - 750 lb-in	3/8"	Included
TT-QC-1000i-3/8	100 - 1000 lb-in	3/8"	Included
TT-QC-100f-1/2	10 - 100 lb-ft	1/2"	Optional
TT-QC-150f-1/2	15 - 150 lb-ft	1/2"	Optional
TT-QC-250f-1/2	25 - 250 lb-ft	1/2"	Optional

TT-3000 Torque Tester

The TT-3000 Series Torque Testers are designed specifically for the needs of today's production facilities.

These powerful and versatile systems accommodate most testing requirements at an outstanding cost benefit.



MTM Multi-Range Torque Tester

The MTM Series of torque transducers are designed to provide an economical way to measure and calibrate multiple torque tools. MTM models include an integrated display for a fully integrated tester.



MTMMDP-4 shown, two shaft model also available

CHECK•LINE® – PRECISION QUALITY CONTROL INSTRUMENTS

Electromatic Equipment Co., Inc.
600 Oakland Ave.
Cedarhurst, NY 11516 —USA

Tel: (800) 645-4330 (USA & Canada)
Tel: (516) 295-4300
Fax: (516) 295-4399

Email: info@checkline.com
Website: www.checkline.com

FOR ADDITIONAL INFORMATION OR TO PLACE AN ORDER CALL TOLL FREE 1-800-645-4330