

The TSTM-DC is an advanced motorized torque test stand offering all the mechanical specifications of the TSTM. The test stand is designed for a wide variety of applications requiring up to 100 lbFin of torque, including closure torque testing, fastener torque testing, and more. Modular design allows the stand to be configured for a variety of torque sensors and gripping fixtures while a lever-operated slider with travel stops makes engaging and disengaging samples quick and efficient. The stand includes a torque loading plate with tapped holes for grip and fixture mounting. Stepper motor design eliminate speed variation with load.

The TSTM-DC's controller adds a significant amount of sophistication, including integrated angle display and output, programmable angle travel limits, an extended speed range, PC control capability, programmable cycling, auto return, overload protection, and other features.

Features / Specifications

| |
|--|
| Maximum torque: 100 lbFin [11.3 Nm] |
| Speed range: 0.01 - 15 RPM [0.05 - 90°/s] |
| Speed accuracy: $\pm 0.2\%$ of setting, $\pm 0\%$ variation with load |
| Integrated angle indication with programmable travel limits |
| Maximum programmable travel limits: $\pm 999,999.9^\circ / \pm 2,777.77$ revolutions |
| Rotational travel accuracy: $\pm 0.7^\circ$ |
| Rotational travel repeatability: 0.1° |
| Rotational travel resolution: 0.1° |
| Universal power supply: 80-250 VAC |
| Mounting holes for bench mounting |
| Base may be removed for alternative mounting |
| Grip / fixture mounting plate with 25 #10-32 threaded holes |
| Slider travel rate: 1.047" [26.6 mm] / lever rev |
| CE mark |

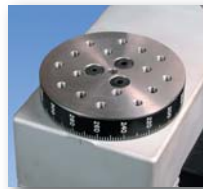

Rotating torque plate has a matrix of tapped holes for grip or fixture mounting



Optional Hardware

■ Model BGI force/torque gauge

Universal indicator for Mark-10 force and torque remote sensors. Mounts directly to the test stand.

■ Series STJ torque sensor

Mounts directly to the test stand. Capacities available from 10 ozFin to 100 lbFin.

■ Multi-function cable, BGI gauge to controller

Connects a Model BGI gauge to the controller. This single cable is used to transmit set points, overload signals, and force data.

■ Serial cable, controller to PC

For communicating with a PC for computer control. Also used to send torque and angle data to a PC.

■ Serial cable, gauge to PC

Connects a Model BGI gauge with a PC. Bypasses the controller.



The TSTM-DC is shown in a cap torque test, with a Series STJ torque sensor, BGI force/torque indicator, and G1023 universal closure grip, and G1053 cap grip



The TSTMH-DC is shown in a pen cap torque test, with a Series STJ torque sensor, BGI force/torque indicator, and G1022 Jacobs chuck grip

Controller Features

Computer Control

A bi-directional RS-232 port is provided to interface with a PC. A command set is provided to allow for full control from a PC. The following are required with PC control:

- Model BGI force/torque gauge
- 09-1056 serial cable (see Optional Equipment)
- 09-1143 multi-function cable (see Optional Equipment)

Digital Angle Indication

Rotational travel is indicated in degrees or revolutions, with RS-232 output of angle data.

Programmable Angle Limits

The TSTM-DC can stop at or cycle between programmable upper and lower angle limits. Programmable in degrees or revolutions.

Overload Protection

Protects the torque sensor against overload (requires a Model BGI force/torque gauge and 09-1143 multi-function cable). The user programs the desired percentage of full scale of the sensor.

Auto-return

The torque table rotates to an angle limit or torque set point (requires a Model BGI force/torque gauge and 09-1143 cable), stops, and reverses direction at full speed to the other angle limit or torque set point.

Cycling / Dwell Time

Same as Auto-return, but with the ability to program the number of cycles up to 99,999 cycles. Dwell time allows the operator to program the length of time, up to 9,999.9 seconds, in 0.1 second intervals, for which the torque table pauses between cycles. Independent CW and CCW speeds may be programmed.

Programmable CW / CCW Button Functions

CW and CCW button operation can be configured in three user-configurable modes: Maintained: a short push produces continuous motion until STOP is pressed, Momentary: crosshead moves only while the button is pressed, and Auto: short push produces maintained motion, while holding down the button will produce momentary motion.

Independent CW and CCW Speeds

Programmable independent speeds for clockwise and counterclockwise directions

Selectable Speed Units of Measurement (RPM and deg/s)

Password Protection

Prevents unauthorized changes to test parameters

CONTROLLER

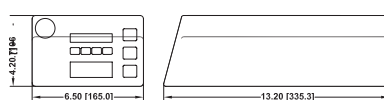

Ordering Information

| Model No. | Description |
|-----------|---|
| TSTM-DC* | Motorized torque test stand, vertical |
| TSTMH-DC* | Motorized torque test stand, horizontal |
| 09-1143 | Multi-function cable, gauge to controller |
| 09-1056 | Serial cable, controller to PC |
| 09-1048A | Serial cable, BGI gauge to PC |
| --- | Column extensions |

* For 220V operation add suffix E to model number. Ex: TSTM-DCE

TSTM-DC / TSTMH-DC test stands include a wrench set.

Dimensions

in [mm]

TSTM-DC

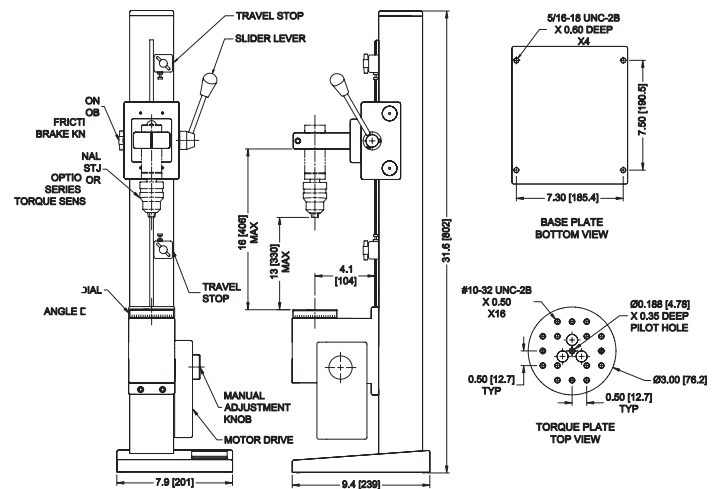

TSTMH-DC

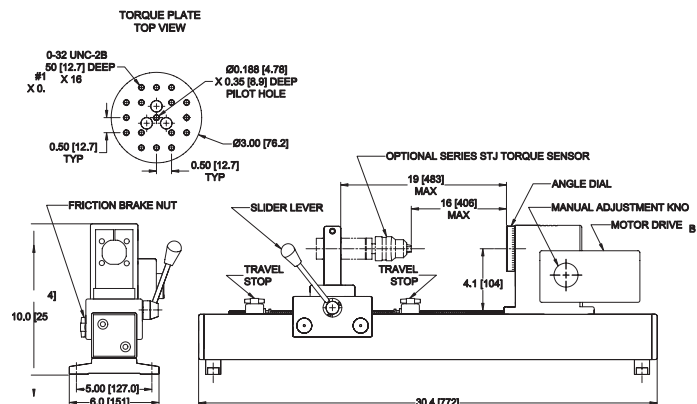

Albuquerque Industrial
69-10 108th Street # 2-O
Forest Hills, NY 11375 U.S.A.

www.abqindustrial.net
e-mail: info@abqindustrial.net
Toll Free: +1 (888) 275-5772
Tel: +1 (718) 846-6458
Fax: +1 (718) 846-6459