

6.0 SPECIFICATIONS

Calibration	According to factory procedure
Accuracy*	± 1% full scale (FS) or ± 1 graduation on scale
Scale diameter	41 mm
Temperature range	45 to 115 °F (10 - 45 °C)
Air humidity	85% RH, max.
Housing material	Die-cast aluminum
Housing dimensions (L x W x H)	8.6 in x 3.5 in x 1.7 in (188 x 85 x 45mm)
Weight (net)	Approx. 1.04 lb. (470 g)
Guide rollers	V-grooved
Line Speed	2000 m/min max.
Roller Material	Standard hardcoated aluminium

* Using factory standard materials and procedures. Special calibration using customer sample is available. Specifications subject to change without notice.

6.1 Dimensions

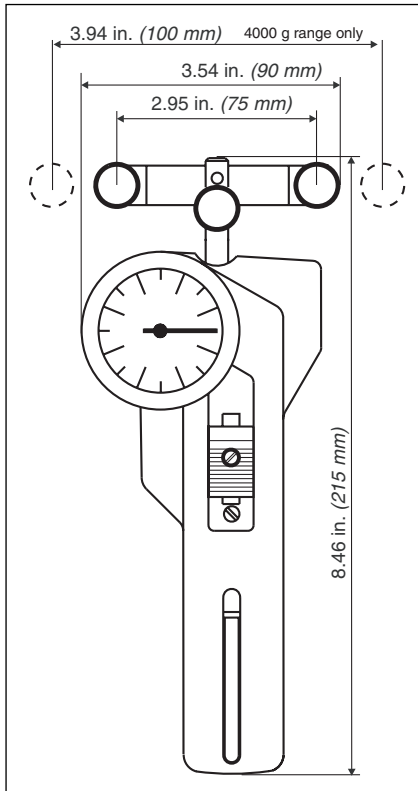

6.2 Spare Rollers

You should regularly inspect the rollers to assure that they are running easily and smoothly. You can replace the rollers yourself, as necessary. When ordering spare rollers, please indicate the tension meter model and the serial number (on the rear side of the tension meter).

Standard rollers: P/N R1000

CONTENTS

	Page
1.0 Introduction	2
1.1 Complete Kit	
1.2 Unpacking	
1.3 Tension Ranges	
2.0 Overview	3
2.1 Operating Elements	
2.2 Mounting Special Finger Support	
3.0 Taking A Measurement	4
4.0 Verifying Calibration	5
4.1 Frequency of Calibration Verification	
4.2 NIST Calibration	
5.0 Options	7
5.1 Air Dashpot Damping	
5.2 Memory Pointer	
6.0 Specifications	8
6.1 Dimensions	
6.2 Ordering Spare Rollers	
7.0 Warranty	



WARNING

The device must not be operated in explosion hazard areas and must not come into contact with aggressive substances.



WARNING

Tensions that exceed the tension range of the instrument by more than 100 % may cause permanent damage to the movement and must be avoided under any circumstances.

1.0 INTRODUCTION

DX2-EDM Tension Meters are hand-held, mechanical instruments which accurately measure the running as well as static tensions at the wire used in wire EDM machines.

The DX2-EDM employs the 3-roller principle for tension measurement where the outer two reference guide rollers remain fixed during measurement to establish a wrap angle over the middle sensing roller. The middle roller, acting against an internal calibrating spring, is displaced relative to the line tension. This displacement is converted to rotary motion to turn a pointer on a scale to give a reading in grams tension.

1.1 Complete Kit (included in shipment)

- Tension meter
- Special finger support
- Operating instructions
- Carrying case

1.2 Unpacking

Unpack the tension meter and inspect it for any shipping damage. Notices of defect must be filed within 10 days of receipt of the tension meter.

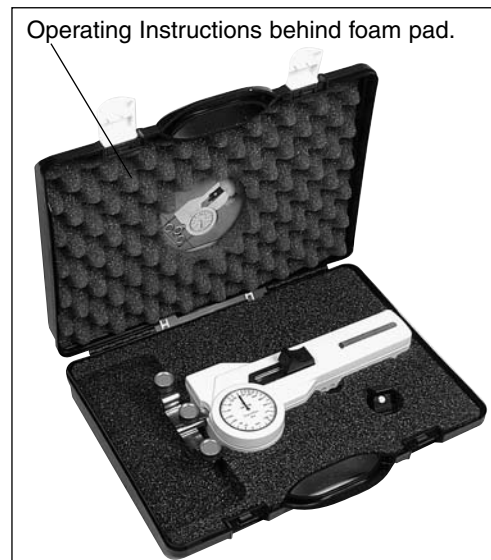

1.3 Model Ranges

Tension Ranges (cN)	Roller Distance (c:c) mm	Calibration Material
050 - 2000	75	PA: 0.30 mmØ
150 - 2200	75	PA: 0.30 mmØ
100 - 3000	75	PA: 0.30 mmØ
200 - 4000	100	PA: 0.40 mmØ

5.0 OPTIONS

5.1 Air Dashpot Damping

DX2-EDM Tension Meters incorporate a moderate amount of movement damping to smooth out some high frequency tension fluctuation. However, where process fluctuations result in rapid pointer swings which make it difficult or near impossible to read the scale, an optionally-available Air Dashpot Damping mechanism can be provided to slow down the pointer swings to permit a reading. In setting up the mechanism, it is best to set the damping rate just to the point where a readable pointer results with minimal pointer swings. The amount of damping is set by turning the small slotted screw or hex-head screw of the damping assembly located near the guide-roller mounting bracket. The Air Dashpot must be installed at time of original manufacture. It cannot be added later.

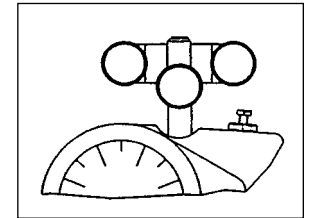

CAUTION

Do not set the damping rate too high as this will damage the instrument.

5.2 Memory Pointer

The optional Memory Pointer assembly retains the highest reading obtained during a measuring period. Before using the instrument, rotate the knurled pointer knob clockwise until the "memory" pointer tab contacts the measuring pointer at zero. During operation and after instrument removal, the trailing "memory" pointer will hold the maximum reading until reset with the pointer knob.

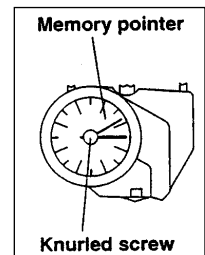

4.1 Frequency Of Calibration Verification

Frequency of calibration accuracy verification depends on many factors. These include frequency and extent of tension overloads, operating speeds, length of operating times, environment, care in handling, etc. Such determination is best made by the user's Quality Assurance Department based on the user's experience. However, a quick calibration check near the anticipated process tension levels should be done to confirm the integrity of the instrument, as follows:

1. At the beginning of each work session.
2. Every time a unit is dropped.
3. Whenever process readings seem to be out of tolerance for no apparent reason.

The quick check can be made with a simple load stand, as shown section 4.2, using a sample of the process material and weights that are close to the tensions encountered in the process. Be sure to move the tension meter up and down slowly to simulate the motion of the running process material. This will check the condition of the guide roller ball bearings and remove any inertia effect of the movement. Readings that change with this motion reversal may indicate the possibility of a guide roller ball bearing problem.

In the case of wire, which might be slightly deformed by the action of the 3- roller system during static measurement, always move to a fresh portion of the wire each time a measurement is made. (In production, the instrument always "sees" a fresh portion.)

4.2 NIST Calibration

While all DX2-EDM instruments are furnished with a Calibration Certificate which certifies that they have been calibrated in accordance with factory procedures and were found to meet all published accuracy specifications, such calibrations do not fulfill ISO-9000 requirements since no record of measured values are kept or are submitted. Where ISO-9000 requirements are to be met, NIST calibration is optionally available but must be specified at time of order placement or after repair.

2.0 OVERVIEW

2.1 Operating Elements

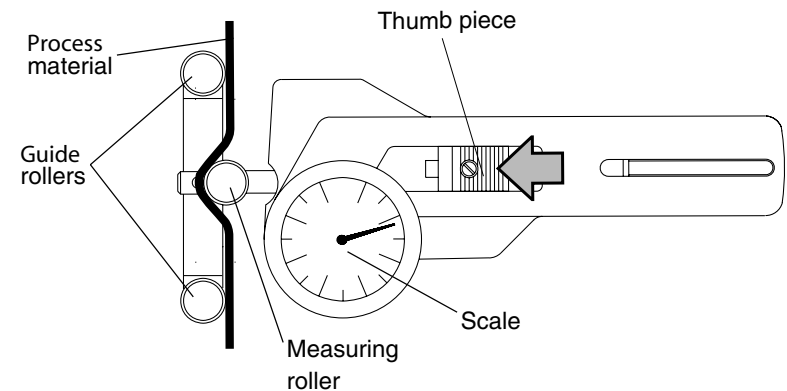

2.2 Mounting Special Finger Support

Whenever useful and necessary, the tension meter is supplied with a special finger support. We recommend mounting the finger support when measuring high tension to reduce the necessary effort to move the outer rollers with the Thumbpiece on the front of the tension meter and facilitate acquisition of the wire to be measured. Place the special finger support in the recess located on the rear side of the tension meter and fasten it with the finger support screw.

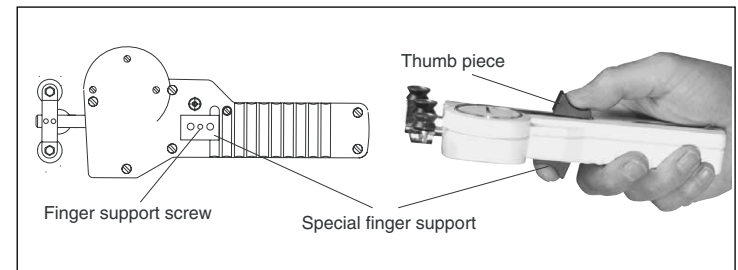

3.0 TAKING A MEASUREMENT

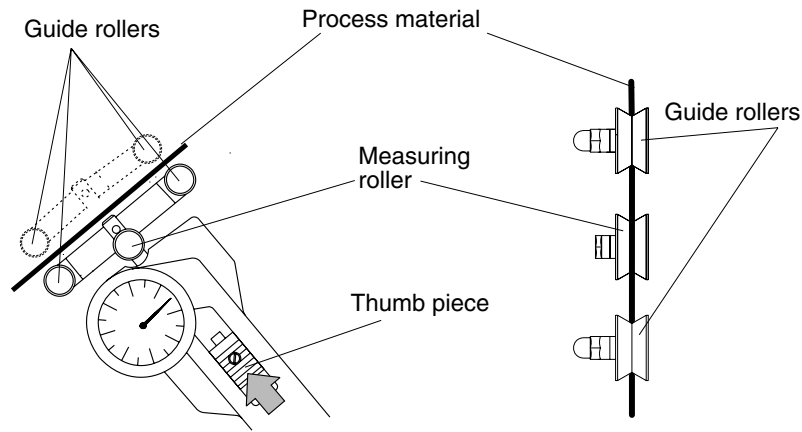

1. Prior to engaging the material under test, part the 3-roller system by pushing and holding the Thumbpiece forward—see arrow above.
2. Keeping the outer rollers extended, bring the instrument behind or under the wire and move it so that the process material is in contact with V-groove of the bottom sensing roller.
3. Slowly release pressure on the Thumbpiece until the outer rollers return to their original position. This will automatically direct the material into the guide roller grooves.
4. The scale pointer will show line tension directly in grams or kilograms.

Removal

1. To remove the instrument from the process material, push the Thumbpiece forward again to open the 3-roller system. With the outer rollers extended, move the instrument away from the material.
2. Remove the instrument and SLOWLY release pressure on the Thumbpiece, allowing the outer rollers to return to their original position.



CAUTION

Do not let the Thumbpiece snap back as this may affect calibration and also damage the instrument.

4.0 VERIFYING CALIBRATION

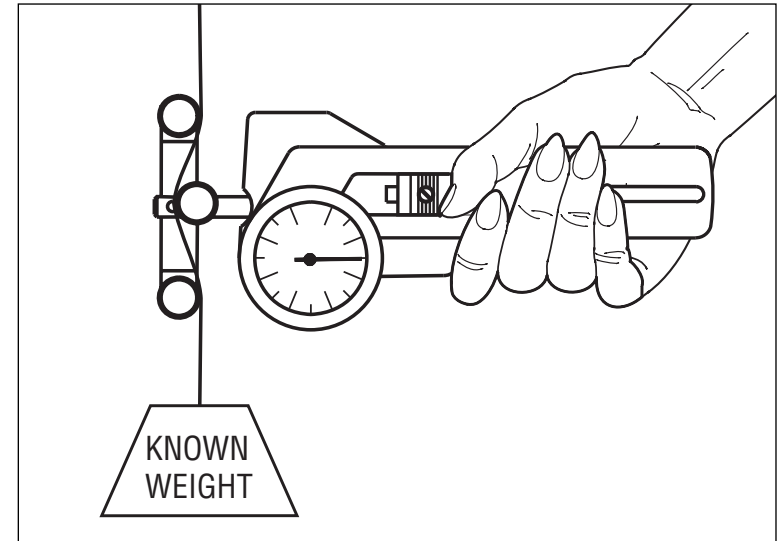

1. Suspend a known weight that corresponds to the tension to be measured (pay attention to the correct unit of measure) from the process material, vertically, see figure above.
NOTE: Always use a fresh portion of the material to be measured.
2. Push the thumbpiece as far as it will go in the direction indicated by the arrow and thread the material to be measured between the guide rollers and the measuring roller. Refer to Section 3.0.
3. Slowly release pressure on the thumb piece until the outer rollers return to their original position.
4. Before the final check, move the instrument slowly up and down to compensate any friction caused by the instrument and thus ensure repeatability.
5. The tension value should be equal to the value of the suspended weight.

If this procedure shows a deviation beyond the allowable tolerance and a reliable operation is no longer allowed, the instrument has to be recalibrated or repaired. For recalibration, return the tension meter to the factory.

7.0 WARRANTY

ELECTROMATIC Equipment Co., Inc. (ELECTROMATIC) warrants to the original purchaser that this product is of merchantable quality and confirms in kind and quality with the descriptions and specifications thereof. Product failure or malfunction arising out of any defect in workmanship or material in the product existing at the time of delivery thereof which manifests itself within one year from the sale of such product, shall be remedied by repair or replacement of such product, at ELECTROMATIC's option, except where unauthorized repair, disassembly, tampering, abuse or misapplication has taken place, as determined by ELECTROMATIC. All returns for warranty or non-warranty repairs and/or replacement must be authorized by ELECTROMATIC, in advance, with all repacking and shipping expenses to the address below to be borne by the purchaser.

THE FOREGOING WARRANTY IS IN LIEU OF ALL OTHER WARRANTIES, EXPRESSED OR IMPLIED, INCLUDING BUT NOT LIMITED TO, THE WARRANTY OF MERCHANTABILITY AND FITNESS FOR ANY PARTICULAR PURPOSE OR APPLICATION. ELECTROMATIC SHALL NOT BE RESPONSIBLE NOR LIABLE FOR ANY CONSEQUENTIAL DAMAGE, OF ANY KIND OR NATURE, RESULTING FROM THE USE OF SUPPLIED EQUIPMENT, WHETHER SUCH DAMAGE OCCURS OR IS DISCOVERED BEFORE, UPON OR AFTER REPLACEMENT OR REPAIR, AND WHETHER OR NOT SUCH DAMAGE IS CAUSED BY MANUFACTURER'S OR SUPPLIER'S NEGLIGENCE WITHIN ONE YEAR FROM INVOICE DATE.

Some State jurisdictions or States do not allow the exclusion or limitation of incidental or consequential damages, so the above limitation may not apply to you. The duration of any implied warranty, including, without limitation, fitness for any particular purpose and merchantability with respect to this product, is limited to the duration of the foregoing warranty. Some states do not allow limitations on how long an implied warranty lasts but, notwithstanding, this warranty, in the absence of such limitations, shall extend for one year from the date of invoice.

ELECTROMATIC Equipment Co., Inc.
600 Oakland Ave. Cedarhurst, NY 11516—USA
Tel: 1-800-645-4330/ Tel: 516-295-4300/ Fax: 516-295-4399

Every precaution has been taken in the preparation of this manual. Electromatic Equipment Co., Inc., assumes no responsibility for errors or omissions. Neither is any liability assumed for damages resulting from the use of information contained herein. Any brand or product names mentioned herein are used for identification purposes only, and are trademarks or registered trademarks of their respective holders.

HAND-HELD TENSION METER DX2-EDM

