NOTES

Table of Contents

1.0 Introduction	2
1.1 Package Contents	
2.0 Safety Instructions	2
3.0 Overview	3
4.0 Assembly and Connection	4
4.1 Typical Wiring Connections	
5.0 Operation	6
5.1 Key Assignments	
5.2 Influencing the trigger signal before output to a stroboscope	
5.3 Units	
5.4 Operating Notes	
6.0 Hints and Suggestions	9
7.0 Specifications	10
8.0 Warranty	11

1.0 INTRODUCTION

Congratulations on your purchase of a Checkline® LS-5-RCU Remote Control Unit for Linear Stroboscope. The LS-5-RCU provides an easy-to-use control center for any stroboscope whether it is from Electromatic or other manufacturers. Use it to create a trigger signal or to influence a signal generated externally. The multiplicity of control parameters make it easy for you to carry out the inspection or measurement tasks required of you.

NOTE: When using a stroboscope, remember that while objects may appear to become motionless, they are, in fact, still moving. Exercise proper care to prevent injury.

Please read this instruction manual thoroughly before operating your remote control unit. If you have any questions not answered by this manual, call your local supplier, or visit our web chat interface at www.checkline.com for full product support.

1.1 Package Contents



The LS-5-RCU Remote Control Unit is shipped fully assembled in a hard-plastic carrying case. Your package should contain the following:

- LS-5-RCU Remote Control Unit
- Trigger cable (1.5m)
- Operating instructions
- Certificate
- Case

After unpacking, please examine your control unit for signs of mishandling during shipping. If damage has occurred, contact Electromatic before attempting to plug in the instrument. Notify your shipping carrier immediately for damage claim instructions.

2.0 SAFETY

- When using a stroboscope, remember that objects may appear to become motionless, but they are still moving. Exercise proper care to prevent injury.
- Do not look directly at the emitted light from a stroboscope; it can damage your eyes. It may also trigger seizures in people with epilepsy.
- The LS-5-RCU must not be used in explosion hazard areas.
- Store the LS-5-RCU in dry conditions.

12.0 WARRANTY

ELECTROMATIC Equipment Co., Inc. (ELECTROMATIC) warrants to the original purchaser that this product is of merchantable quality and confirms in kind and quality with the descriptions and specifications thereof. Product failure or malfunction arising out of any defect in workmanship or material in the product existing at the time of delivery thereof which manifests itself within one year from the sale of such product, shall be remedied by repair or replacement of such product, at ELECTROMATIC's option, except where unauthorized repair, disassembly, tampering, abuse or misapplication has taken place, as determined by ELECTROMATIC. All returns for warranty or non-warranty repairs and/or replacement must be authorized by ELECTROMATIC, in advance, with all repacking and shipping expenses to the address below to be borne by the purchaser.

THE FOREGOING WARRANTY IS IN LIEU OF ALL OTHER WARRANTIES, EXPRESSED OR IMPLIED, INCLUDING BUT NOT LIMITED TO, THE WARRANTY OF MERCHANTABILITY AND FITNESS FOR ANY PARTICULAR PURPOSE OR APPLICATION. ELECTROMATIC SHALL NOT BE RESPONSIBLE NOR LIABLE FOR ANY CONSEQUENTIAL DAMAGE, OF ANY KIND OR NATURE, RESULTING FROM THE USE OF SUPPLIED EQUIPMENT, WHETHER SUCH DAMAGE OCCURS OR IS DISCOVERED BEFORE, UPON OR AFTER REPLACEMENT OR REPAIR, AND WHETHER OR NOT SUCH DAMAGE IS CAUSED BY MANUFACTURER'S OR SUPPLIER'S NEGLIGENCE WITHIN ONE YEAR FROM INVOICE DATE.

Some State jurisdictions or States do not allow the exclusion or limitation of incidental or consequential damages, so the above limitation may not apply to you. The duration of any implied warranty, including, without limitation, fitness for any particular purpose and merchantability with respect to this product, is limited to the duration of the foregoing warranty. Some states do not allow limitations on how long an implied warranty lasts but, notwithstanding, this warranty, in the absence of such limitations, shall extend for one year from the date of invoice.

ELECTROMATIC Equipment Co., Inc.

600 Oakland Ave. Cedarhurst, NY 11516—USA

Tel: 1-800-645-4330/ Tel: 516-295-4300/ Fax: 516-295-4399

Every precaution has been taken in the preparation of this manual. Electromatic Equipment Co., Inc., assumes no responsibility for errors or omissions. Neither is any liability assumed for damages resulting from the use of information contained herein. Any brand or product names mentioned herein are used for identification purposes only, and are trademarks or registered trademarks of their respective holders

8.0 SPECIFICATIONS - LS-5-RCU

Signal Resolution

Frequency	30.0 to 999.9 FPM ± 0.1 0.5 to 999.9 Hz ± 0.1 1.000 to 600.000 FPM ± 1 1.000 to 10.000 Hz ± 1
Pulse width	Can be set as absolute ($\pm 1\mu\text{s}$) or relative ($\pm 1^\circ$)
Phase shift	0 to $359^\circ \pm 1^\circ$
Delay	0.0. to 2000.0 ms ± 0.1 ms
Divider	1. to 255 ± 1

Trigger Input

Principle	Optocoupler, voltage-free
Level	3 to 32 V, NPN + PNP
Low level	< 1 V
Minimum pulse length	50 μs
Reverse voltage protection	yes

Trigger Output

Principle	Short-circuit and overvoltage proof transistor output to optocoupler control, non-isolated
Level	NPN, max. 32 V
Pulse length	Adjustable
Maximum current	50 mA
Reverse voltage protection	yes

General

Housing Material	ABS / EPDM
Size	6.4 x 3.3 x 1.6" (162 x 82 x 40mm)
Weight	8.11 oz (230 g)
Ambient temperature	32 to 122 °F (0 to 50 °C)
Media resilience	Max. 95% air humidity, non-condensing
Protection system	IP30
Power Supply voltage	10-32 V DC, with reverse polarity protection
Current consumption	< 50 mA

3.0 OVERVIEW

For a full explanation of key functions, see page



Optional Accessories

- Power supply unit
- Mounting device
- Extension cable for trigger connection
- Adapters for stroboscopes from other manufacturers
- Electromatic stroboscopes of different types

4.0 ASSEMBLY AND CONNECTION

The power can be supplied either via the installation under observation or the stroboscope's own power supply. Alternatively, power can be supplied via a power supply unit (optional).

The function of the stroboscope control unit is to control a stroboscope. In addition, it can be used to influence an incoming trigger signal from an external system.

This device has two jacks. Power can be supplied via either of these jacks. The jack for trigger input from an external system or sensor is labeled IN. The jack for trigger output to a stroboscope is labeled OUT. The position of the jacks is indicated in (Fig. 1). The wiring of the connectors is shown in (Fig. 2)

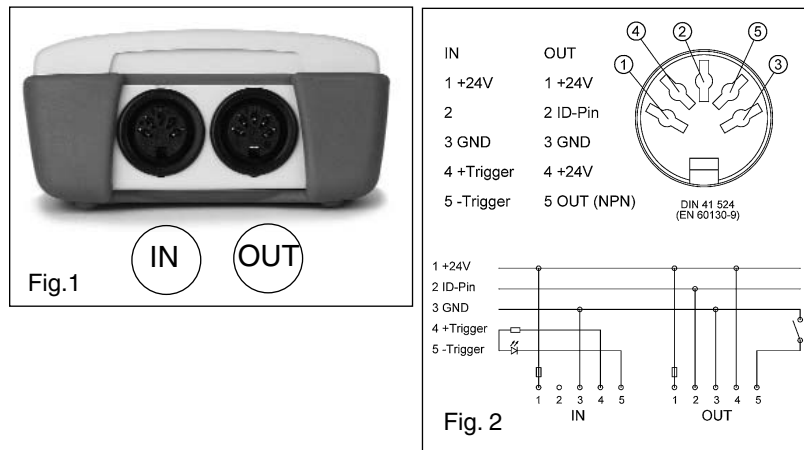

4.1 Typical Wiring Options

Please see Figs. 3-6 for examples of wiring options. Please note that you need optional accessories for the examples (such as a stationary stroboscope, power supply unit or sensor).

Fig 3. Trigger signal from this instrument. Power supply from the power supply unit (optional).

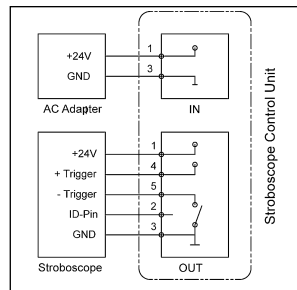

5.0 HINTS AND SUGGESTIONS

Problem: *The trigger signal is generated before the required observation point.*

Result: The stroboscope flashes too early.

Solution: Set a time delay between the input and output signals in ms steps until the stroboscope delivers the required view.

Problem: *Your equipment is consistently transmitting the trigger signal before location to be observed. However, your equipment runs at different speeds.*

Result: Your stroboscope flashes at different locations, some of which are unusable.

Solution: Use phase shift (in degrees) to permanently shift the flash position. The stroboscope will now adapt automatically to changing speeds and will flash at a location which is shifted by the set angle.

Problem: *An external trigger (e.g. a sensor) is monitoring a gear-wheel. Its frequency is many times greater than the required flash frequency.*

Result: You don't receive the required control image.

Solution: Instead of using each input signal, the impulse divider only triggers a flash impulse after every 10th, 25th or 255th input signal. Set the value in key steps or in "continuous flow" mode until the required result is displayed.

Problem: *You need measurement values to be displayed in a variety of formats.*

Solution: You have the following options: the instrument can display FPM, RPM or Hz.

5.3 Units (see diagram on page 6)

8 FPM: Flashes per minute.

9 1/min: Rotations per minute.

10 Hz: Frequency of movement per second.

5.4 Operating Notes (see diagram on page 6)

12 RANGE: External trigger signal out of range 13 EXT External trigger signal selected.

14 INT: Flash frequency generated by instrument.

NOTE: Any parameter deviating from the default setting will blink during operation.

NOTE: In external trigger signal operation, the display will be in these units: 1/min (instead of FPM) or Hz.

Fig 4. Trigger signal and power supply from external installation.

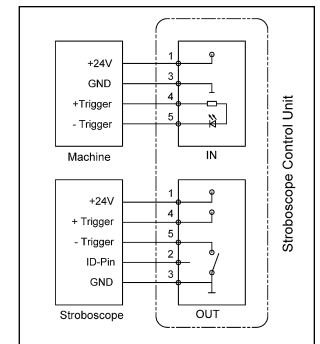

Fig 5 Trigger signal from this instrument. Power supply from the stroboscope (optional).

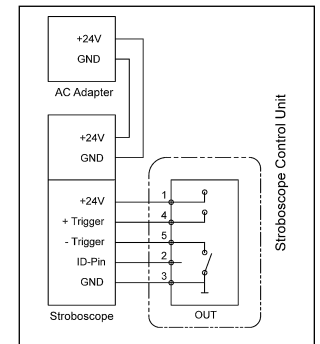
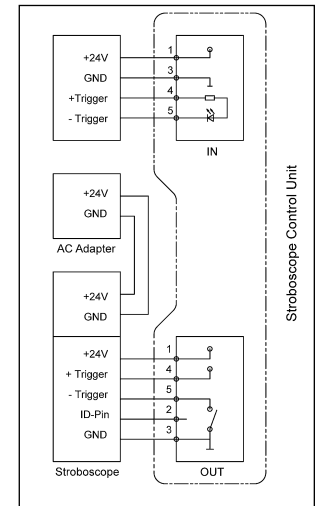
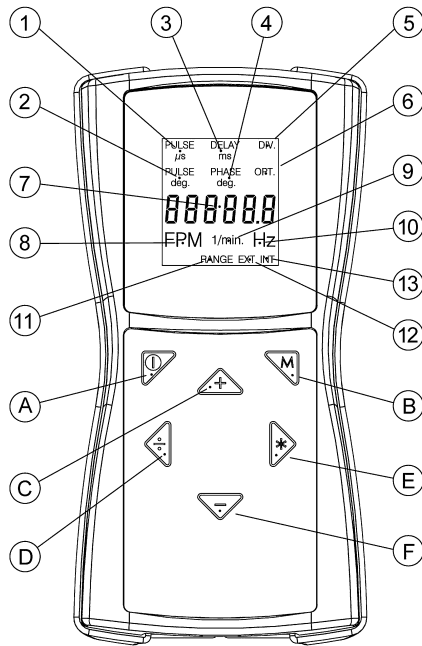

Fig 6 Trigger signal from sensor (optional), power supply for this instrument from stroboscope (optional). Sensor power supply via this instrument.



The power can be supplied either via the instrument's power supply unit (available as an option) or via the installation under observation.

5.0 OPERATION



5.1 Key Assignments

- A** On / Off
- B** Mode key. Use this key to switch between different setting options and operation modes in the sequence shown in the display above (numbers 1-10)
- C** Increases the currently selected value. Keep this key pressed down to move faster in the selected direction.
- D** Halves the currently selected value. Keep this key pressed down to move faster in the selected direction.
- E** Doubles the currently selected value. Keep this key pressed down to move faster in the selected direction.
- F** Reduces the currently selected value. Keep this key pressed down to move faster in the selected direction.

Use key combinations to command the following functions: Always press the two keys at the same time.

- B + D** To switch between an internal and external trigger signal.
- B + F** To reset to the default settings.
- A + F** To activate / deactivate key lock.

5.2 Influencing the trigger signal before output to a stroboscope

- 1, 2 PULS µs / PULS deg:** Duration of output signal pulse (in microseconds). Use this function to set the output signal pulse duration. This may be necessary, if the default short pulse duration is inadequate for control of the connected stroboscope. You can make this setting either in absolute terms (microseconds) or in relative terms (degrees).
- 3 DELAY ms:** Setting the delay time between input and output signal (in milliseconds). Use this value to set a fixed delay time between input signal and output signal.

Example: The trigger signal is generated at a position in front of the desired observation point (= stroboscope flash position). In this situation, the connected stroboscope would regularly flash too early. Use DELAY ms to set the value in order to delay the output signal.
- 4 PHASE deg:** Setting the phase shift (in degrees, relative to frequency) between input and output signal. Use this value to set a fixed angle between input signal and output signal.

Example: The trigger signal is generated at a position in front of the desired observation point (= stroboscope flash position). In this situation, the connected stroboscope would regularly flash too early. Use PHASE deg to set the delay to make the stroboscope flash at a position which is shifted by the set angle. This setting is independent of the current rotational speed. In this way, it is possible to trigger a stroboscope flash even if the rotational speed is fluctuating or when starting up the installation.
- 5 DIV (Pulse Divider):** This function is only active in the presence of an external trigger signal. Use the pulse divider to set a value x. The external trigger signal is then divided by this value.

Example: An external trigger (e.g. rotational speed sensor) monitoring a gear wheel delivers a signal for each tooth. If the DIV value = 10, only every 10th input pulse is delivered as an output signal to a connected stroboscope.
- 6 OPT:** Trigger signal edge selection. 0 = positive edge, 1 = negative edge. Use this option to define the polarity of the trigger signal.
- 7 Display:** For units, see 5.3.

LS-5-RCU

REMOTE CONTROL UNIT

FOR LINEAR STROBOSCOPES



Operating Instructions