

1.0	Introduction	4
	1.1 Standard Features	
	1.2 Accessories Included	
2.0	Overview	5
	2.1 Main Unit	
	2.2 LCD Display	
3.0	Setup	7
	3.1 Battery management	
	3.2 Using Measurement Accessories	
	3.3 Using The Hanger	
	3.4 Using The Tracking Function	
4.0	Function Modes	9
	4.1 Measurement Polarity	
	4.2 Display Update (f02)	
	4.3 Auto Power Off (f03)	
	4.4 Baud Rate (f04)	
	4.5 Response Time (05)	
	4.6 External Output (f06)	
5.0	Reversing The Display	12
6.0	Measuring Modes	13
	6.1 Standard Measuring Mode	
	6.2 Peak Measuring Mode	
	6.3 Changing Display Units	
	6.4 Tare	
7.0	Comparator	15
	7.1 Memory Setting Mode	
	7.2 Setting HI Limits	
	7.3 Setting LO Limits	
	7.4 Comparator Display	
	7.5 Comparator Output	
8.0	Setting Memory Mode / Recording Data	17
	8.1 Retting The Memory Mode	
	8.2 Recording Memory Data	
9.0	Reviewing Memory Data	21
	9.1 Continuous Mode Memory	
	9.2 Single Memory Mode	
10.0	Clearing The Memory	26
	10.1 Clearing The Last Record	
	10.2 Clearing All Memory	
	10.3 No Recorded Data	
11.0	USB Communications	27
	11.1 USB and Battery Life	

12.0	External Data Port	28
	12.1 Pin Assignment	
	12.2 RS-232C Output	
	12.3 RS-232C Communications Commands	
	12.4 Connection Between FGV and Host	
	12.5 Analog Output	
	12.6 Overload / Comparator Output	
13.0	Troubleshooting / Technical Questions	32
14.0	Specifications	33
15.0	Dimensional Drawings	34
16.0	Warranty	35

16.0 WARRANTY

ELECTROMATIC Equipment Co., Inc. (ELECTROMATIC) warrants to the original purchaser that this product is of merchantable quality and confirms in kind and quality with the descriptions and specifications thereof. Product failure or malfunction arising out of any defect in workmanship or material in the product existing at the time of delivery thereof which manifests itself within one year from the sale of such product, shall be remedied by repair or replacement of such product, at ELECTROMATIC's option, except where unauthorized repair, disassembly, tampering, abuse or misapplication has taken place, as determined by ELECTROMATIC. All returns for warranty or non-warranty repairs and/or replacement must be authorized by ELECTROMATIC, in advance, with all repacking and shipping expenses to the address below to be borne by the purchaser.

THE FOREGOING WARRANTY IS IN LIEU OF ALL OTHER WARRANTIES, EXPRESSED OR IMPLIED, INCLUDING BUT NOT LIMITED TO, THE WARRANTY OF MERCHANTABILITY AND FITNESS FOR ANY PARTICULAR PURPOSE OR APPLICATION. ELECTROMATIC SHALL NOT BE RESPONSIBLE NOR LIABLE FOR ANY CONSEQUENTIAL DAMAGE, OF ANY KIND OR NATURE, RESULTING FROM THE USE OF SUPPLIED EQUIPMENT, WHETHER SUCH DAMAGE OCCURS OR IS DISCOVERED BEFORE, UPON OR AFTER REPLACEMENT OR REPAIR, AND WHETHER OR NOT SUCH DAMAGE IS CAUSED BY MANUFACTURER'S OR SUPPLIER'S NEGLIGENCE WITHIN ONE YEAR FROM INVOICE DATE.





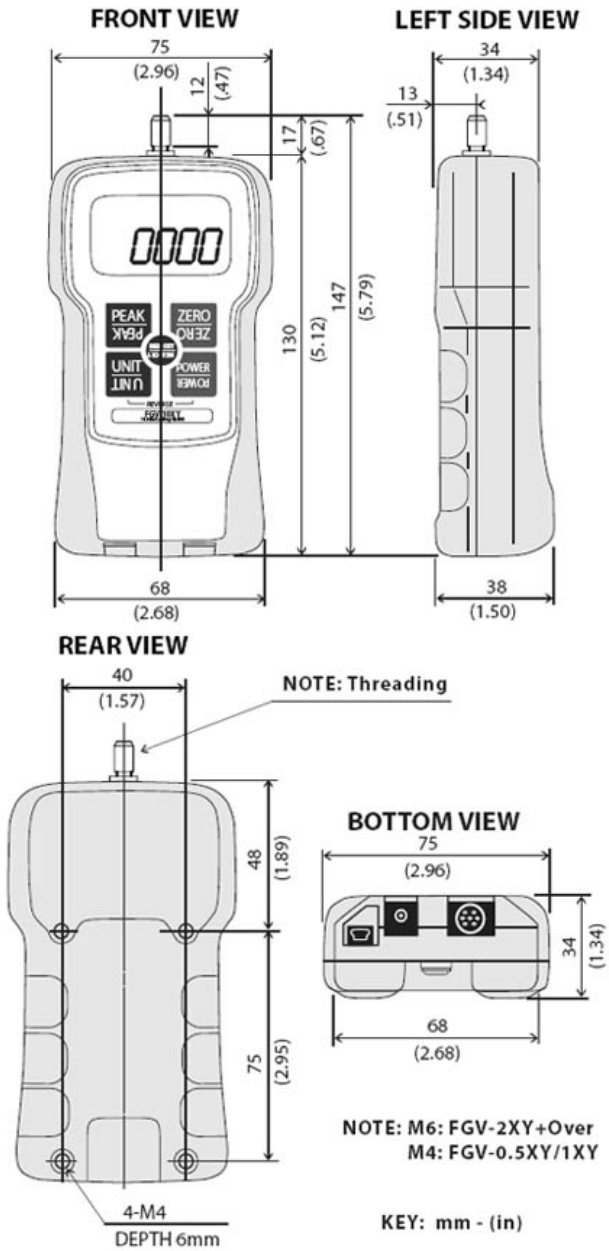

Some State jurisdictions or States do not allow the exclusion or limitation of incidental or consequential damages, so the above limitation may not apply to you. The duration of any implied warranty, including, without limitation, fitness for any particular purpose and merchantability with respect to this product, is limited to the duration of the foregoing warranty. Some states do not allow limitations on how long an implied warranty lasts but, notwithstanding, this warranty, in the absence of such limitations, shall extend for one year from the date of invoice.

ELECTROMATIC Equipment Co., Inc.
600 Oakland Ave. Cedarhurst, NY 11516—USA
Tel: 1-800-645-4330/ Tel: 516-295-4300/ Fax: 516-295-4399

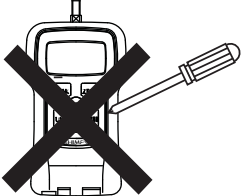
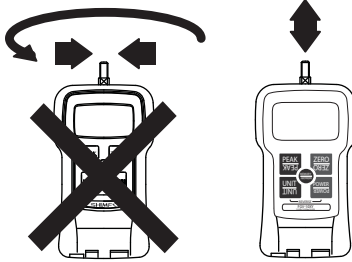
Every precaution has been taken in the preparation of this manual. Electromatic Equipment Co., Inc., assumes no responsibility for errors or omissions. Neither is any liability assumed for damages resulting from the use of information contained herein. Any brand or product names mentioned herein are used for identification purposes only, and are trademarks or registered trademarks of their respective holders.

15.0 DIMENSIONAL DRAWINGS



 Caution	
<p>Do not press the buttons on the FGV-XY with any objects other than your fingers.</p> 	<p>Do not apply side loads or torque to your FGV-XY.</p>  <p>Your FGV-XY has an internal mechanism which helps prevent overloading when the measured force is applied in line with the sensor shaft. Applying a twisting, bending or perpendicular force to the shaft will result in permanent damage, and inaccurate measurements.</p>
<p>Avoid dropping your FGV-XY.</p>  <p>Your FGV-XY is not designed to withstand dynamic loads. A fall of sufficient height can permanently damage your gauge.</p>	<p>Do not use your force gauge in, or around water.</p>  <p>Your FGV-XY is not waterproof, and is not designed for wet, or excessively humid locations.</p>
<p>Measuring small loads.</p> <p>Turn off Tracking function before measuring small forces. Refer to section "4.4. Tracking" for more information.</p> 	<p>OVR is displayed when the gauge is overloaded. Remove the load immediately to avoid damage. Any measurement during the OVR condition is not accurate.</p> 
<p> Loading the FGV-XY with a force greater than its rated capacity can damage the gauge.</p>	

1.0 INTRODUCTION

The all new FGV-XY series force gauge delivers industry-leading value with an extensive list of features including USB output, reversible display and a rugged metal housing. Each gauge is supplied as a complete kit with several screw-on adapters providing a complete force testing instrument for use in a wide variety of industries. All models include built-in memory for 1000 values, easily downloaded via the USB data output to a PC using the software & cable supplied at no charge.

1.1 Standard Features

- Nickel-Hydrogen battery allows long periods of use.
- Data can be downloaded to PC via USB.
- 1000 points of data storage.
- Comparator feature for pass/fail testing.
- Broad range of capacities:
2.000N (200.0gf, 8 oz.) ~ 1000N (100.0gf, 200 lb).
- Reversible display with reversed keypad for upside down reading
- One touch operation to change the measurement unit N (kg (g), Lb (oz)).
- Measures peak values for tension and compression.
- High speed measurement rate of 1000 times/second.
- Display update time as fast as 20 times/second.

1.2 Accessories Included

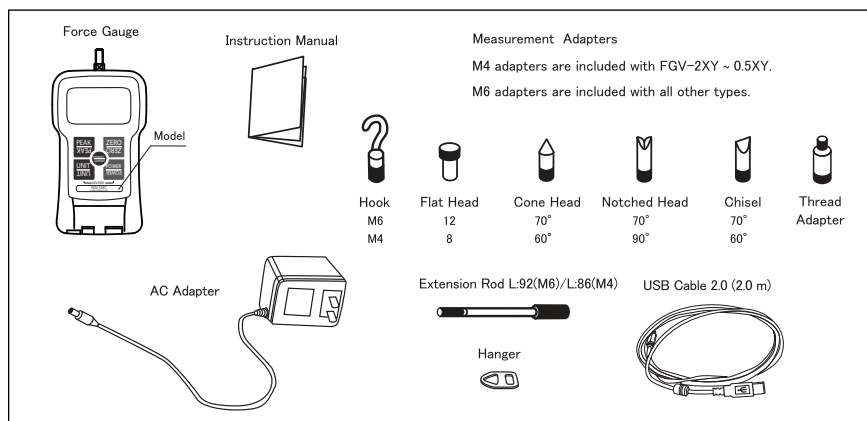

14.0 SPECIFICATIONS

Measuring Modes	Realtime, Compression Peak, Tension Peak
Display Update Rate	User Selectable: 1, 2, 3, 5, 10, 20 times per second
Sampling Rate	1000 times per second (1000Hz/1KHz)
Accuracy	± 0.2% F.S.
Temperature Drift	Gain : ± 0.01% LOAD / Zero : ±0.01% / R.C. / Drift of zero point can be cancelled with tracking function.
Display	Main display: 4-digits 12mm high, Reversible Units display: 3-digits 7mm high
Overload	200% of Full Scale On Model FGV-200XY: 150% F.S.
Tracking	User Selectable (ON/OFF)
USB Output	Allows communication between FGV-XY and Windows PC Software with ToriemonUSB via USB cable(included).
RS-232C Output	Allows communication between the FGV-XY and RS-232C devices.
Analog Output	± 1V, Accuracy is ± 50mV through a 12 bit D/A. ZERO affects this output, and is updated at 1000 times/second. Load is >10k Ohms
Overload/Comparator	Open-collector output (Max DC30V/5mA). Output
Power	Rechargeable Nickel hydride battery or AC adapter/charger.
Operating Time	Approximately 8 hours after a full charge. Charging Time: 16 Hours Max.
Auto Power Off	Default is 10 minutes. Can be disabled. Automatically disabled when connected to AC adapter.
Memory function	Continuous memory: 1000 data points, Single memory: 100 data points, Standard memory: 50 data points Statistics functions (max, minimum, peak, average, standard deviation)
Comparator function	User Selectable: HI and LO
Temperature range	-32 ~ 104° F (0 ~ 40° C)
Humidity range	35 ~ 85% RH
Dimensions	5.79" (L) x 2.95" (W) x 1.50 (H) (147 x 75 x 38mm)
Weight	Approx. 15.87 oz. (450g) On Model FGV-200XY: Approx.17.64 oz. (500g)
Software	Free application software (USB version) available at www.checkline.com/products/126333/fgv-xy_software_manual.zip

13.0 TROUBLESHOOTING / TECHNICAL QUESTIONS

Questions	Cause	Presumable reason	Procedure
At power on, "OVR" is displayed without any load.	Load cell damage	The damage may have occurred from a drop, dynamic load, or extreme overload.	Contact your Shimpo dealer for repair information.
"LO BAT" is still displayed after 16 hours of charging.	Low battery voltage Charging circuit malfunction AC adapter malfunction	Battery will no longer charge AC Adapter / PCB damaged from misuse	Contact your Shimpo dealer for repair information.
Unit will not power up under battery power.	Low battery voltage Charging circuit malfunction AC adapter malfunction	Battery will no longer charge AC Adapter / PCB damaged from misuse	Contact your Shimpo dealer for repair information.
While connected to the AC adapter, "BAT" is not displayed.	Charging circuit malfunction AC adapter malfunction	AC Adapter / PCB damaged from misuse	Contact your Shimpo dealer for repair information.
When measuring small forces, the display zeros itself.	Tracking Function Section 4.4	Tracking is on, and zeros the small forces because it looks like a temperature change.	Turn off Tracking, Section 4.4
The measurement value changes with the orientation of the gauge.	Weight of the sensor shaft.	The gauge is measuring the small weight of the sensor shaft which is connected to the load cell.	Press ZERO after the gauge is in position to negate any discrepancies due to the sensor shaft's weight.
The software, Toriemon, doesn't work with my FGV-XY.	Toriemon isn't compatible with the FGV-XY.	Toriemon is only compatible with DART and JAVELIN series gauges.	Download ToriemonUSB from the following website.

Questions	Explanation	Reference
How long should my FGV-XY's battery last?	The nickel metal hydride battery should last for 500 full charge cycles, and should optimally last 8 hours on a full charge.	Please charge battery after discharging electricity until "LO BAT" is displayed at LCD.
What is the reason for different capacity gauges?	To obtain the best accuracy in each situation, different capacities are available.	To achieve the best accuracy, choose a gauge that will allow most of your measurements to fall within 50 - 100% of the gauge's rated capacity.
Why does measuring data show variations?	Although there are many reasons, the measuring value is affected by vibration if you hold by hands.	Fluctuation will be reduced when using stand.
How does side loading and torque affect the gauge's readings?	Side loading and torque effects are not measurable, can damage the internal components, and will void your warranty.	
How are the force gauges calibrated?	The FGV-XY is calibrated using dead weights at the factory.	Contact your Shimpo dealer for information regarding NIST certification for your gauge.
Is the battery user servicable?	The internal battery is not user servicable.	Please contact your Shimpo dealer regarding battery replacement, and repair.
Do you have CAD or technical drawings available?	CAD and technical drawings are available for the FGV-XY.	Please contact your Shimpo dealer for information regarding CAD and technical drawings.
Is the FGV-XY case waterproof?	No, the case is not waterproof or water resistant. Do not use in or around water or high levels of humidity or condensation.	

2.0 OVERVIEW

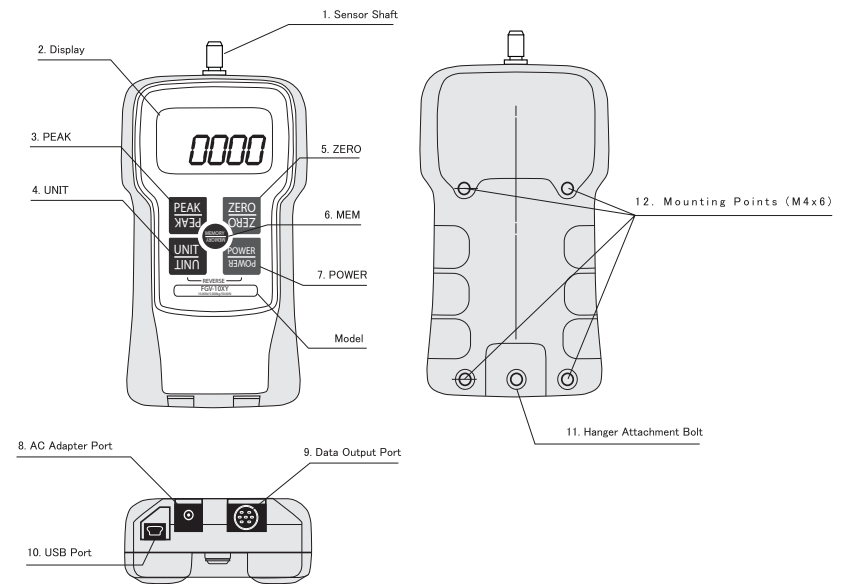

2.1 Main Unit

1. **Sensor Shaft** Apply your force in line with this threaded shaft, using the included attachments,
2. **Display** LCD screen is the main information display
3. **PEAK** Press to change the measuring modes
4. **UNIT** Press to switch to available measurement units
5. **ZERO** Press in Standard mode to tare gauge. Pressing in PEAK mode clears the current peak value
6. **MEM** Press in Standard mode to activate measurement recording
7. **POWER** Press to turn the gauge on and off
8. **AC Adapter Port** Used for the provided AC Adapter
9. **Data Output Port** Used for data output option
10. **USB Port** Used to connect gauge to PC via USB
11. **Hanger Attachment Bolt** Secures the provided hanger attachment
12. **Threaded Holes** Used to attach gauge to fixture or stand

2.2 LCD Display

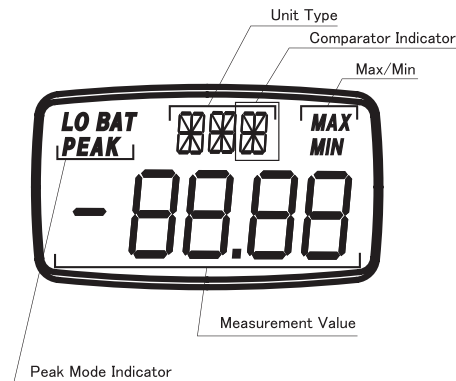

Note: The default setting for the four digit displays shows compression loads as a positive force and tension loads as a negative force. to reverse these settings, showing compression loads as negative and tension loads as positive, see section 4.1 for setting f01.

2.3 Display Indicators

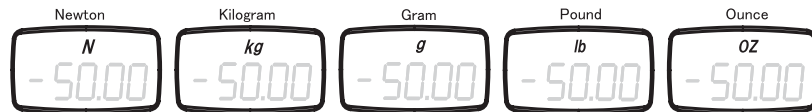

The availability of kg or g, and lb or oz is determined by the gauge's capacity.



OVR is displayed when the load has exceeded the gauge's capacity by 20%.

PWR is displayed 1 minute before the gauge automatically powers off.

Δ and ∇ are shown when the comparator is active. See section 5.5.5 for more information.



LO BAT flashes when the battery needs to be charged. Plug in the supplied AC adapter.

BAT is displayed when the battery is being charged.

PEAK is displayed when the unit is in Peak mode. The presence of "-" confirms negative Peak mode.

2.4 MAX/MIN display

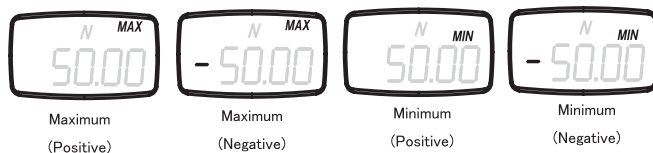

Maximum (Positive)

Maximum (Negative)

Minimum (Positive)

Minimum (Negative)

Overload Output

When the overload condition is triggered, the corresponding overload output turns on. this can be used to stop a motorized test stand, or an alarm to prevent damage from accidental overload.

When compression overload occurs photo-couple 1 (PC1) turns on, and allows current to flow between pins 8 and 10.

When tension overload occurs photo-couple 2 (PC2) turns on and allows current to flow between pins 9 and 10.

If no overload condition exists, PC1 and PC2 should be closed and will not allow current flow.

Overload occurs at about 120% of the gauge's rated capacity. this includes any weight zeroed during any tare operation.

Comparator Output

When the LO limit is reached, photo-couple 1 (PC1) turns on and allows current to flow between pins 8 and 10.

When the HI limit is reached, photo-couple 2 (PC2) turns on and allows current to flow between pins 9 and 10.

Refer to section 7 regarding the activation and setting of Comparator limits.

12.5 Analog Output

±1 V analog output. The output voltage's polarity corresponds to the polarity shown on the display during standard measurement mode.

Output signal	± 1V
Signal method	12 bit D/A converter
Output update	1000 times/second*
Load resistance	>10 k Ω
Output accuracy	± 50mV

*This rate is determined by setting f05.

The analog output has a default update rate of 1000 time/second. The output voltage is linearly scaled so that the current zero point of the gauge corresponds with 0V, and so that 1V corresponds with 100% of the gauge's rated capacity. This means that the tare function, or any change in the gauge's zero point, will change the maximum voltage shown before the gauge is overloaded.

12.6 Overload/Comparator Output

Output overload/comparator signal.
Switch of output overload/comparator signal is set by external output setting (f06) of function mode.

I/F Circuit

Compression Overload /
LO Comparator Trigger

Tension Overload /
HI Comparator Trigger

Common
(For Pins 8 and 9)

Pin 8

Pin 9

Pin 10

! 30V / 5mA Maximum

3.0 SETUP

3.1 Battery Management

IMPORTANT: Use only the AC Adapter supplied with your FGV-XY. Do not use a third party adapter. Doing so could cause a fire or shock hazard.

- To charge your FGV-XY, firmly plug the AC Adapter into the gauge's power port and then plug the Adapter into a wall outlet.
- Charging begins automatically. **BAT** appears on the display during charging and disappears when charging is complete.

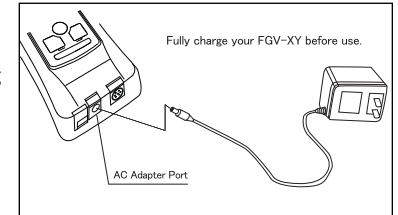

NOTE: Charging time is up to 16 hours. Operating time on full charge is approximately 8 hours. The FGV-XY is operable during charging

- When battery power runs low, **LO BAT** appears on the display. If the gauge is not plugged into an AC outlet, it will power off in approximately one minute.

NOTE: Only charge the battery when **LO BAT** appears on the display. Charging the unit before the battery is close to empty decreases battery life.

3.2 Using the Measurement Accessories

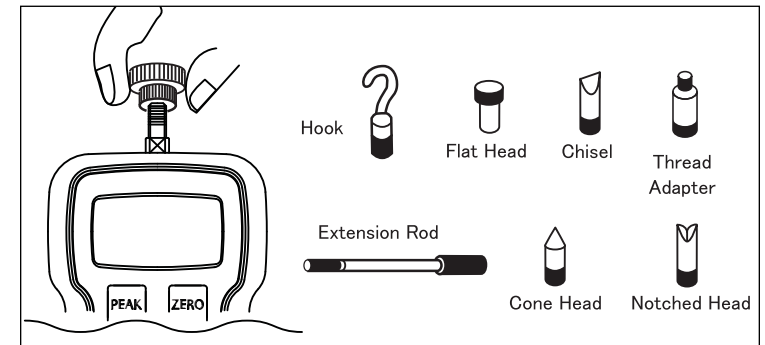

- Select the measurement adapter for your application and lightly hand tighten the accessory onto the sensor shaft.

Note: Overtightening an attachment with your hand or a tool can cause permanent damage to the gauge. Do not use a tool to tighten. Do not use a broken, bent or damaged attachment.

3.3 Using The Hanger

The hanger allows your FGV-XY to be hung from a fixture or winch. It is shaped specifically to fit onto gauge.

1. Remove the hanger bolt, place the square end of the hanger in the recessed area on the gauge and tighten the hanger bolt



Be sure that your fixture, stand or winch can support the gauge and applied load.

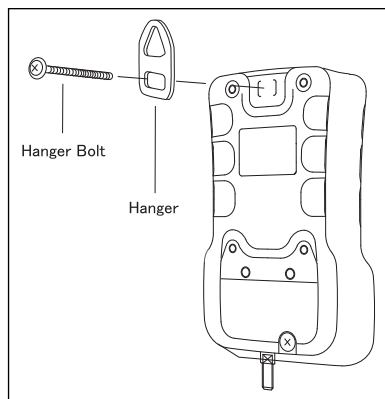

3.4 Tracking Function

The FGV-XY uses a load cell and strain gauge as its force sensor. The sensor is affected by environmental changes, such as temperature and humidity. The Tracking Function, which is active by default, helps to negate the effects of these changes.

NOTE: Tracking can cause errors when measuring very small forces. it is recommended that tracking be turned off in these situations.

To turn Tracking off:

1. Make sure that the power is turned off.
2. Hold down the **PEAK** and **UNIT** keys.
3. With the **PEAK** and **UNIT** keys still depressed, press **POWER** and hold until “oFF” appears on the display.



To turn Tracking back on:

1. Repeat steps 1–3 above.
2. Instead of “oFF”, “SEt” will appear on the display. Tracking is now activated.



12.3 RS-232C Communications Commands

Typical host to FGV-XY commands. “cr” means carriage return

Commands	Content	Response	Explanation of Response
AA cr	Tare	AA cr	Tare
AB cr	Cancel data transmission	AB cr	Cancel data transmission
AC cr	Switch to positive peak mode	AC cr	Switch to positive peak mode
AD cr	Switch to standard measuring mode	AD cr	Switch to standard measuring mode
AL cr	Switch to negative peak mode	AL cr	Switch to negative peak mode
AE cr	Clear peak values	AE cr	Clear peak values
AF cr	Switch unit to Kg, g	AF cr	Switch unit to Kg, g
AG cr	Switch unit to N	AG cr	Switch unit to N
AH cr	Switch unit to lb	AH cr	Switch unit to lb
AK cr	Switch unit to oz	AK cr	Switch unit to oz
BA cr	Request current measurement	BA cr NA xxxxxx cr	xxxxxx: Polarity, decimal point, 4 digit value
BB cr	Request continuous transmission of measurement data (10 times/second)	BB cr NA xxxxxx cr	
BB1 cr	Request continuous transmission of measurement data (20 times/second)	BB1 cr NA xxxxxx cr	
BB2 cr	Request continuous transmission of measurement data (50 times/second)	BB2 cr NA xxxxxx cr	
BB3 cr	Request continuous transmission of measurement data (100 times/second)	BB3 cr NA xxxxxx cr	
BC cr	Transmission request of model	BC cr NE xx cr	xx: 2-digit number indicating model 02: FGV-0.5, 03: FGV-1, 04: FGV-2, 05: FGV-5, 06: FGV-10, 07: FGV-20, 08: FGV-50, 09: FGV-100, 1A: FGV-200
BD cr	Transmission request of unit	BD cr NH x cr	x: one-digit number indicating unit 0: N, 1: kg, 2: g, 3: lb, 4: oz
BE cr	Transmission request of plus peak value	BE cr NB xxxxxx cr	xxxxxx: Polarity, decimal point, 4 digit value
BF cr	Transmission request of minus peak value	BF cr NC xxxxxx cr	
If the FGV-XY detects a communication error, the following error codes are sent.		OB cr	Format error (Command error)
		OF cr	Flaming error
		OH cr	Overrun error

12.4 Connection between FGV and Host

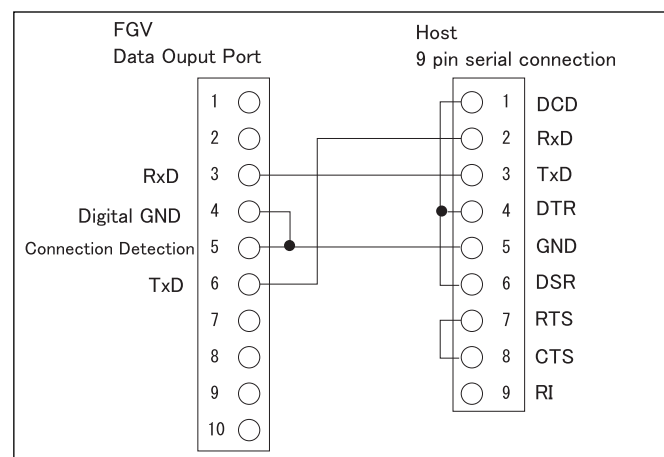

IMPORTANT: Without the connection between the Digital GND and pin 5, RS-232C communications will not work.

12.0 EXTERNAL DATA PORT

12.1 Pin Assignment

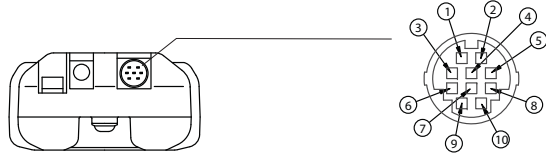

HR12-10RC-10SDL, by Hirose, is the output connector. We recommend HR12-10PCAE300 with 10 conductor shielded cable to make your own.

Please call your Shimpo dealer for information regarding optional cables and accessories.

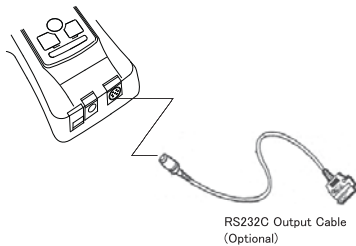

Pin Number	Signal Name
1	Analog +
2	Analog GND
3	RxD (RS-232C Received Data) Host → FGV
4	Digital GND
5	Connection Detection
6	TxD (RS-232C Transmitted Data) FGV → Host
7	Not Used*
8	Compression Overload / LO Comparator Output
9	Tension overload / HI Comparator Output
10	Common (for Pins 8 and 9)

*Always leave pin 7 unconnected.

12.2 RS-232C Output

The RS-232C data connection allows control from external devices and data transfers.

Interface

Baud rate*	2400, 4800, 9600, 19200 bps
Length of data bit	8 bit
Parity bit	None
Length of stop bit	1 bit
Flow control	None

*The baud rate is selectable through setting f04 (see section 4.4). The default factory setting is 2400 bps. consult your equipment manual or manufacturer for the correct baud rate. ASCII code, alpha numerics and carriage returns are used for RS-232C data transfer

4.0 FUNCTION MODES

To access and modify the function modes, follow this procedure:

1. Make sure that the gauge is powered off
2. Press and hold the **ZERO** key.
3. While continuing to press and hold the **ZERO** key, Press and release the **POWER** key.
4. Release **ZERO** after the display shows "f01."
5. Press **UNIT** to to change the setting within the function selected.

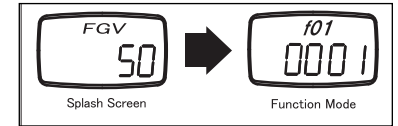

OR

6. Press **PEAK** to save the current setting and move to the next Function Mode

IMPORTANT NOTE: To scroll through the Function Modes, press the **PEAK** key repeatedly. The modes will appear in the order shown in the chart below.

OR

7. Press **ZERO** to save and exit the Function Modes.

Setting	Unit	Options	Default
Measurement Polarity	f01	-0.001 (minus), 0001 (plus)	0001
Display Update Time	f02	1, 2, 3, 5, 10, 20, (times/second)	3
Auto Power Off	f03	10 (10 minutes) oFF (always on)	10
RS232C Baud Rate	f04	2400, 4800, 9600, 19200 bps	2400
Response Time	f05	3, 20, 150 (msec)	3
Output Type	f06	ovEr, Hi-Lo	ovEr

4.1 Measurement Polarity (f01)

This function allows you to change whether compression is shown as a positive or negative force. once the compression display has been changed, the tension display will then read as the opposite of compression.

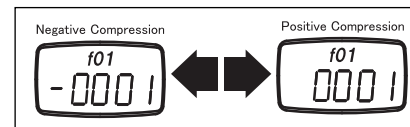

4.2 Display Update (f02)

This function allows you to change the rate at which the display is updated. The available times are 1, 2, 3, 5, 10 and 20 times a second.

Press **UNIT** to change the setting. Press **PEAK** to save and move to the next Function Mode. Press **ZERO** to save and return to standard measuring mode.

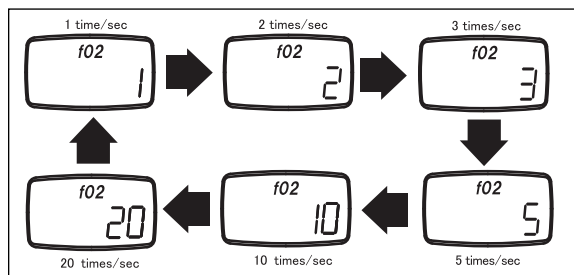

4.3 Auto Power Off (f03)

If the gauge is idle and there is no activity for 10 minutes, the unit automatically shuts off to conserve battery power. This option may be disabled, and is automatically disabled when connected to the AC adapter.

Press **UNIT** to change the setting. Press **PEAK** to save and move to the next Function Mode. Press **ZERO** to save and return to the standard measuring mode.

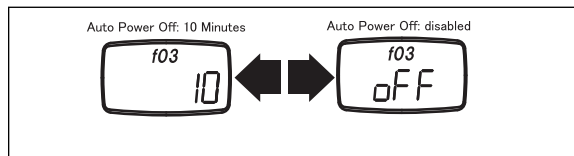

4.4 Baud Rate (f04)

This function allows you to change the RS-232C communications rate. The available baud rates are 2400, 4800, 9600 and 19200.

Press **UNIT** to change the setting. Press **PEAK** to save and move to the next Function Mode. Press **ZERO** to save and return to the standard measuring mode.

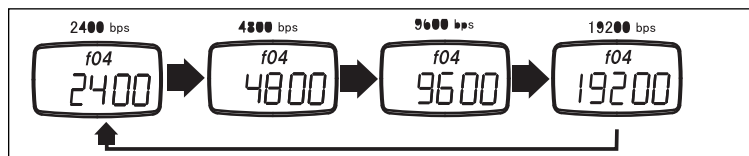

11.0 USB COMMUNICATIONS

The USB port allows you to connect your FGV-XY to your PC via the supplied USB cable. Our free software, TorriemonUSB, allows you to capture data directly into Excel.* (*Excel is a registered trademark of Microsoft Corporation.)

TorriemonUSB is available for free download at www.checkline.com/products/126333/fgv-xy_software_manual.zip.

11.1 Battery life and USB

Leaving the USB cable connected to the FGV-XY will drain the battery power at a faster rate. Only connect the gauge when taking data, or use the AC adapter for power when accessing data frequently.

10.0 CLEARING THE MEMORY

10.1 Clearing The Last Record

1. The last recorded memory block may be erased by pressing **ZERO** while viewing the last data point.
2. If **ZERO** is pressed while viewing any other data point, the display will show “Err” and will not delete anything.

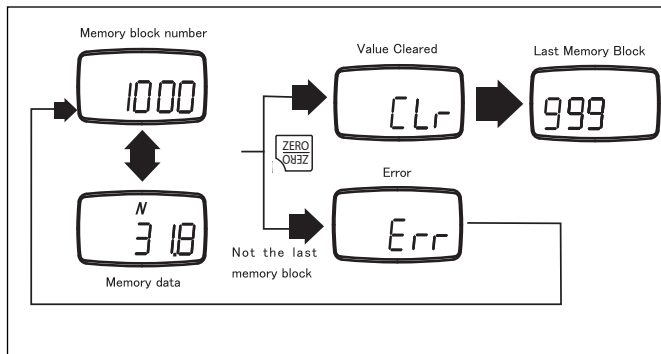

10.2 Clearing All Memory

1. When viewing the last memory point, press and hold **ZERO**.
2. The display will show “nonE”.
3. All memory has been cleared and the gauge returns to standard measuring mode.

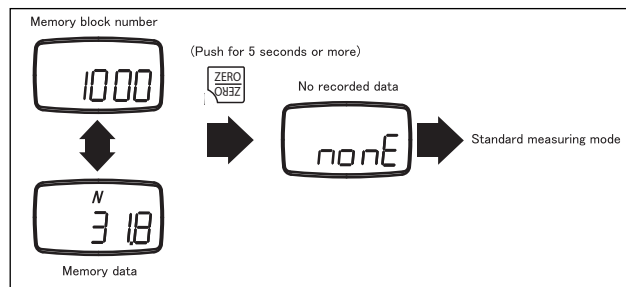

10.3 No Recorded Data

1. The display will show “nonE” is switching to memory mode when there are no recorded memory points.

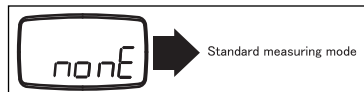

4.5 Response Time (f05)

The gauge's response time function smooths out the gauge's sampling and adjusts the sampling period accordingly. Response times are 3, 20 and 150 msec.

Press **UNIT** to change the setting. Press **PEAK** to save and move to the next Function Mode. Press **ZERO** to save and finish.

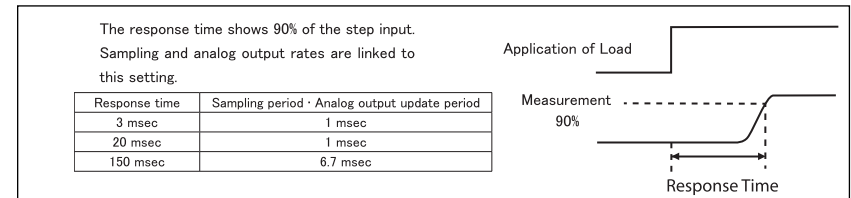
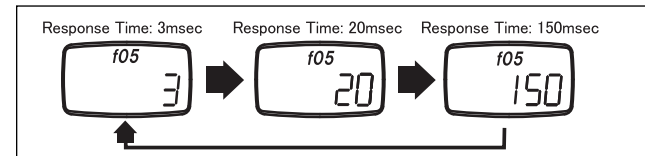

4.6 External Output (f06)

This function allows the user to change between Overload and Comparator type output. Press **UNIT** to change the setting.

Press **UNIT** to change the setting. Press **PEAK** to save and move to the next Function Mode. Press **ZERO** to save and return to the standard measuring mode.

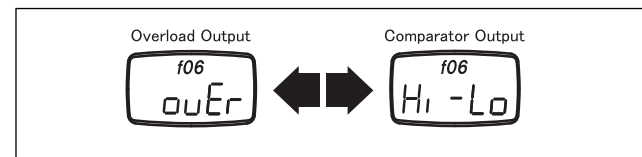

5.0 REVERSING THE DISPLAY

If you have mounted your FGV-XY upside down, or are holding the gauge upside down, the display may be reversed for readability

1. Turn **POWER** off.
2. Press and hold the **UNIT** key.
3. Press and release the **POWER** key while continuing to hold the **UNIT** key until the display screen appears in reverse.
4. Release the **UNIT** key.

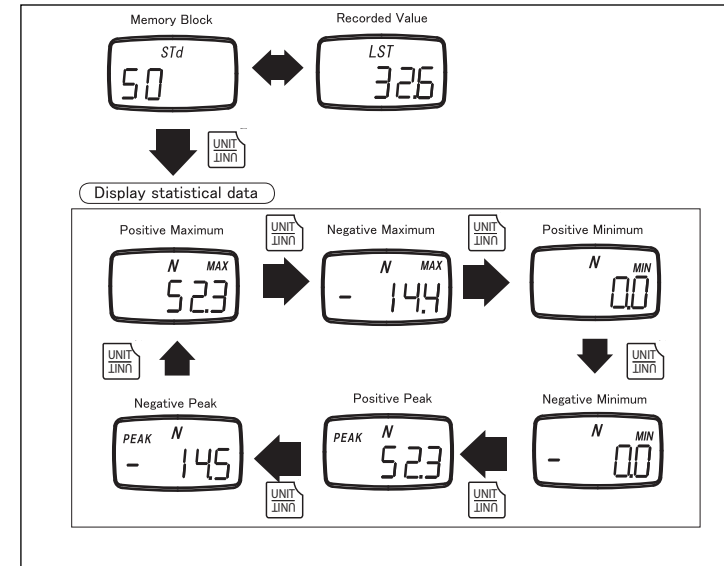
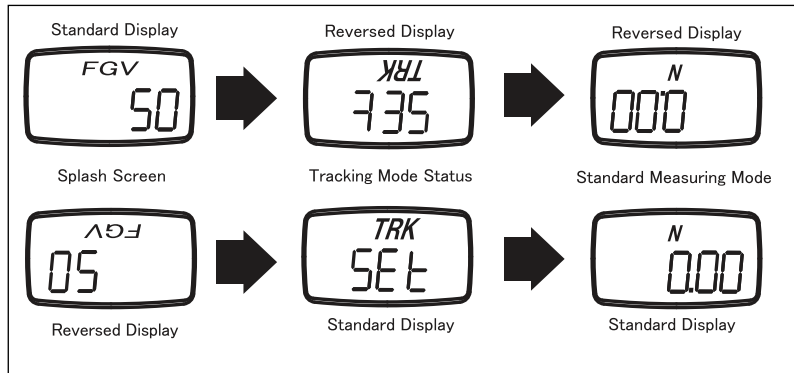

9.3 Standard Memory Mode

Accessing Memory Data

1. Turn **POWER** off.
2. Press **MEM** and hold, then press and release **POWER**. Release **MEM** when you see “**STd**” on the display. The unit will alternate between showing the data block number and the recorded measurement value of that block.
3. Press **MEM** to review the previous data block recorded.
4. Press **UNIT** to cycle through the available recorded statistics. In Standard mode, the available statistics are as follows: positive maximum value, negative maximum value, positive minimum value, negative minimum value.
4. Press **PEAK** to output the recorded data via RS232C. See section 12.

NOTE: Pressing **ZERO** deletes the current data block, but only if you have the last block selected.

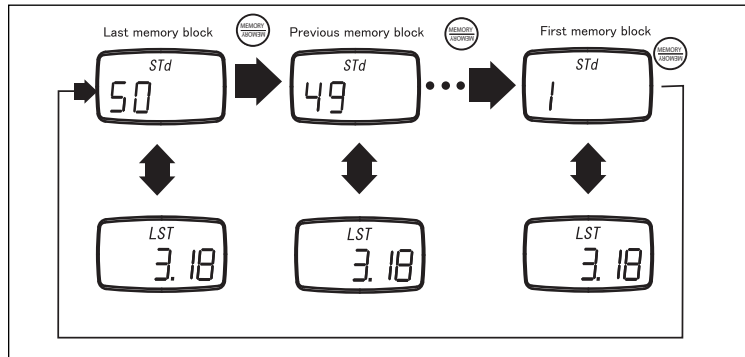

Statistics Data

1. When in memory mode, **UNIT** will cycle through the available statistics data.
2. Each press of **UNIT** will switch between the following items: positive maximum value, negative maximum value, positive minimum value, negative minimum value.
3. Press **MEM** to exit to the recorded measurement values.
4. Press the **PEAK** key to output the recorded memory via RS-232C. (See section 12).

6.0 MEASURING MODES

6.1 Standard Measuring Mode

This mode shows the current force applied, tension/compression, on the sensor shaft.

1. Press **POWER** to turn the FGV-XY on
2. Press **ZERO** to tare the gauge
3. If necessary, press and release **PEAK** until NO “**PEAK**” appears on the display.
4. The measurement displayed is the average of the measured samples* over the displays’s update time.

NOTE: The display update time is set to 3 times/second by default. This can be increase up to 20 times sec (see section 4..2)

* This is dependent on the Response Time function (f05), see section 4.5.



6.2 Peak Measuring Mode

The **PEAK** mode displays the greatest force in both the positive and negative direction. Sampling time is 1ms.*

1. Press **PEAK** to change from Standard measuring mode to Peak mode. Press **PEAK** again to enter positive or negative Peak mode
2. In the positive Peak mode, “**PEAK**” is displayed; while in the negative Peak mode, **PEAK** and “**-**” are displayed.

* This is dependent on the Response Time function (f05), see section 4.5..

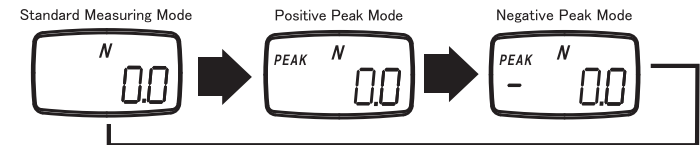

IMPORTANT!! While in either peak mode, **ZERO** will clear the current peak mode, but will not tare the gauge

6.3 Change the Displays Units

1. To change the measurement unit, press **UNIT**. The units of measure available with each gauge depends upon its capacity. See section 14.

6.4 Tare

NOTE: Press **ZERO** to reset the measured value. This will allow the gauge to ignore any force currently applied to the sensor shaft. The ignored, or tared, force is still counted with regards to the gauge's overload condition.

Overload will occur when the force applied to the sensor shaft exceeds the gauge's rated capacity by 20%. Stop measuring and remove the load immediately to avoid permanent damage to the gauge. Any measurements taken in the overload range are not accurate.

1. Tare is automatically performed when the gauge is first powered on.

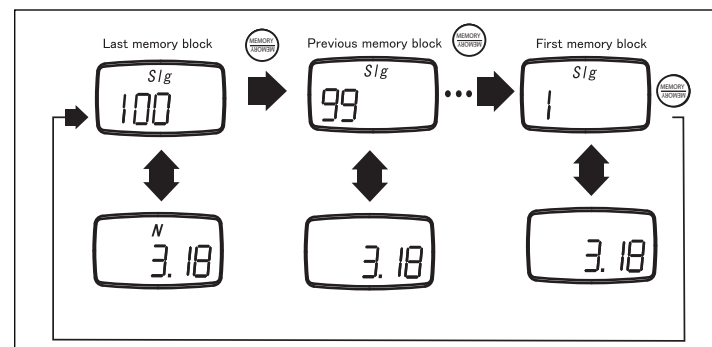

Statistics Data

1. When in memory mode, **UNIT** will cycle through the available statistics data.
2. Each press of **UNIT** will switch between the following items: positive maximum value, negative maximum value, positive minimum value, negative minimum value, average value, standard deviation.
3. Press **MEM** to exit to the recorded measurement values.
4. Press **PEAK** key to output the recorded memory via RS-232C. (See section 12).

NOTE: Pressing MEM exits statistics mode and returns to memory blocks.

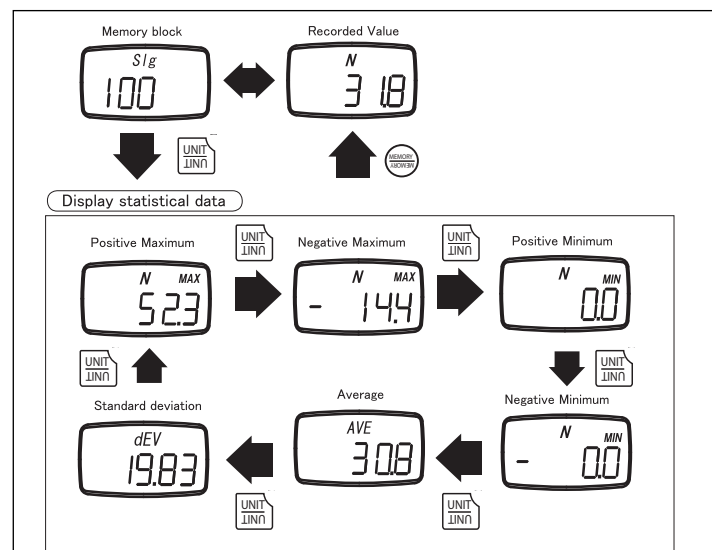

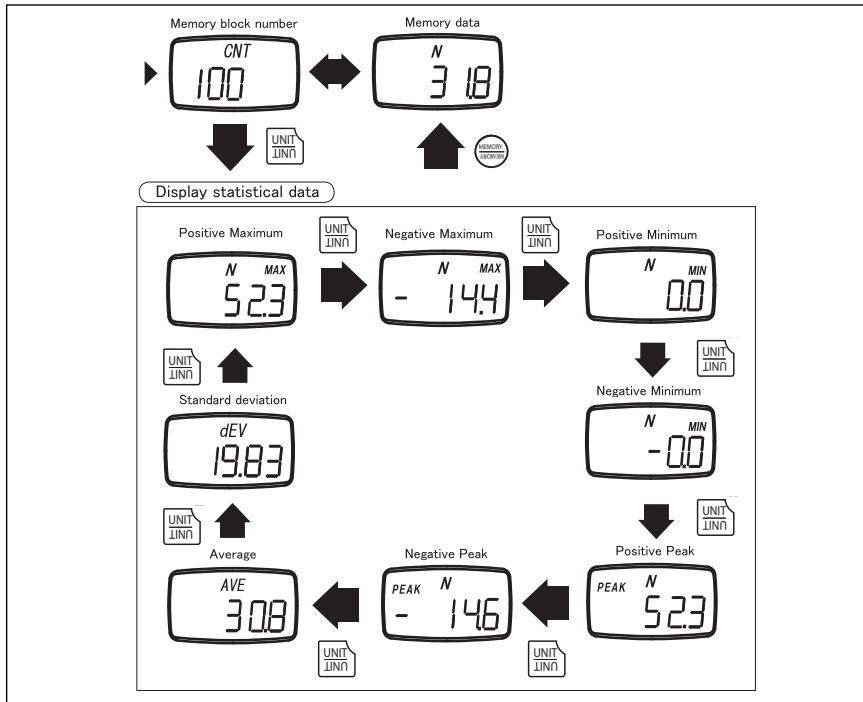

9.2 Single Memory Mode

Accessing Memory Data

1. Turn **POWER** off.
2. Press **MEM** and hold, then press and release **POWER**.
3. Release **MEM** when you see “**Sig**” on the display. The unit will alternate between showing the data block number and the recorded measurement value of that block.
4. Press **MEM** to review the previous data block recorded.
5. Press **UNIT** to cycle through the available recorded statistics. In Single mode, the available statistics are as follows: positive maximum value, negative maximum value, positive minimum value, negative minimum value, average value, standard deviation.
6. Press **PEAK** to output the recorded data via RS232C. See section 12.

NOTE: Pressing **ZERO** deletes the current data block, but only if you have the last block selected.

7.0 COMPARATOR

The Comparator function allows you to create conditions for Go/No Go testing. A high (HI) and low (LO) force limit may be set so that the FGV-XY’s display will show when a measurement is not within the HI and LO settings. In addition, the output port will respond relative to the display. See section 7.4 regarding the comparator output.

NOTE: The FGV-XY must be in Comparator mode, and not Overload mode to use the following settings. See section 4.5.6 regarding the output mode.

7.1 Memory Setting Mode

1. Turn **POWER** off, press **PEAK** and hold.
2. Press **POWER** and hold until “**HI**” appears on display, then release.

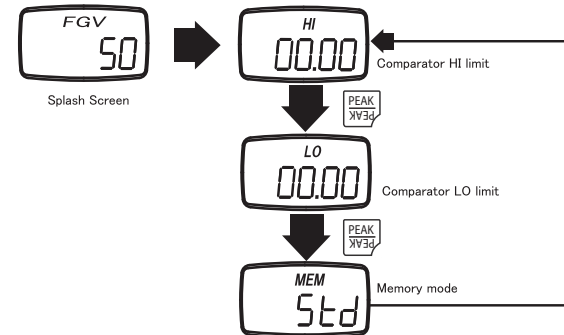

Setting	Display	Content	Default Factory Setting
Comparator HI limit	HI	Value for HI limit*	0
Comparator LO limit	LO	Value for LO limit*	0
Memory Mode	MEM	Memory Mode (Standard, Single, Continuous)	Std

* When HI and LO are set to 00.00 the Comparator function is disabled.

7.2 Setting the HI Limits

1. Press **UNIT** to select the **HI** Setting. The digits will start flashing
2. Press **UNIT** again to change the polarity.
3. Choose the digit to change by pressing **ZERO**.
4. Press **UNIT** to increase the selected digit to the desired value.
5. Repeat steps 3 and 4 until the desired value and polarity are correct.
6. Press **PEAK**. This saves the **HI** limit and displays the **LO** limit.
7. Press **MEM** if you are finished.

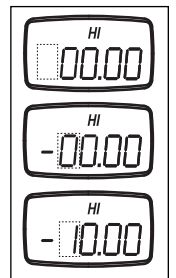

NOTE: The values entered for the HI and LO settings are displayed in the measurement units last used in Standard Mode.

NOTE: The absolute value of the HI limit can never be lower than the absolute value of the LO limit.



The Comparator function's limits can be set outside of the FGV-XY's working range. This may cause unpredictable results, and is not recommended

7.3 Setting the LO Limit

1. Press **UNIT** to select the **HI** Setting. The digits will start flashing.
2. Press **PEAK**. This saves the HI limit and displays the **LO** limit.
3. Press **UNIT** again to change the polarity.
4. Choose the digit to change by pressing **ZERO**.
5. Press **UNIT** to increase the selected digit to the desired value.
6. Repeat steps 3 and 4 until the desired value and polarity are correct
7. Press **MEM** if you are finished with the Comparator and Memory settings.



NOTE: The absolute value of the LO limit can never be higher than the absolute value of the HI limit.

7.4 Comparator Display

The following symbols are shown when the Comparator function is active:

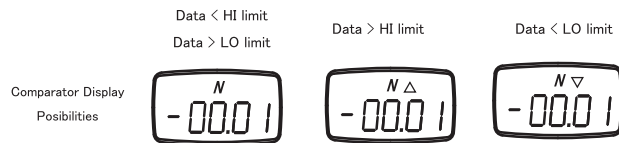

NOTE: In order for the Comparator function to display, the Comparator output option must be set in function f06. See section 4.6 regarding this setting.

7.5 Comparator Output

The Comparator function also allows control of an alarm or automated process through its data output port. When the measured value is greater than the HI limit, the corresponding photo-couple is triggered. When the measured value is lower than the LO limit, the corresponding photo-couple is triggered.

NOTE: In order for the Comparator function to display, the Comparator output option must be set in function f06. See section 4.6 regarding this setting.

NOTE: For connection and circuit information pertaining to the Comparator output see section 12.6.

9.0 REVIEWING MEMORY DATA

9.1 Continuous Mode Memory

Accessing Memory Data

1. Turn the **POWER** off.
2. Press **MEM** and hold, then press and release **POWER**. Release **MEM** when you see "CNT" on the display. The unit will alternate between showing the data block number and the recorded measurement value of that block.
3. Press **MEM** to review the previous data block recorded.
4. Press **UNIT** to cycle through the available recorded statistics. In Continuous mode the available statistics are as follows: positive maximum value, negative maximum value, positive minimum value, negative minimum value, positive peak value, negative peak value, average value, standard deviation
5. Press **PEAK** to output the recorded data via RS232C. See section 12.

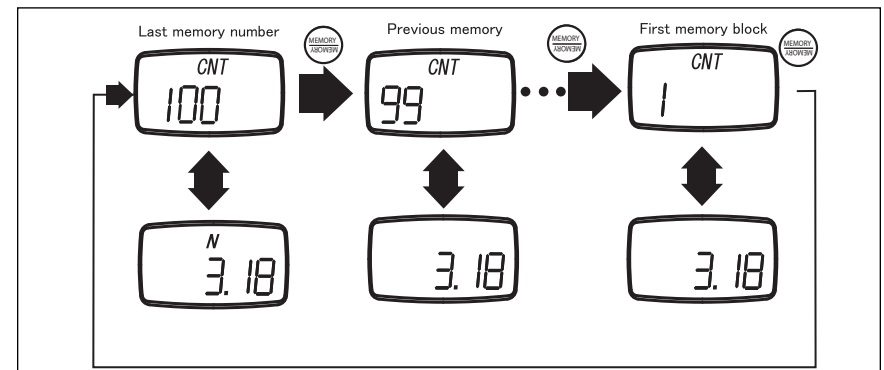

NOTE: Pressing **ZERO** deletes the current data block, but only if you have the last block selected

Statistics Data

1. When in memory mode, **UNIT** will cycle through the available statistics data.
2. Each press of **UNIT** will switch between the following items: positive maximum value, negative maximum value, positive minimum value, negative minimum value, positive peak value, negative peak value, average value, standard deviation.
3. Press **MEM** to exit to the recorded measurement values.
4. Press **PEAK** key to output the recorded memory via RS-232C. (See section 12).

NOTE: Pressing **MEM** exits statistics mode and returns to memory blocks.

Single Mode:

1. In the Single Measurement Mode, Press **MEM** to start the recording. The letter **M** will appear and start blinking. Press **M** to stop recording.
2. If 1000 points of data are recorded, the display will show **FULL** and return to standard measurement mode.

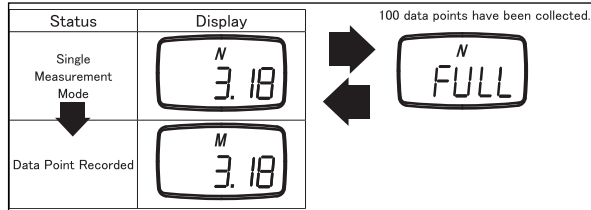

Standard Mode:

1. In the Standard Measurement Mode, Press **MEM** to start the recording. The letter **M** will appear and start blinking. Press **M** to stop recording.
2. If 1000 points of data are recorded, the display will show **FULL** and return to standard measurement mode.

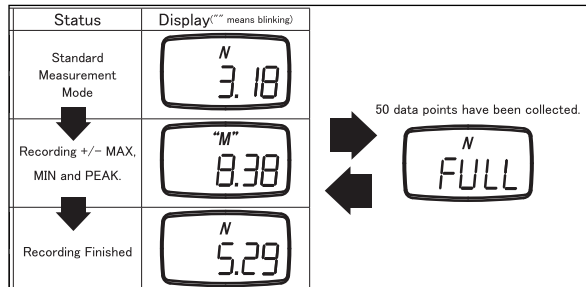

8.0 SETTING MEMORY MODE / RECORDING DATA

The FGV-XY has three memory modes:

Continuous Memory: Allows the recording of up to 1000 data points. the recording starts when you push MEM, and stops when you push MEM. In addition, the following statistics, gathered between that start and stop, are recorded; positive maximum value, negative maximum value, positive minimum value, negative minimum value, positive peak value, negative peak value, average value, standard deviation.

Single Memory: Allows the recording of up to 100 data points. every time MEM is pressed, the value shown on the display is memorized. if the unit is in Standard mode then the current measured value is recorded. In Peak mode, the unit records the displayed peak value, in addition, the following statistics are recorded; positive maximum value, negative maximum value, positive minimum value, negative minimum value.

Standard Memory: Allows the recording of up to 50 data points. The recording process is similar to Continuous mode. MEM starts the recording and stops the recording. The measured value when MEM is pushed the second time, is recorded as a point. the following statistics, gathered between the start and stop, are recorded: positive maximum value, negative maximum value, positive minimum value, negative minimum value.

Memory Terms Defined

Measurement Value: The current displayed value in Standard Mode.

Positive Maximum Value (+Max): Maximum value in the positive direction.

Negative Maximum Value (-Max): Maximum value in the negative direction.

Positive Minimum Value (+Min): Minimum value in the positive direction.

Negative Minimum Value (-Min) Minimum value in the negative direction.

Average Value (AVE): Average of the recorded measurement values

Standard Deviation (DEV): Standard deviation of the recorded measurement values

Positive Peak Value: Largest value in the positive direction.
(This value is sampled at 1000 times per second.)

Negative Peak Value: Largest value in the negative direction.
(This value is sampled at 1000 times per second.)

Last Measurement Value (LST): The last measurement value displayed at the corresponding time.

Example of +MAX, -MAX, +MIN, -MIN (Continuous memory mode)

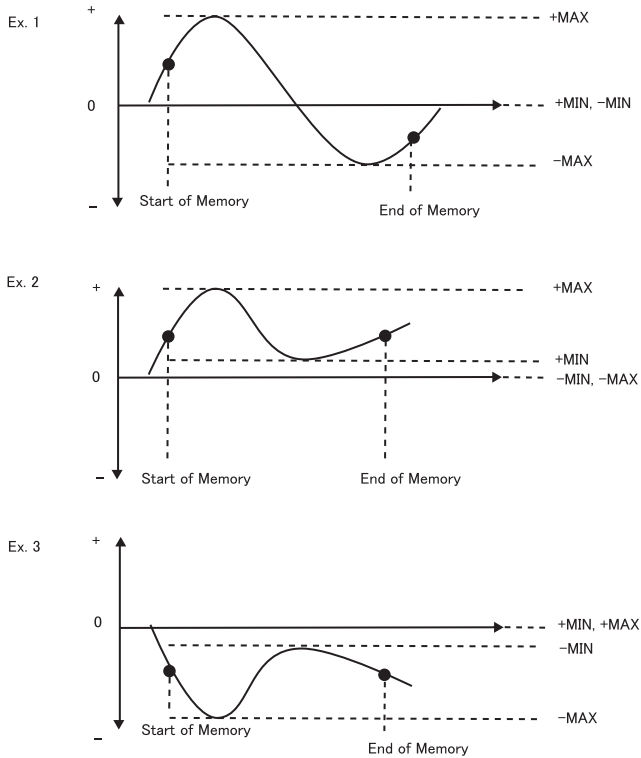

8.1 Setting the Memory Mode

1. Turn the **POWER** off.
2. Press **PEAK** and hold, then press and release **POWER**.
The display will show the HI Comparator limit
3. Press **PEAK** twice to display the current memory mode.
4. Press **UNIT** to cycle the Memory mode
5. Press **MEM** to save and exit.

The following items are found in the Comparator/Memory mode settings.

Setting	Display	Content	Default Factory Setting
Comparator HI limit	HI	Current HI limit	0
Comparator LO limit	LO	Current LO limit	0
Memory Mode	MEM	Current Memory Mode	Std

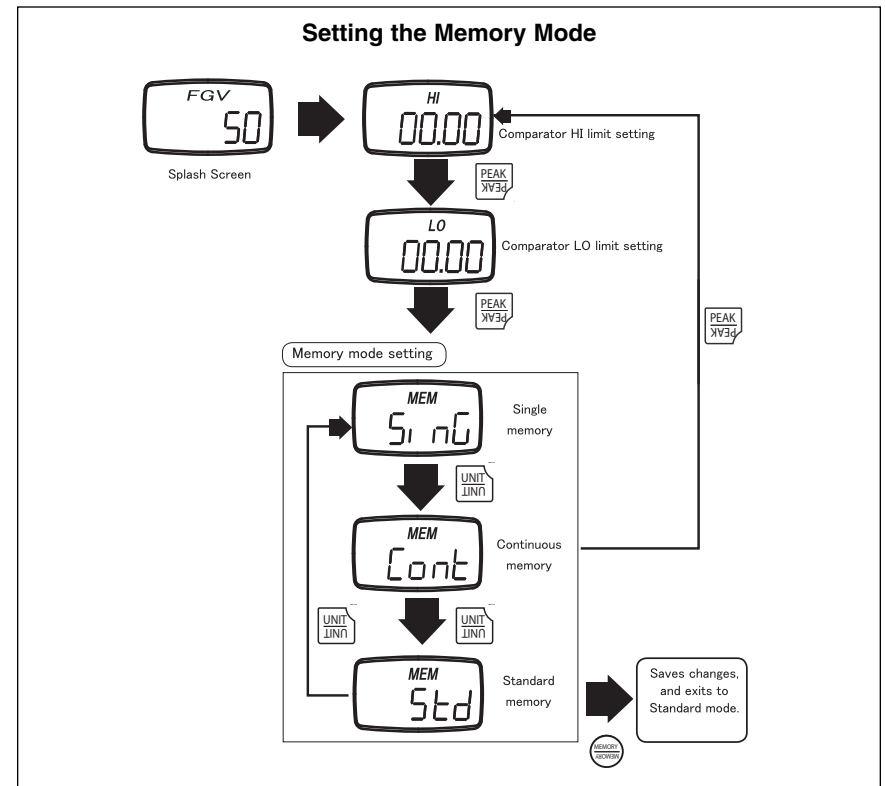

8.2 Recording Memory Data

The following procedures explain how to activate memory recording for each memory mode

Continuous Mode:

1. In the Continuous Measurement Mode, Press **MEM** to start recording.
The letter **M** will appear and start blinking. Press **M** to stop recording.
2. If 1000 points of data are recorded, the display will show **FULL** and return to standard measurement mode.

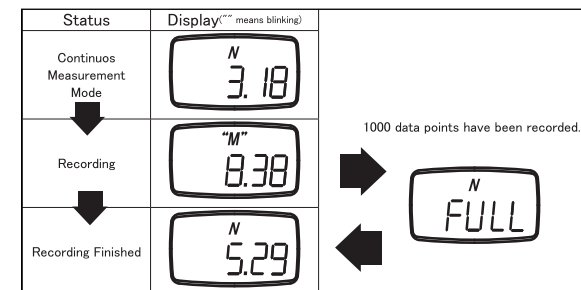

Model FGV-XY

DIGITAL FORCE GAUGE



Operating Instructions

Albuquerque Industrial
69-10 108th Street # 2-0
Forest Hills, NY 11375 U.S.A.

www.abqindustrial.net
e-mail: info@abqindustrial.net
Toll Free: +1 (888) 275-5772
Tel: +1 (718) 846-6458
Fax: +1 (718) 846-6459