

# Force Test Stands Series **ES**

---

MODELS ESM & ES30

## User's Guide



Albuquerque Industrial  
69-10 108th Street # 2-0  
Forest Hills, NY 11375 U.S.A.

[www.abqindustrial.net](http://www.abqindustrial.net)  
e-mail: [info@abqindustrial.net](mailto:info@abqindustrial.net)  
Toll Free: +1 (888) 275-5772  
Tel: +1 (718) 846-6458  
Fax: +1 (718) 846-6459

**Thanks!**

Thank you for purchasing a Mark-10 Series ES Force Measurement Test Stand. We are confident that you will get many years of great service from this product.

Mark-10 test stands are ruggedly built for many years of service in laboratory and industrial environments.

This User's Guide provides unpacking, setup, and operator instructions for the Model ES30 and Model ESM Force Measurement Test Stands. Dimensions and specifications are also provided. For additional information or answers to your questions, our technical support and engineering teams are eager to help you.

Thank you again for your purchase and happy testing!

**TABLE OF CONTENTS**

**LIST OF INCLUDED ITEMS**.....2

**UNPACKING AND SETTING UP** .....2

**MODEL ESM** .....3

    Safety Tips.....3

    Setup .....3

    Operation.....4

    Specifications .....5

    Dimensions.....6

**MODEL ES30** .....7

    Operation.....7

    Dimensions.....8

    Specifications .....8

**OTHER TEST STANDS BY MARK-10**.....9

**FORCE GAUGES BY MARK-10** .....10

**WARRANTY** .....10

**FORCE GAUGES BY MARK-10**  
*Capacities from 0.25 lb (1 N) to 500 lb (2500 N)*



**Force Gauges Series EG**

- Reversible aluminum housing for hand-held use or stand mounting
- Three units of measurement: lb, kg, N
- Programmable initial status of units and mode of operation
- Automatic peak memory
- Push-button calibration
- Battery or AC operation with programmable automatic shutoff
- Permanent configuration memory
- Optional RS-232, Mitutoyo and analog outputs



**Force Gauges Series BG** (in addition to EG features)

- RS-232, Mitutoyo and analog outputs
- GCL – Gauge Control Language for full control of all functions
- Automatic timed output on RS-232
- Dual set points with outputs
- General purpose I/O for external device control
- Programmable analog and digital filters
- Averaging mode for obtaining average force readings over time



**Force Gauges Series MG**

- Low cost and small size
- Aluminum housing is reversible for hand-held use or test stand mounting
- Peak memory for tensile and compressive loads
- Selectable units of measurement programmable auto shutoff
- Push-button calibration
- IPM - Intelligent Power Management system for reliable operation

**WARRANTY**

Mark-10 Corporation expressly warrants to its buyer for three (3) years from the date of delivery that the goods sold are free from defects in workmanship and materials. Mark-10 Corporation will, at its option, repair or replace or refund the purchase price of goods found to be defective. This remedy shall be the buyer's sole and exclusive remedy. Any modification, abuse, exposure to corrosive environment or use other than intended will void this warranty. This warranty is in lieu of all other warranties, including implied warranties of merchantability and fitness for an intended purpose. In no event shall Mark-10 Corporation be liable for any incidental and consequential damages in connection with goods sold or any part thereof.

## OTHER TEST STANDS BY MARK-10

*Manual and motorized, up to 1,000 lb and 100 lbin*



**TSAH**  
Manual, Force  
Lever  
750 lb

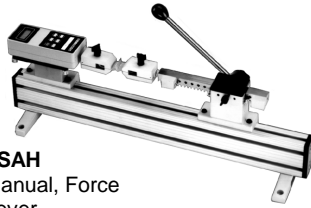

**TSB**  
Manual, Force  
Lever  
100 lb



**TSF**  
Manual, Force  
Hand wheel  
1,000 lb

**TSTM**  
Motorized, Torque  
100 lbin

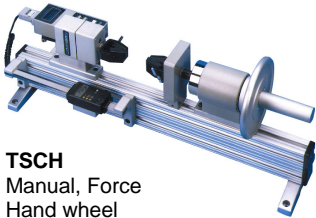

**TSCH**  
Manual, Force  
Hand wheel  
1,000 lb



**TSA**  
Manual, Force  
Lever  
750 lb



**ES10**  
Manual, Force  
Lever  
100 lb



**ES20**  
Manual, Force  
Hand wheel  
100 lb

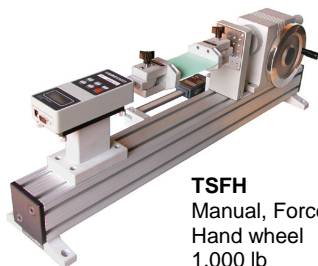

**TSFH**  
Manual, Force  
Hand wheel  
1,000 lb



**ES30**  
Manual, Force  
Hand wheel  
200 lb



**TSC**  
Manual, Force  
Hand wheel  
1,000 lb

## LIST OF INCLUDED ITEMS

Quantity	Item
1	Force measurement test stand
1	Remote console (ESM, only)
1	Power cord (ESM, only)
1	User's guide (this booklet)
4	Thumb screws for gauge mounting
1	Mounting hole drill template
1	Accessories set (small hook, medium hook, 2" diameter compression plate, 2" extension rod, and #10-32 adapter)

### Optional items

Part No.	Description
ESM001	Digital travel display kit
ESM002	Limit switch kit (available for ESM, only)

Carefully unpack the test stand and inspect for any damage. Check the contents to ensure that you have received a test stand complete with all accessories – see the above list of included items.

# ESM

## SAFETY TIPS

- Wear eye and face protection when testing. Although the ESM has relatively slow moving mechanisms, be aware of the dangers posed by potential energies that can accumulate in the sample during testing.
- Keep away from the moving parts of the test stand.
- Never operate the test stand if there is any visible damage to the power cord or the control unit. The ESM is powered by 110/220 volts that are present in both the power cord and the control unit. Any contact with this high voltage can cause serious injury or even death.
- Ensure that the control unit be kept away from water or any other electrically conductive liquids at all times.
- Make sure the electrical outlet powering the test stand has local earth ground (3-hole outlet).
- If it is necessary to remove the cover of the control unit or motor drive, always disconnect power before doing so. Use Mark-10 replacement parts, only, if any repairs are needed.

## SETUP

Place the stand on a clean, flat and level work area that meets the criteria outlined in the work area safety instructions. For accurate readings, the area should be free of vibrations.

If desired, the stand can be mounted to the work area with two 5/16 screws. Included is a mounting hole drill template for quick setup. Before the stand can be mounted, the belt cover surrounding the fine adjustment knob on the right hand side of the stand has to be removed. Using a flat screwdriver, loosen the four captive screws and slide off the cover.

After the two 5/16 screws holding the stand are tight, place the belt cover back into place. While making sure that there is no contact with the fine adjustment knob, tighten the screws in the four corners.

# ES30

## DIMENSIONS

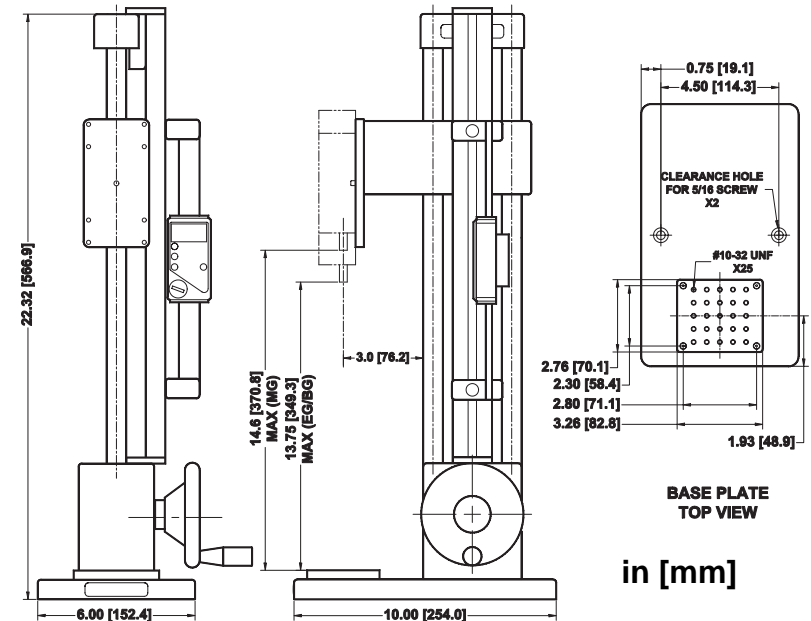

## SPECIFICATIONS

Load capacity	200 lbs. (1000 N)
Maximum travel	13" (228.6 mm)
Loading method	Hand wheel
Travel rate	0.05"/rev. (1.27 mm)
Weight (test stand, only)	17 lbs (7.7 kg)

## ES30

### OPERATION

Place the stand on a clean, flat, and level surface. It is recommended that the stand be mounted to the surface with two 5/16 screws. Use the mounting hole drill template for quick setup. Install a force gauge onto the gauge plate with four thumb screws. All Mark-10 force gauges (except the Series CG) mount directly to the stand without adapters.

Install the necessary attachments and make sure they are secure, safe to operate, and set up properly for your sample. Then zero out the force gauge and turn the hand wheel clockwise for compression or counter-clockwise for tension.

The base is removable so that the stand may be used as a component of a larger testing system. Proper care should be taken during installation to avoid injury.

To maintain smooth functioning of the stand, avoid overloads.

#### **Optional Equipment**

##### *Digital Travel Display Kit*

This position indicator covers 6" of travel per setting with a 5 digit display (0.0005" resolution) and a computer interface for automated data collection. It may be easily installed by the user.

##### *Motor Drive Kit*

The motor drive kit converts an ES30 manual test stand into an ESM motorized test stand. The kit consists of a motor block that replaces the hand wheel, a remote console and an optional limit switch kit. The speed is user selectable from 0.5 to 13 in/min [13 to 330 mm/min] and it is load independent. The system is overload regulated to 150% of full capacity.

## ESM

With the base removed, the ESM can be easily integrated into large systems such as production lines. In general, the stand can be mounted on any angle (upside down, for example), although extra care should be taken during installation and operation.

After the stand is in a stable and secure position, install a force gauge with four thumb screws (provided). All Mark-10 gauges (except the Series CG) mount directly without adapters.

Plug the remote console cable into the 9-pin male connector located above the motor in the rear of the stand.

Plug the power cord into the remote console and the other side into a wall outlet.

Turn on the power with the switch located on the remote console by the power cord.

The test stand is now ready for operation.

### OPERATION

Using the provided attachments, set up your sample, zero out the force gauge and, if applicable, connect it to a computer or printer. When the gauge and sample are ready for testing, use the remote console to operate the test stand. For fine adjustment or otherwise manual testing, turn the knob on the right hand side of the stand clockwise for compression, counter-clockwise for tension.

#### **Optional Equipment**

##### *Limit Switches*

Adjust the switches' vertical positions by loosening and re-tightening the wing screws. A limit condition is indicated by an amber light on the front surface of each sensor.

**Upper limit switch** – while a limit condition exists, the slider will not move up

**Lower limit switch** – while a limit condition exists, the slider will not move down

# ESM

## Using the Control Unit

### ▲ UP

Press and hold for tension, release button to stop motion. Located on the face of the Control Unit.

### ▼ DOWN

Press and hold for compression, release button to stop motion. Located on the face of the Control Unit.

### SPEED CONTROL DIAL

Adjust speed by turning the dial 0.5 – 13 in/min [13 – 330 mm/min]. Located on the face of the Control Unit.

### POWER SWITCH

Use this switch, in the left rear of the Control Unit, to turn on and turn off power to the test stand. Power is indicated by an amber light on the face of the Control Unit

### POWER PLUG RECEPTACLE

Located in the left rear of the Control Unit. Plug the power cord in here.

### CONTROL CABLE

Plug this cable into the lower male connector on the test stand, adjacent to the motor.

## SPECIFICATIONS

Load capacity	200 lbs [1000 N]
Speed range	0.5-13 in/min [13-330 mm/min]
Maximum travel	13.0 in [228.6 mm]
Maximum travel w/options	11.75 in [298.45 mm]
Speed variation with load	±0% (Stepper motor driven)
Speed accuracy	±5% of setting
Overload protection	Max. 150% of full capacity
Power	Universal input 80-240 VAC, 50/60 Hz
Fuse type	1.2 A, 250V, 3AG SLO BLO
Weight (test stand, only)	20 lbs [9.1 kg]
Control unit weight	2.7 lbs [1.2 kg]

# ESM

## DIMENSIONS

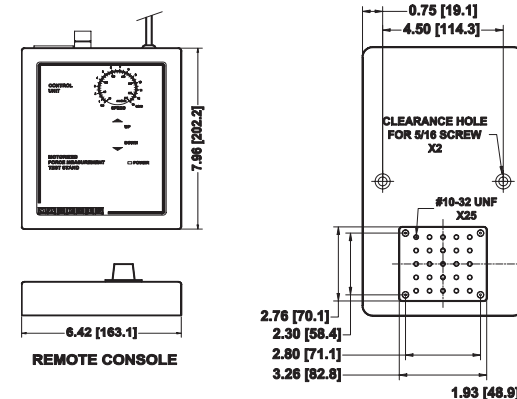
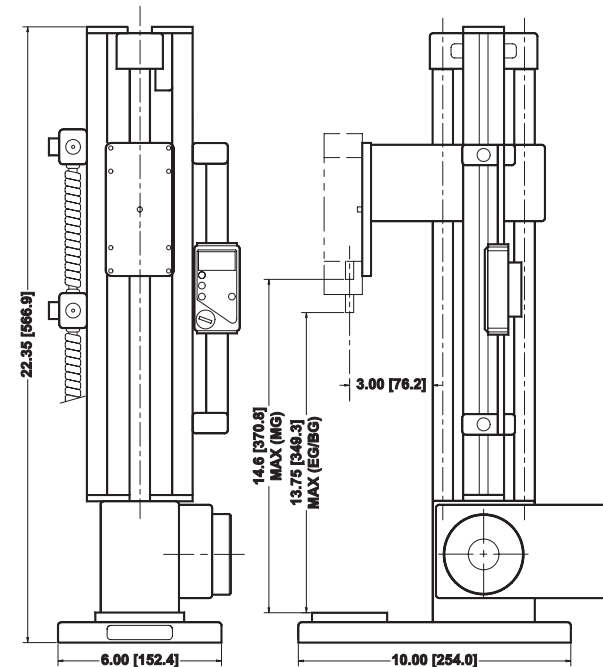

in [mm]