

# DIMENSIONS

In [mm]

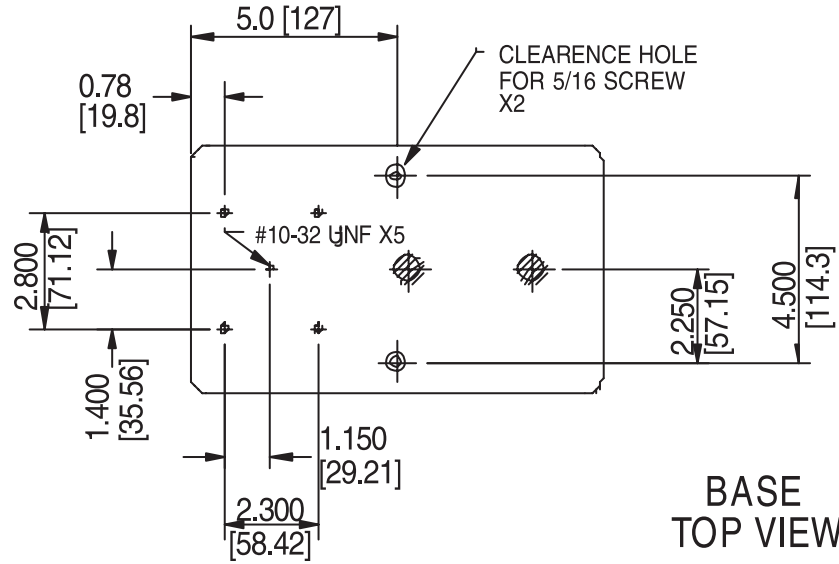

BASE  
TOP VIEW

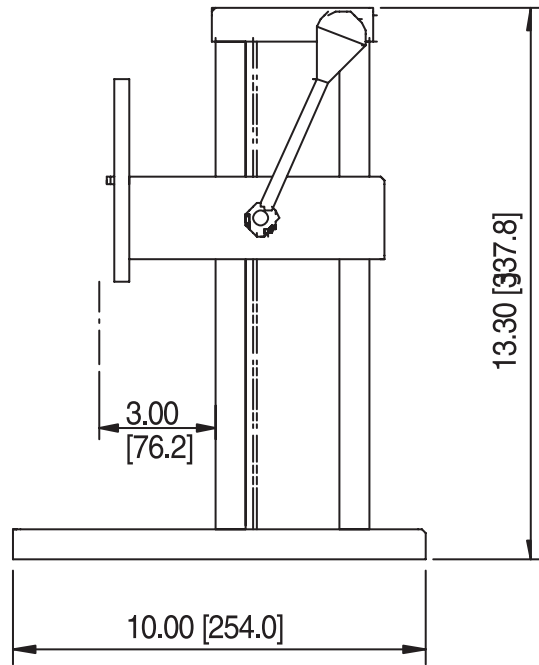
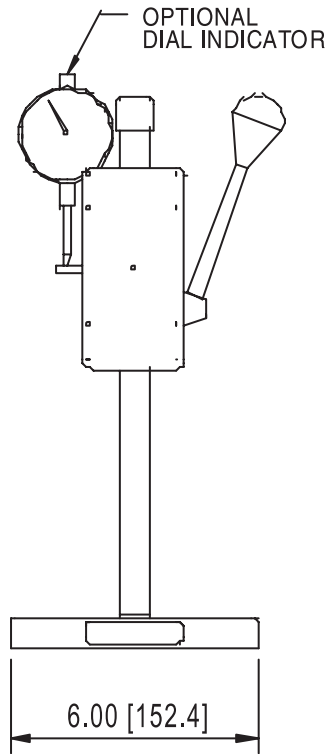

ES10