Digital Durometer

Model DD-100



Operating Instructions

Table of Contents

1.0 Introduction	2
1.1 Unpacking		
1.2 Complete Kit		
2.0 Power	3
2.1 Battery Installation		
2.2 Using the AC Adapter		
3.0 Operating Instructions	4
3.1 ON/OFF		
3.2 AUTO OFF		
3.3 HOLD		
3.4 TOLERANCING		
3.5 CLEAR		
3.6 TOTAL RESET		
3.7 FEATURE LOCK		
4.0 Specifications	5
4.1 Conforms to International Standards	
4.2 Dimensional Drawings		
5.0 Calibration & Repair	7
6.0 Warranty	8

1.0 Introduction

The new Check-Line DD-100 digital durometer is the ideal choice for a wide range of Shore hardness measuring applications. Seven scales are available: A, B, C, D, DO, O, OO.

The DD-100 conforms to:

- ASTM D-2240
- DIN 53505
- ISO 868
- ISO 7619

1.1 Unpacking

Unpack the durometer and inspect it for any shipping damage. Notices of defect must be filed immediately, in writing, at the latest within 10 days on receipt of the goods.

1.2 Complete Kit

The DD-100 is supplied as a complete kit including the durometer, instruction manual and NIST-traceable calibration certificate all in a foam-fitted metal carrying case.



2.0 Power

2.1 Battery Installation

The DD-100 digital durometer use two internal batteries or an AC adapter.

1. Using a narrow screwdriver, gently pry under the tab on the left side of the plastic bezel and slide the battery tray as you turn the gauge face down.
2. Insert two batteries, “+” side up, into tray cavities, then slide the tray into its bezel slot, taking care that the batteries stay in proper position.

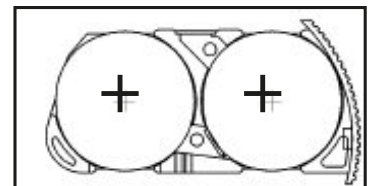
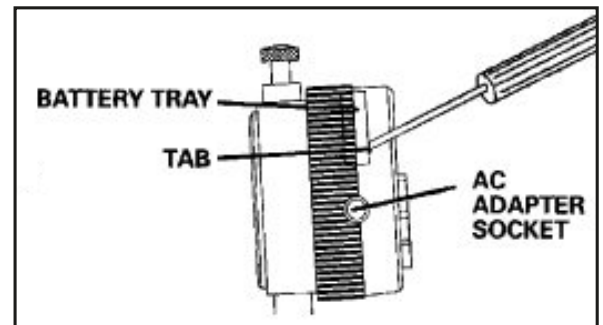

NOTE: It is highly recommended that the batteries be removed from the gauge if it will not be used, or will be powered by the adapter for an extended period of time. This is to prevent damage to the gauge from battery leakage or corrosion.

2.2 AC Adapter

A 9V AC adapter can also be used to power the gauge for continuous operation. These adapters provide 9V DC \pm 10% to the gauge, with current limited to 30mA. Connecting the AC adapter disconnects the internal batteries (if installed).

NOTE: Do not attempt to attach the AC adapter when the gauge is already on, this could result in erroneous readings on an error condition

3.0 Operating Instructions

To operate the gauge, press the foot of the gauge firmly against the specimen, but not so firmly as to imbed the foot into the surface. This will yield the maximum durometer reading. If, during use, the display “freezes” on a number, simply remove the dust cover on top of the gauge and depress the screw with a pen or pencil, then press **ON/CLR**. This resets the gauge—no further calibration is necessary.



3.1 ON/OFF

1. To Turn Gauge On Press **ON/CLR** and release when **CLR** appears.
2. To Turn Gauge Off Press and release **OFF/MODE**.

3.2 AUTO OFF

To Activate/Deactivate Auto Off

1. Press and hold **MOVE 2ND** until **2ND** appears on the bottom of the display and then release.
2. Press and release **OFF/MODE** within 3 seconds.

NOTE: An hour glass will appear on left side of display if Auto Off feature is active

3.3 HOLD

To Activate/Deactivate Hold

1. Press and release **HOLD** until **MAX** appears in the top of the display.
2. Press and hold **HOLD** until **MAX** disappears.

3.4 TOLERANCING

To Set Tolerance Numbers

1. Press and hold **TOL** until cursor moves under **HIGH**.
2. Press and release **CHNG** and **MOVE 2ND** simultaneously.

NOTE: SET appears on bottom of display.

3. Press and release **MOVE 2ND** until the digit to be set is blinking.
4. Press and release **CHNG** to increment the blinking digit.
5. Repeat steps 2 and 3 until desired number is entered.
6. Press and release **CHNG** and **MOVE 2ND** simultaneously

NOTE: After step 5 is complete, the cursor will automatically move to LOW. Repeat steps 1 through 5 to set the low tolerances.

To Activate/Deactivate Tolerances

1. Press and release **TOL**.

NOTE: When the tolerance feature is on, any reading out of tolerance will result in a flashing display.

3.5 CLEAR

To Clear Display To Zero

1. Press and release **ON/CLR**.

3.6 TOTAL RESET

To Clear All Settings And Return To Factory Set Defaults

1. Press and hold **MOVE 2ND** until **2ND** appears on bottom of display and then release.
2. Press and release **ON/CLR** within 3 seconds.
3. Press and release **CHNG** within 3 seconds.

NOTE: Total reset cannot be accomplished if lock feature is on.

3.7 FEATURE LOCK

To Activate/Deactivate Lock Feature

1. Press and hold **MOVE 2ND** until **2ND** appears on bottom of display and then release.
2. Press and release **ON/CLR** within 3 seconds.
3. Press and release **TOL** within 3 seconds.

NOTE: A key will appear on the bottom left side of display when features are locked.

4.0 Specifications

Resolution	0.1 units
LCD Size	8mm
Dimensions	5.04" x 2.24" x 1.18" (128 x 57 x 30 mm)
Weight	7 ounces (200 grams)
Power Supply	3V CR-2450 batteries (2) AC adapter (<i>optional</i>)
Warranty	1 year

* **NOTE:** per ASTM D 2240-05, Sect 9.3: It is accepted that durometer readings below 20 or above 90 are not considered reliable. It is suggested that readings in these ranges be omitted.

4.1 Conformance to International Standards

Model	ASTM D2240	DIN 53505	ISO 868	ISO 7619
DD-100-A	●	●	●	●
DD-100-B	●			
DD-100-C	●			
AD-100-D	●	●	●	●
DD-100-DO	●			
DD-100-O	●			
DD-100-OO	●			

4.2 Dimensional Drawings

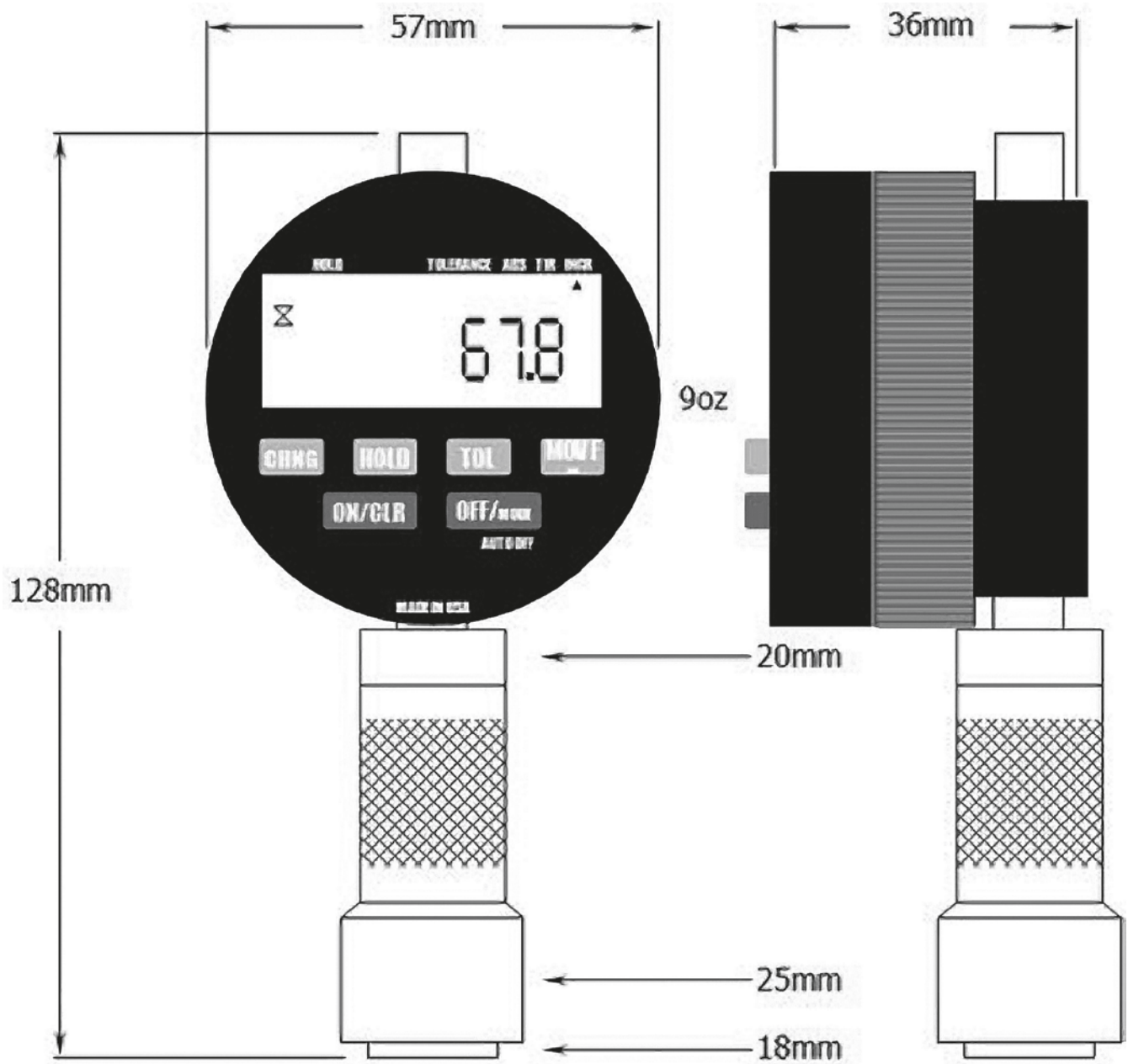

5.0 Calibration and Repair

All Check Line durometers requiring calibration and/or certification should be sent directly to ELECTROMATIC Equipment Co., Inc.

6.0 Warranty

ELECTROMATIC Equipment Co., Inc. (ELECTROMATIC) warrants to the original purchaser that this product is of merchantable quality and confirms in kind and quality with the descriptions and specifications thereof. Product failure or malfunction arising out of any defect in workmanship or material in the product existing at the time of delivery thereof which manifests itself within one year from the sale of such product, shall be remedied by repair or replacement of such product, at ELECTROMATIC's option, except where unauthorized repair, disassembly, tampering, abuse or misapplication has taken place, as determined by ELECTROMATIC. All returns for warranty or non-warranty repairs and/or replacement must be authorized by ELECTROMATIC, in advance, with all repacking and shipping expenses to the address below to be borne by the purchaser.

THE FOREGOING WARRANTY IS IN LIEU OF ALL OTHER WARRANTIES, EXPRESSED OR IMPLIED, INCLUDING BUT NOT LIMITED TO, THE WARRANTY OF MERCHANTABILITY AND FITNESS FOR ANY PARTICULAR PURPOSE OR APPLICATION. ELECTROMATIC SHALL NOT BE RESPONSIBLE NOR LIABLE FOR ANY CONSEQUENTIAL DAMAGE, OF ANY KIND OR NATURE, RESULTING FROM THE USE OF SUPPLIED EQUIPMENT, WHETHER SUCH DAMAGE OCCURS OR IS DISCOVERED BEFORE, UPON OR AFTER REPLACEMENT OR REPAIR, AND WHETHER OR NOT SUCH DAMAGE IS CAUSED BY MANUFACTURER'S OR SUPPLIER'S NEGLIGENCE WITHIN ONE YEAR FROM INVOICE DATE.

Some State jurisdictions or States do not allow the exclusion or limitation of incidental or consequential damages, so the above limitation may not apply to you. The duration of any implied warranty, including, without limitation, fitness for any particular purpose and merchantability with respect to this product, is limited to the duration of the foregoing warranty. Some states do not allow limitations on how long an implied warranty lasts but, notwithstanding, this warranty, in the absence of such limitations, shall extend for one year from the date of invoice.

ELECTROMATIC Equipment Co., Inc.
600 Oakland Ave. Cedarhurst, NY 11516—USA
Tel: 1-800-645-4330/ Tel: 516-295-4300/ Fax: 516-295-4399

Every precaution has been taken in the preparation of this manual. Electromatic Equipment Co., Inc., assumes no responsibility for errors or omissions. Neither is any liability assumed for damages resulting from the use of information contained herein. Any brand or product names mentioned herein are used for identification purposes only, and are trademarks or registered trademarks of their respective holders



Albuquerque Industrial
69-10 108th Street # 2-O
Forest Hills, NY 11375 U.S.A.

www.abqindustrial.net
e-mail: info@abqindustrial.net
Toll Free: +1 (888) 275-5772
Tel: +1 (718) 846-6458
Fax: +1 (718) 846-6459