

# CAP-TA

CAP TORQUE TESTER

## User's Guide





***Thank you!***

Thank you for purchasing a CAP-TA Cap Torque Tester. We are confident that you will get many years of service from this product.

The CAP-TA can be used to test cap torque for a number of different closure shapes and sizes, along with other types of samples. To maintain normal functioning of the tester, avoid repetitive overloads and shock loads.

We hope that this User's Guide will provide a comprehensive explanation of the CAP-TAs operation and sufficient detail on its specifications. However, if you have any other questions or concerns, our technical support and engineering teams will be eager to help you.

Thank you again for your purchase and happy testing!

**TABLE OF CONTENTS**

---

**UNPACKING AND SETTING UP** ..... 2

**LIST OF INCLUDED ITEMS** ..... 2

**CONTROLS** ..... 3

**DISPLAY** ..... 3

**POWER** ..... 4

**SETTING UP THE SAMPLE**..... 4

**CONFIGURATION** ..... 5

**CALIBRATION**..... 6

**OUTPUTS** ..... 7

**SPECIFICATIONS** ..... 8

**DIMENSIONS**..... 9

**WARRANTY** ..... 9

## UNPACKING AND SETTING UP

---

1. Carefully unpack the CAP-TA and check for any damage. Inspect the contents to ensure that you have received a tester complete with all accessories – see “List of included items” below.
2. Place the tester on a firm, flat and level working surface free from vibration. If preferred, the CAP-TA can be secured to a work bench with screws through the four tapped holes in the underside of the base. Then fasten the sample gripping posts into the desired holes on the sliders (see Fig. 1).

## LIST OF INCLUDED ITEMS

---

Quantity	Item
1	CAP-TA Torque Tester
1	User's guide (this booklet)
4	Sample gripping posts
2	Sample gripping jaws (optional, see below)
1	Carrying case (optional)
1	AC adapter
1	Battery
1	Certificate of calibration

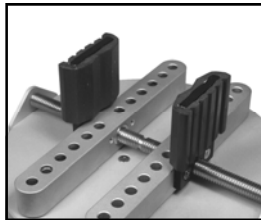

### CT001 flat jaws (optional)

These jaws are designed for use with square or other shaped containers, in addition to round samples. The jaws are reversible; one side has a V-groove, while the other side is flat. These jaws can be mounted to the inside of the sliders, or the outside.

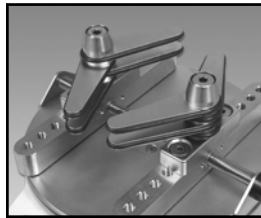

### CT003 adjustable jaws (optional)

These jaws are designed for use with unique shaped samples. The four gripping arms per jaw may be independently repositioned in 45° increments to accommodate unique profiles. Loosen the screw at the top of the jaw to separate the arms and reposition as desired.

## CONTROLS



### POWER / ENTER

Turns power on and off. Also used to select configuration menu items.

### PEAK / ADVANCE

Used to switch between Clockwise Peak, Counterclockwise Peak and Normal (real time) display modes. The actual peak readings are always captured and can be recalled at any time by pressing this button. Also used to step through configuration menu items.

### ZERO

Zeros any tare value (up to the full capacity of the gauge) and clears the peak readings stored in memory.

### DATA

Used to output the torque data point currently displayed.

### UNITS

Changes measurement units between lbin, Ncm, and kgmm.

## DISPLAY

The display consists of a 4 1/2-digit section and several indicators. Their functions are listed below.

<b>LO BAT</b>	Low battery voltage indicator
<b>CW</b>	Clockwise torque indicator
<b>CCW</b>	Counterclockwise torque indicator
<b>CW PEAK</b>	Peak clockwise torque indicator
<b>CCW PEAK</b>	Peak counterclockwise torque indicator
<b>LBIN, NCM, KGMM</b>	Units of measurement
- - - - (dashes)	Overload (>110% of range) Reduce torque immediately

## CAP-TA Cap Torque Testers

---

### POWER

---

The CAP-TA can be operated by the included 9V non-rechargeable battery or by the included AC adapter. Battery life is approximately 30 hours.

***Do not use adapters other than supplied or instrument damage may occur.***

There are three levels of low battery voltage indication. At the first level the display shows a steady "LO BAT" indicating approximately one hour of charge remaining. The second level is indicated by a flashing "LO BAT" indicator. At the third level the whole display except the "LO BAT" indicator will flash for three seconds after which time the instrument will turn itself off. This prevents the instrument from working at voltages too low for reliable operation.

To access the battery, loosen the four screws on the bottom plate.

### SETTING UP THE SAMPLE

---

Place the sample between the posts or jaws of the tester, and tighten, using the knob. Posts can be placed in any of the holes on the sliders (see Figs. 1 & 2 below). Ensure that the sample is gripped firmly, however, excessive tightening of thin-walled closures may result in sample deformation, possibly affecting test results. When the sample is secured, ***gradually*** exert torque by hand. Sudden torque application may produce incorrect readings.

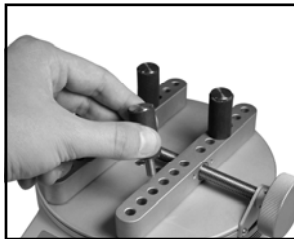

**Fig. 1**  
Posts can easily be moved  
between holes

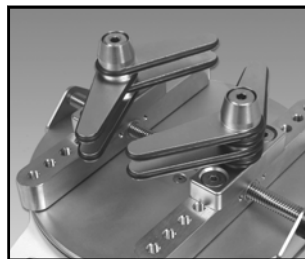
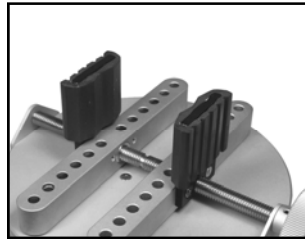

**Fig. 2**  
Optional jaws offer alternative  
gripping methods

## CONFIGURATION

CAP-TA torque testers have several features with programmable options allowing many user-specified choices. To enter the configuration menu, perform the following:

1. Turn off the tester
2. Press and hold PEAK
3. Turn on the tester
4. Release PEAK

The version number of the internal software will be displayed for a short time. The following secondary functions of keys are used during the configuration process:

<b>ENTER</b>	Used to select a menu choice
<b>ADVANCE</b>	Used to step through menu choices

**NOTE:** Once the menu has been entered, it can only be exited if changes have been made.

The following list shows all configuration options. *Italics* indicate factory settings.

### 232 - RS-232 settings sub-menu

232d	Output Disabled
<b>232E</b>	<b>Output Enabled</b>
300	300 baud
600	600 baud
1200	1200 baud
2400	2400 baud
4800	4800 baud
<b>9600</b>	<b>9600 baud</b>
7-1E	7 data bits, 1 stop bit, even parity
7-1o	7 data bits, 1 stop bit, odd parity
7-2E	7 data bits, 2 stop bits, even parity
7-2o	7 data bits, 2 stop bits, odd parity
7-2n	7 data bits, 2 stop bits, no parity
8-1E	8 data bits, 1 stop bit, even parity
8-1o	8 data bits, 1 stop bit, odd parity
<b>8-1n</b>	<b>8 data bits, 1 stop bit, no parity</b>
8-2n	8 data bits, 2 stop bits, no parity
<b>Ft F</b>	<b>Full data (numeric + units)</b>
Ft n	Numeric data only

### bcd - Mitutoyo BCD settings sub-menu

bcd	Output disabled
<b>bcdE</b>	<b>Output enabled</b>
nPOL	No polarity (absolute value)
<b>POL</b>	<b>Data with polarity (+ for CW, - for CCW)</b>

## CAP-TA Cap Torque Testers

---

### AoFF - Automatic shutoff settings sub-menu

no	Disabled
1	1-minute automatic shutoff
<b>5</b>	<b>5-minute "</b> "
10	10-minute " "
20	20-minute " "
30	30-minute " "

### init - Initial (default) settings sub-menu

<b>LBIN</b>	<b>Pound-inch as default unit</b>
KGMM	Kilogram-millimeter as default unit
NCM	Newton-centimeter as default unit
<b>CCW</b>	<b>Real time display at turn on</b>
PEAK CW	Peak clockwise display at turn on
PEAK CCW	Peak counterclockwise display at turn on

**CAL - Calibration sub-menu. See CALIBRATION section.**

## CALIBRATION

---

To properly calibrate the CAP-TA, application of a precise torque value equal to the full capacity of the tester in **pound-inches** (regardless of the displayed units) is required.

While holding PEAK, turn on power to the tester. When 'CAL' appears on the display, press ENTER three times to select the calibration mode. At the 'null' prompt, press ZERO. At the 'SPAN' prompt, apply the calibration torque and press ENTER. The display will show 'uuuu' or 'nnnn' if the calibration torque is insufficient or excessive, respectively. If this happens, the only way to terminate the calibration mode is by momentarily disconnecting the battery or connecting the AC adapter to the tester without plugging the other end into a wall outlet. This will stop the calibration procedure without making any changes to the previous calibration data.

Successful calibration is indicated by 'donE' on the display. Press ENTER to save the changes and resume normal operation.

## OUTPUTS

### RS-232

Data transmission can be initiated by pressing DATA or through an external device by sending ASCII "?". The tester will respond by sending the current reading in either full or numeric format, depending on the configuration setting (see Configuration section). Polarity sign indicates CW (+) or CCW (-) torque. The transmitted string has the following format:

[POLARITY (SPACE OR -)][DATA][SPACE][UNITS (IF ENABLED)][CRLF]

### Mitutoyo BCD

This output is useful for connection to data collectors, printers, multiplexers or any other device capable of accepting Mitutoyo BCD data. The transmission is initiated by pressing DATA or by the receiving device.

### I/O connector pin diagram

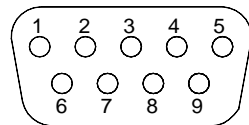

DB-9P

1	RS-232 receive	Input
2	RS-232 transmit	Output
3	Mitutoyo request	Input
4	Mitutoyo clock	Output
5	Signal ground	-
6	No connection	
7	No connection	
8	Mitutoyo ready	Output
9	Mitutoyo data	Output

## CAP-TA Cap Torque Testers

---

### **SPECIFICATIONS**

---

Accuracy:	±0.5% of full scale ±1 digit
Sampling rate:	65/s
Display update rate:	2.5/s in normal mode, 65/s in peak mode
Safe overload:	150% of gauge capacity. Display shows ---- (dashes) above 110%.
Outputs (optional):	
RS-232:	Baud rates between 300 and 9600
Mitutoyo:	Standard Mitutoyo BCD output
Connector:	9-pin D-type male
Power:	9V battery or AC adapter
Battery life:	30 hours of continuous operation
Weight:	6.5 lb [2.9 kg]
Capacity x resolution:	
CAP-TA-12	12 x 0.01 lbFin, 140 x 0.1 kgFmm, 135 x 0.1 Ncm
CAP-TA-50	50 x 0.05 lbFin, 580 x 0.5 kgFmm, 570 x 0.5 Ncm
CAP-TA-100	100 x 0.1 lbFin, 1150 x 1 kgFmm, 1150 x 1 Ncm

**DIMENSIONS**

in [mm]

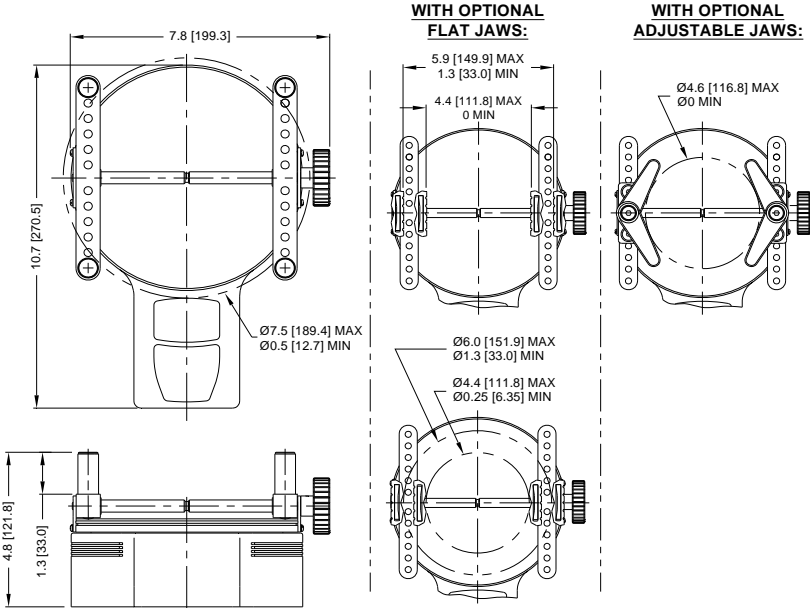

**WARRANTY**

EEC Corporation expressly warrants to its buyer for three (3) years from the date of delivery that the goods sold are free from defects in workmanship and materials. EEC Corporation will, at its option, repair or replace or refund the purchase price of goods found to be defective. This remedy shall be the buyer's sole and exclusive remedy. Any modification, abuse, exposure to corrosive environment or use other than intended will void this warranty. This warranty is in lieu of all other warranties, including implied warranties of merchantability and fitness for an intended purpose. In no event shall EEC Corporation be liable for any incidental and consequential damages in connection with goods sold or any part thereof.



**ELECTROMATIC Equip't Co., Inc**

600 Oakland Ave.

Cedarhurst, NY 11516

Tel: 800-645-4330 / 516-295-4300

Fax: 516-295-4399

Email: [info@checkline.com](mailto:info@checkline.com)

Website: [www.checkline.com](http://www.checkline.com)