

2 YEAR WARRANTY (RESTRICTIONS APPLY)

Imada, Inc. warrants its products to the original purchaser to be free from defects in workmanship and material under normal use and proper maintenance for two years (one year for adapters, attachments and cables) from original purchase. This warranty shall not be effective if the product has been subject to overload, shock load, misuse, negligence, accident or repairs attempted by others than Imada, Inc.

During the warranty period, we will, at our option, either repair or replace defective products. Please call our customer service department for a return authorization number and return the defective product to us with freight prepaid.

The foregoing warranty constitutes the SOLE AND EXCLUSIVE WARRANTY, and we hereby disclaim all other warranties, express, statutory or implied, applicable to the products and/or software, including but not limited to all implied warranties of merchantability, fitness, non-infringement, results, accuracy, security and freedom from computer virus. In no event shall Imada, Inc. and/or its affiliated companies be liable for any incidental, consequential or punitive damages in connection with the use of its products and/or software.

Cap Torque Tester

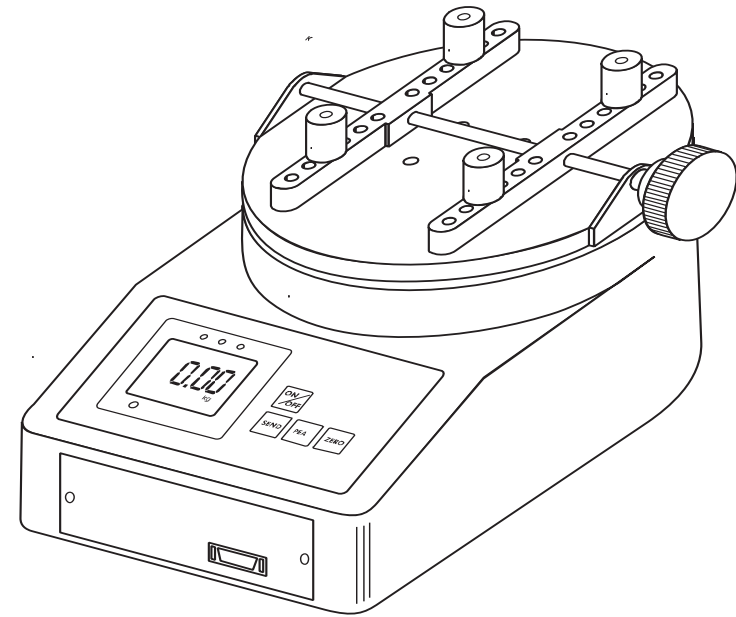

Model DTX2



Albuquerque Industrial
69-10 108th Street # 2-0
Forest Hills, NY 11375 U.S.A.

www.abqindustrial.net
e-mail: info@abqindustrial.net
Toll Free: +1 (888) 275-5772
Tel: +1 (718) 846-6458
Fax: +1 (718) 846-6459

Specifications subject to change without notice.

INSTRUCTION MANUAL

INTRODUCTION

Model DTX2 is a highly sophisticated, cap torque tester which offers programmable high/low setpoints for go/no go testing. Store up to 1,000 values into memory, which can be transmitted using Digimatic or RS-232 formats. Use the Real Time mode to display torque transients, or the Peak mode to capture the peak torque achieved during a test. Select measuring units between lb-in, kg-cm and N-cm.

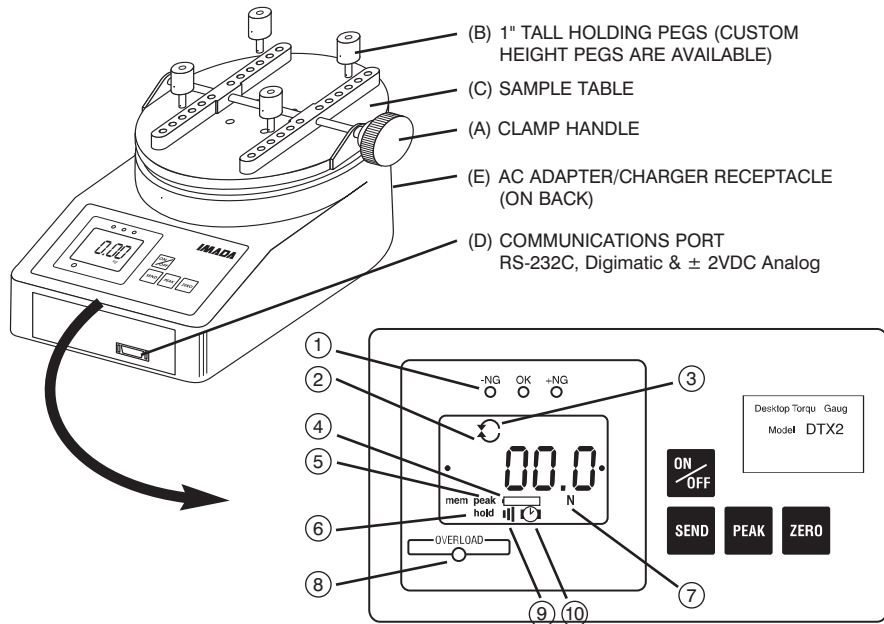

- ① **Programmable Setpoint LED's**
When high-low setpoints are set, LED indicates below (-NG), within (OK), or above set point value (+NG).
- ② **CW icon**
Displayed for CW measurements.
- ③ **CCW icon**
Displayed for CCW measurements.
- ④ **Battery icon**
Flashes when the NI-MH cells need to be charged.
- ⑤ **PEAK icon**
When continuously displayed, peak function is activated.
- ⑥ **HOLD icon**
Displays when external hold signal is activated or SEND button is pressed.
- ⑦ **Torque Units**
Displays selected measuring units. (Lbf-in, kgf-cm and N-cm)
- ⑧ **Overload Indicator**
Flashes at 110% of rated capacity.
- ⑨ **Alarm Icon**
- ⑩ **Auto Power Off icon**

DIMENSIONS

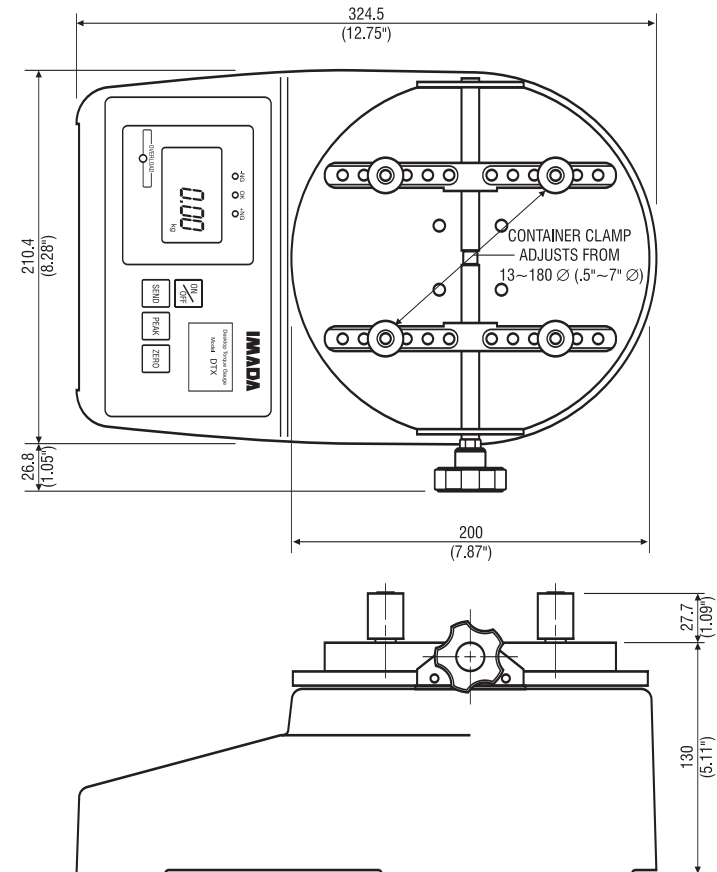

Model	Capacity (Resolution)		
	lbf-in	kgf-cm	N-cm
DTX2-15	15.00 (0.01 lbf-in)	20.00 (0.01 kgf-cm)	200.0 (0.1 N-cm)
DTX2-40	40.00 (0.01 lbf-in)	50.00 (0.01 kgf-cm)	500.0 (0.1 N-cm)
DTX2-85	85.0 (0.1 lbf-in)	100.0 (0.1 kgf-cm)	1000 (1 N-cm)

Imada DTX2 Series Specifications

Accuracy	± 0.5% F.S. ± 1 LSD
Selectable Units	lbf-in, kgf-cm, and N-cm
Overload Capacity	200% of F.S. Overload indicator flashes beyond 110% of F.S.
Power	Rechargeable Ni-MH battery pack or Imada AD120/230 adapter
Battery Indicator	Icon flashes when battery is low
Battery Life	approx. 8 hours (recharge time approx. 10 hours)
Memory	Non-volatile, recall up to 1,000 data
Setpoints	Programmable high/low setpoints with color-coded LED indicators and output signal
Outputs	RS-232C, Digimatic and ± 2 VDC analog output
Auto Power Off	5, 10, 30, 60 minutes or OFF (selectable)
Operating Temp.	32° to 100°F (0° to 40°C)

PRECAUTIONS

DTX2 Cap Torque Tester is a sensitive instrument. The load cell can be damaged regardless of whether the unit is ON or OFF. *Follow these precautions to keep your DTX2 from being damaged.*

1. Do not exceed unit's capacity regardless if power is on or off.
2. Only use the Imada AC adapter/charger, other brands may cause serious damage.
3. Accuracy may be affected if unit is exposed to high humidity, dust or extreme shock.
4. Do not disassemble unit. Disassembly voids warranty.
5. Recommended re-calibration cycle is one (1) year.
6. When operating or moving do not lift or twist the DTX2 table or carry by holding the knob or table.
7. Before shipping, remove the DTX2 table from the base and pack both items together.

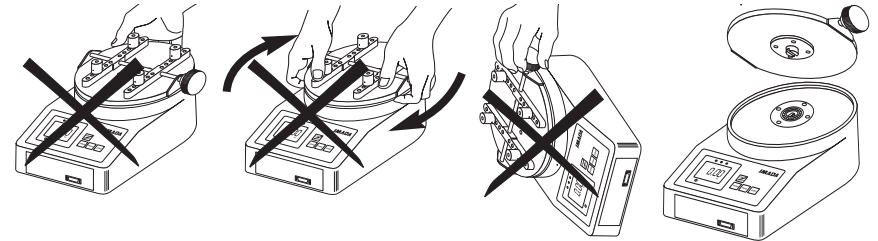

PREPARATION

The sample table (C) must be assembled with the main unit.

1. Connect AC adapter/charger (AD120) to the tester, then plug into 115 VAC outlet (AD230 AC adapter/charger for 230VAC).
Tester can also use internal Ni-MH batteries without plugging into AC power. Turn on the tester and check that the display is at zero and overload indicator is not flashing.

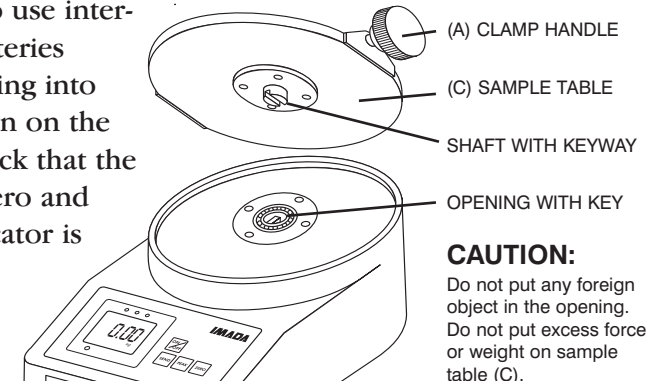

PREPARATION (continued)

2. Hold sample table (C) upright with clamp handle (A) on right.
3. Slowly insert shaft on bottom of sample table (C) into top circular opening of main unit (make sure key and key way line up).
CAUTION do not apply excessive torque when assembling. If unit is overloaded the overload indicator will flash (the tester can be overloaded whether ON or OFF).
4. Choose hole locations for holding pegs based on the size of the container being tested. Make sure the hex portion of the pegs fits into the groove to prevent peg rotation.

NOTE:

Make sure hex portion of the peg fits into the groove to prevent peg rotation.

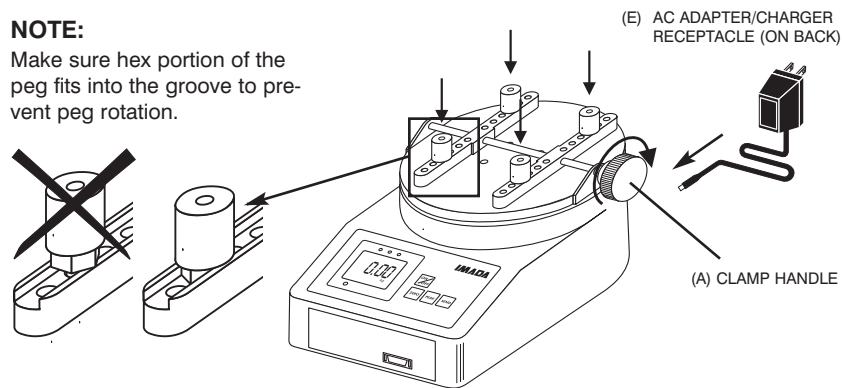

OPERATION

Selecting Units

Press **ON/OFF** to turn on the tester. The LCD display briefly shows the capacity of the tester and then zero with a measuring unit (factory setup is lbf-in). If you want to change to other units:

1. Turn off the tester.
2. Press **ON/OFF** again while holding **ZERO** to enter Power-Off programming mode (CF9 flashes with solid nn0).
3. Press **SEND** to display U-03 with a unit, then press **PEAK** or **ZERO** to cycle desired units (lbf-in, kgf-cm and N-cm), and press **SEND** to select (CF9 flashes with solid End).
4. Press **ON/OFF** to exit 1st. programming mode.

Once units are selected, the tester retains them as a default.

Power-Off programming (clear data from memory)

Turn off the tester. Press **ON/OFF** again while holding **SEND** to enter memory mode.

Memory clear

Memory location and value cycle. Press PEAK or ZERO to increase or decrease memory location (and corresponding value).

Single Memory Clear A memory location with a dot at both ends is the last stored data and the only one that can be erased. Press SEND to erase, ErASed is displayed. If you attempt to erase other locations Error is displayed. Press ON/OFF to exit.

All Memory Clear While a memory value or location is displayed, press SEND for 3 seconds, all data is erased and ErASed is displayed, then -----. Press ON/OFF to exit.

Power-Off programming

Turn off the tester. Press **ON/OFF** again while holding **ZERO** to enter Power-Off programming (CF9 flashes with solid m0). Press **PEAK** or **ZERO** to cycle CF9m0, CF9m1, CF9m2, CF9m3(USB models only) and CF9End. Press **SEND** to select a function.

CF9 m0 Units selection

Press PEAK or ZERO to cycle; 'U-01': kgf-cm, 'U-02': N-cm, 'U-03': lbf-in or ozf-in
Press SEND to select, CF9End displays. Press SEND to exit.

CF9 m1 Torque dampening

Factory set='Fd6'

Press PEAK or ZERO to cycle: 'Fd0, Fd 1, Fd2, Fd3, Fd4, Fd5 or Fd6'. Torque dampening averages rapid torque changes over time. Larger numbers allow more dampening. Press SEND to select, CF9End displays, press SEND to exit (Torque dampening rate displays each time the tester is turned on).

CF9 m2 +/- indicator

Default='SC-OFF'

Press PEAK or ZERO to cycle. 'SC-OFF': CW (+) and CCW (-) or 'SC-On': CW (-) and CCW (+). Press SEND to select, CF9End displays, press SEND to exit.

Note: All power-on and power-off programming functions except for unit selection and display orientation can be reset to factory defaults by the following procedure.

Turn on the tester Press PEAK and ZERO for 3 seconds to display flashing CF9 with solid F0. Press ZERO and PEAK for 5 seconds until flashing CF9 disappears and becomes only solid F0. Then release both PEAK and ZERO. Tester goes back to measuring mode with factory default settings.

Power-On programming

Turn on the tester. Press **PEAK** and **ZERO** for 3 seconds to enter Power-On programming (CF9 flashes with solid F0). Press **PEAK** or **ZERO** to cycle CF9 F0, CF9 F1, CF9 F2, CF9 F3, CF9 F4, CF9 F5, CF9 F6 and CF9 End. Press **SEND** to select a function.

CF9 F0	Memory recall	
Press SEND, memory location and value cycle. Press PEAK or ZERO to increase or decrease memory number (and corresponding value). Press SEND to exit.		
CF9 F1	High & low setpoints	Default='0' both Hi and Lo
Press SEND, -HI- displays, then the high set value (i.e. H 10.0). Press PEAK to increase and ZERO to decrease, press SEND to select. -LO- displays then the low set value (i.e. L 5.0). Press PEAK to increase and ZERO to decrease, press SEND to select, CF9 End displays. Press SEND again to exit.		
CF9 F2	Peak mode	Default='Or'
Press SEND, 'Or' or 'And' displays. Press PEAK or ZERO to cycle. Press SEND to select. 'Or Peak' records the Peak in either CW or CCW during test. 'And Peak' records both the CW peak and CCW peak during a test.		
	Zero reset memory store	Default='AA-OFF'
Auto memory displays after Peak mode is selected. 'AA-On' enables automatic memory storage and reset to zero. 'AA-OFF' turns off auto function. Press PEAK or ZERO to change. Press SEND to select, CF9End displays, press SEND again to exit.		
CF9 F3	Auto zero reset	Default='Ac-OFF'
Press SEND, 'Ac-On' or 'Ac-OFF' displays. Press PEAK or ZERO to cycle. If 'Ac-On' is selected, auto zero reset duration can be programmed. Press PEAK to increase or ZERO to decrease. Press SEND to select, CF9End displays, press SEND again to exit (i.e. 'SEC 3.0' is displayed for auto zero reset duration of 3 seconds).		
CF9 F4	Audible beep	Default='Sd-On'
Press SEND, 'Sd-On' for alarm on, or 'SD-OFF' for off displays. Press PEAK or ZERO to cycle. Press SEND to select. CF9End displays, press SEND again to exit (alarm sounds for values over HI or under LO setpoints).		
	Setpoint alarm	Default=''
Setpoint alarm displays after audible beep is selected. 'AL-On' for setpoint alarm on or 'AL-OFF' for off. Press PEAK or ZERO to cycle. Press SEND to select, CF9End displays, press SEND again to exit.		
CF9 F5	Reverse display	
Press SEND, '-12345' for standard or 'ᄀᄁᄂᄃᄄ' for reverse displays. Press PEAK or ZERO to cycle. Press SEND to select. Flashing CF9 with solid End displays. Press SEND again to exit. (for vertical mounting).		
CF9 F6	Auto power off duration	Default='AO-10'
Press SEND, 'AO-10' displays. Press PEAK or ZERO to cycle 'AO-5' for 5 min auto power off duration, 'AO-10' for 10 min, 'AO-30' for 30 min, 'AO-60' for 60 min and 'AO-OFF' to by-pass auto power off. Press SEND to select, CF9End displays, press SEND again to exit.		

Programming Setpoints (optional)

Program High and Low setpoints for easy GO/NO GO testing.

1. Turn on the tester
2. Press **PEAK** and **ZERO** for 3 seconds to enter Power-On programming mode (CF9 flashes with solid F0).
3. Press **PEAK** to display flashing CF9 with solid F1, then press **SEND** to display -HI- and then the high set value (i.e. H 10.0).
4. Press **PEAK** to increase and **ZERO** to decrease the High set value, then press **SEND** to display -LO- and then low set value (i.e. L 5.0). Press **PEAK** to increase and **ZERO** to decrease the Low set value and press **SEND** to display flashing CF9 with solid End.
5. Press **SEND** again to exit Power-On programming mode.



HI 10.0

HIGH SETPOINT

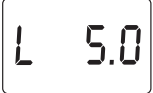

L 5.0

LOW SETPOINT

Peak or Real time Measuring Mode

Press **ON/OFF** to turn on and the tester automatically enters real time measuring mode. For peak measurement press **PEAK**. The "Peak icon" appears on the display. Peak readings will not change until a higher value is measured. Press **PEAK** again to return to real time mode.



0.0

REAL TIME MODE DISPLAY



0.0

PEAK MODE DISPLAY

"Or PEAK" is the factory default which measures peak CW torque or peak CCW torque. "And PEAK" measures both peak CW torque and peak CCW torque during a test. Refer to the F2 function of the Power-On programming table for the "And PEAK" function.

Tare

Clamp container firmly to the sample table (C) by tightening the clamp handle (A). If necessary, press **ZERO** to tare before the test.

Pressing **ZERO** also clears the peak reading.

Grip the sample lid and rotate to open (CCW) or close (CW). The display will indicate the torque value with CCW ↺ or CW ↻ icons.

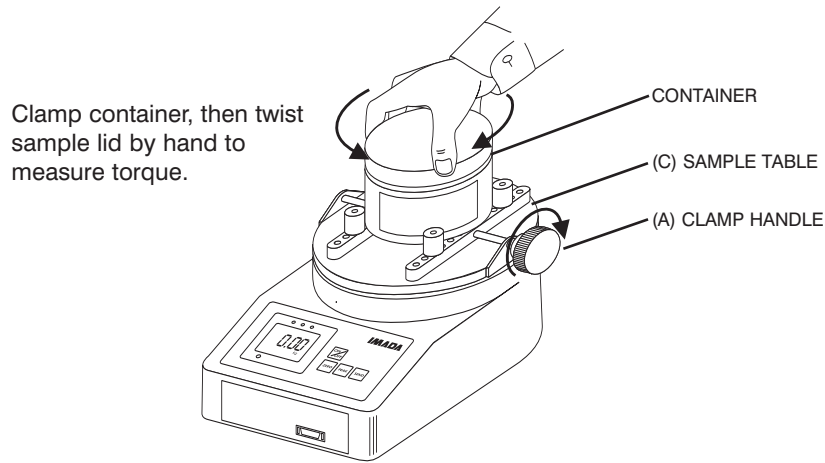

If High and Low setpoints have been programmed (see page 5), for example, 5 lbf-in is set as Low and 10 lbf-in as High, the ORANGE LED light for measurements less than 5 lbf-in (Low setpoint). GREEN lights between 5–10 lbf-in and RED lights over 10 lbf-in (High setpoint). Setpoint output is available through the Communications port (see page 7).

After measuring, press the **SEND** button to transmit data to:

RS-232 models: RS-232C or Digimatic devices

Storing Data into Memory

During measurement whether Peak or Real Time, press **SEND** to store and display up to 1,000 torque values into memory. (If no data is stored ----- is displayed then flashing CF9 with solid End).

RECHARGING NI-MH BATTERY

1. To maximize the life of the battery, power is automatically shut off after 10 minutes of non-use or user-defined interval. Automatic shut off is bypassed during USB output or when used with the AC adapter/charger.

2. Battery icon will flash when the tester needs to be recharged.

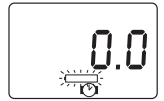

3. Push **ON/OFF** to turn off power. Only use the IMADA AC adapter/charger provided, AD120 for 115VAC, AD230 for 230VAC. Plug into the correct AC output. It takes 10 hours to charge fully.

4. When the tester is turned off, make sure the AC adapter/charger is disconnected to avoid overcharging.

OPTIONAL CABLES



10' Analog cable
CB-104

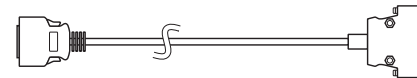

10' RS-232C cable, 9 pin female
CB-204

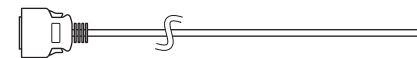

10' Digimatic Cable
CB-304

2. Mitutoyo Digimatic Signal

Connect the CB-304 cable to the communications port and the device receiving the data. Set up parameters as instructed from the Mitutoyo processor manual.

3. ± 2 VDC Analog Signal

Connect the CB-104 analog cable to the communications port and the device receiving the data.

4. External Switch Display Freeze

By connecting #10 and #12 of the communications port, the tester instantaneously captures the critical reading and holds the display from remote locations (use contact closure and **DO NOT** apply voltage across #10 and #12).

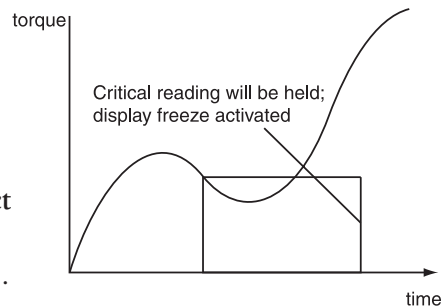

- (1) Pay extra attention to avoid overload as display value will not change during display hold.
- (2) Use contact closure only and **DO NOT** apply voltage across #10 and #12 port pins.

5. External Switch Display Clear

By connecting #8 and #12 of the communications port, display can be cleared from remote locations (use contact closure and **DO NOT** apply voltage across).



Use contact closure only and **DO NOT** apply voltage across #8 and #12 port pins.

Recalling Data from Memory

1. Turn on the tester.
2. Press **PEAK** and **ZERO** for 3 seconds to enter Power-On programming (CF9 flashes with solid F0). Press **SEND** and the display cycles memory location and value. Press **PEAK** to increase location and **ZERO** to decrease. Press **SEND** to exit.

Clearing Data from Memory

1. Turn off the tester.
2. Press **ON/OFF** again while holding **SEND** to enter memory mode.

Single Memory Clear

A memory location with a dot at both ends is the last stored value and the only one that can be erased. Press **SEND** to erase and ErASEd is displayed. If you erase any other location Error is displayed.

All Memory Clear

While a memory location or value is displayed, press **SEND** for 3 seconds, all data is erased, ErASEd is displayed, then - - - - and flashing CF9 with solid End. Press **ON/OFF** to exit. (See page 14-15).

Downloading Data from Memory

Choose between the following download methods.

Digimatic Data Download from Memory

1. Connect the tester and device receiving data with CB-304 cable.
2. Turn on the tester. Press **PEAK** and **ZERO** for 3 seconds to enter Power-On programming (CF9 flashes with solid F0).
3. Press **SEND** to transmit all data.
4. Press **SEND** again to exit.

RS-232C Data Download from Memory

Connect the tester and device receiving data with a CB-204 cable. Use the I[CR] ASCII command to transmit data (uppercase ASCII character format).

COMMUNICATIONS PORT

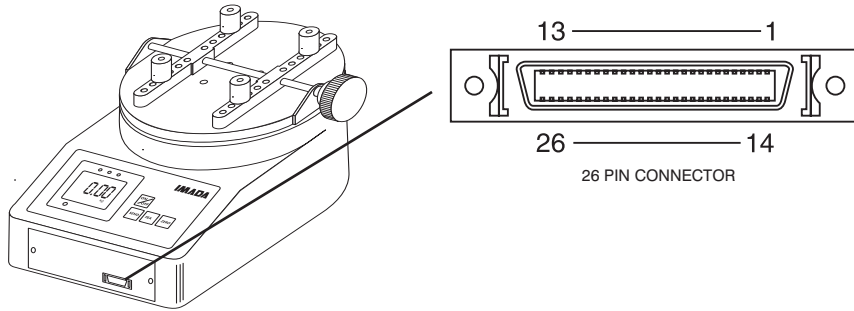

COMMUNICATIONS PORT PIN DEFINITIONS

PIN#	DEFINITION	
1	RS-232C Signal Output	RS-232C Output
2	RS-232C Receive Signal	
3	RS-232C Ground	
4	Analog Output ± 2 VDC	Analog Output
5	Analog Ground	
6		External Inputs
7		
8	External Switch Display Clear	
9	External Switch for Peak/Real Time Modes	
10	External Switch Display Freeze	
11		
12	Ground	
13	Ground	
14		
15		
16	Digimatic Data Request	Digimatic Output
17	Digimatic Data Ready	
18	Digimatic Data Clock	
19	Digimatic Data Signal Out	
20	Digimatic Data Ground	
21	+NG Output	
22	OK Output	
23	-NG Output	
24	Overload Output	
25	Common	
26	Common	

1. RS-232C bi-directional interface functions

All functions can be duplicated remotely by using the RS-232C interface. Commands must be sent in uppercase ASCII character format followed by a carriage return [CR].

RS-232C Signal: 8 data, 1 stop, no parity. Baud Rate: 19200 bps

RS-232C INTERFACE FUNCTIONS (Upper case ASCII format)

COMMAND	FUNCTION	RESPONSE*
T [CR]	Select real time mode	R[CR]
P [CR]	Select peak mode If OR peak is programmed P [CR] = peak If AND peak is programmed P [CR] (1st time)= +peak P [CR] (2nd time)= - peak	R[CR]
Z [CR]	Tare Display	R[CR]
D [CR]	Transmit display data	[direction][value][units][mode] [go/nogo/overload][CR] [direction] +=CW - =CCW [value] 4 digits w/decimal [units] K, N, or O [mode] T=real time value P=peak value H=Hold value M=Memory value [go/nogo] H=+NG O=OK L=-NG E=Overload
V [CR]	Transmit Peak data	P+[value][units][CR] P-[value][units][CR]
g [CR]	Continuous data output (10 data/sec)	
Y [CR]	Stop continuous data output	
K [CR]	Select "kgf-cm" units	R[CR]
N [CR]	Select "N-cm" units	R[CR]
O [CR]	Select "lbf-in" units	R[CR]
B [CR]	Delete last data stored in memory	R[CR]
M [CR]	Store data	R[CR]
I [CR]	Recall memory data	Data format is the same as D command response. It will output END[CR] at the end of data
C [CR]	Clear memory	R[CR]
EXXXYYYY [CR]	Set high/low setpoints(4 digit) XXXX=High, YYYY=Low	R[CR]
E [CR]	Read high/low	EXXXYYYY[CR] setpoint values (4 digit) XXXX=High, YYYY=Low

*Note: E[CR] response if the command is not accepted.